

PIONEERS OF ROCKET TECHNOLOGY

SELECTED WORKS

T. M. Mel'kumov, Editor in Chief

Translation of "Pionery raketnoy tekhniki - Kibal'chich, Tsiolkovskiy, Tsander, Kondratyuk - Izbrannyye trudy." Izdatel'stvo "Nauka," Moscow, 1964.

FACILITY FORM 602

N 66-12164 N 66-12167

(ACCESSION NUMBER)	(THRU)
165	1
(PAGES)	(CODE)
30	30
(NASA CR OR TMX OR AD NUMBER)	(CATEGORY)

GPO PRICE \$ _____

CFSTI PRICE(S) \$ _____

Hard copy (HC) 5.00

Microfiche (MF) 1.00

ff 653 July 65

NATIONAL AERONAUTICS AND SPACE ADMINISTRATION
 WASHINGTON, D.C. NOVEMBER 1965

PIONEERS OF ROCKET TECHNOLOGY
SELECTED WORKS

Editor in Chief:
T. M. Mel'kumov

Editor-Compilers:
B. N. Vorob'yev and V. N. Sokol'skiy

Academy of Sciences of the USSR
Institute for the History of Natural Science and Technology

Translation of "Pionery raketnoy tekhniki - Kibal'chich,
Tsiolkovskiy, Tsander, Kondratyuk - Izbrannyye trudy."
Izdatel'stvo "Nauka," Moscow, 1964, pp. 1-20; 501-669.

ABSTRACT

The present collection contains selected representative writings of two of the earliest thinkers on rocketry in pre-revolutionary Russia and the Soviet Union, an editorial preface, a historical outline of pioneer rocket technology, relevant commentaries, and a complete bibliography, all extracted and translated from the larger work of the same title.

The two authors whose works have been selected, N. I. Kibal'chich ("Concept for an Aeronautical Machine") and Yu. V. Kondratyuk ("To Whomsoever will Read in Order to Build"; "Conquest of Interplanetary Space"), are distinct in that they are men essentially without formal education, least of all in rocketry. The former wrote his "concept" in the last days of his life before being executed, in 1881, for complicity in the assassination of Tsar Alexander II. The second author resided in the remote farming region of Novosibirsk, writing his work while employed in menial labor.

The editorial preface sets the stage by contrasting the concepts of the early pioneers of rocket technology with the most recent advances in this field, notably the impressive feats of the Soviet cosmonauts.

The historical outline completes the picture by presenting a grand sweep from the sheer fantasies of Cyrano de Bergerac in the seventeenth century to the beginning of the World War II, i.e., at which time rocket technology came into its own and gained universal recognition, rather than the attention of science fiction writers and a small handful of gifted visionaries.

It is stressed that the reader should bear in mind, in light of the present state-of-the-art, that the contents of this collection contain a few ideas that are now known to be erroneous, a manner of looking at phenomena that is archaic or even quaint, and a certain phraseology that comes through even in translation; however, the great bulk of the material should be recognized as basically sound and instructive. Again in light of modern-day knowledge, the works of the authors included herein admirably display their insight and foresight.

"...Socialism is the trustworthy launching pad 3*
from which the Soviet Union triumphantly sends
its powerful and highly perfected spaceships
into the Cosmos."

- Pravda, 16 August 1962

EDITOR'S PREFACE

In our time, science and technology have garnered major achievements in the conquest of outer space. These achievements, however, have not been a matter of chance or contrary to expectation. They have been fostered by the efforts of scores of scientists, design engineers, and inventors.

In World War II, the Katyusha, or Soviet truck-launched gunpowder-type tactical missile, was used; the Germans bombarded London with A-4 ballistic rockets, better known as the V-2, with a maximum range of about 350 km at a launch weight of 13 metric tons. In the prewar and early war years, the first flights were made with liquid-propellant rocket engines.

An analysis of the advances in rocketry reveals the truly impressive potential of rockets. This was brilliantly demonstrated soon after the war, when in the Soviet Union, beginning in 1949, and in other countries, exploratory and meteorological rockets, outfitted with the necessary equipment assemblies, were launched in order to study the composition, density, and temperature of the upper strata of the atmosphere. Special capsules were used on Soviet rockets to carry dogs, which were returned to earth in special parachute-equipped devices. It became clear that rockets could be used extensively not only for military purposes but, what was especially significant, in the interest of learning more about the universe beyond earth and for flight to other planets in the solar system. It was on the latter aspect that the Soviet nation focused 4 its attention. A serious and well-planned program was begun to build the complex equipment assemblies required for the exploration of outer space.

The day of 4 October 1957 is recognized as an outstanding event; in the Soviet Union, for the first time in the history of the world, an artificial earth satellite ("sputnik") was successfully put into orbit. On this day began the systematic investigation of the outer void surrounding earth by the launching of new artificial earth satellites. One after another, new frontiers were crossed. The first artificial solar planet was created; the Soviet flag was planted on the moon; an automatic interplanetary space station photographed and transmitted to earth pictures of the unseen side of the moon; an automatic interplanetary space station was launched in the direction of Venus; finally, a series of spaceship launchings was organized with representatives of the animal and plant world, which were returned to earth in a predesignated region. These investigations, carried out in the Soviet Union, provided much valuable information for science and paved the way for the ascent of men into outer space.

A new era in the life of mankind began on 12 April 1961. On this day, the Soviet spaceship Vostok, weighing 4725 kg, carried the world's first cosmonaut, Yu. A. Gagarin, into the historical orbital flight from which, after one orbit,

*Numbers in the margin indicate pagination in the original foreign text.

he was brought down in good condition in a predetermined area. On 6 and 7 August 1961, G. S. Titov made a prolonged space flight. On board the Vostok-2, weighing 4731 kg, he completed 17 orbits around the earth in 25 hours, traveling more than 700 thousand kilometers, i.e., the distance to the moon and back again.

On 11 August 1962, the new, multiton Soviet spaceship Vostok-3 went into orbit with cosmonaut A. G. Nikolayev. One day later, on 12 August, another Soviet space vehicle, the Vostok-4, carried cosmonaut P. R. Popovich into space, where it executed a calculated orbit near that of the Vostok-3 and, after coming into the vicinity of the latter, continued in coordinated flight. For the first time, two cosmonauts were in space at the same time, traveling side by side, maintaining radio communications with earth as well as with each other. This joint space effort, organized with a precision that staggered the imagination, lasted for about 71 hours. The Vostok-3 was in orbit for 95 hours; during this period, cosmonaut Nikolayev completed 64 orbits about the earth, covering a distance of more than 2.6 million kilometers. The Vostok-4 was in orbit for 71 hours, completing 48 orbits and traveling about two million kilometers.

About one year later a new joint flight was made by Soviet cosmonauts. On June 14, 1963, the space satellite Vostok-5 began its flight with cosmonaut V. F. Bykovskiy, and two days later, on 16 June, the satellite Vostok-6 went into orbit around the earth, carrying the world's first woman cosmonaut, V. V. Tereshkova. /5

The flight of V. F. Bykovskiy lasted for 119 hours. During this time, he made 95 orbits about the earth, covering a distance of more than 3.3 million kilometers. The vehicle Vostok-6 was in orbit for 71 hours. During this time, V. V. Tereshkova executed 48 orbits about the earth, traveling about two million kilometers.

The entire world was becoming aware of the high reliability of Soviet rocket systems used to propel spaceships, the enormous power of the rocket powerplants, the high perfection of the vehicles themselves, both in the engineering and in the biological sense. During the entire period that the Soviet cosmonauts were in the state of weightlessness, the conditions for their life activity were maintained completely normal. The ground conditioning of the cosmonauts in special equipment and their physical and moral strengthening confirmed the correctness of the methods used by the medical experts and biologists to prepare the cosmonauts for protracted space flight. During flight, the cosmonauts left their seats, recorded the instrument readings, took motion pictures of the earth and moon.

The problem of sending cosmonauts into moon orbit, to the surface of the moon, and to the nearest planets became the order of the day.

On 12 February 1961, an **automatic** interplanetary space station was sent to Venus, another on 1 November 1962 into the vicinity of Mars.

After the Soviet Union, the United States became **engaged** in the exploration of outer space; they launched a large number of artificial earth satellites with

a variety of purposes; in February 1962 a vehicle was sent into orbit as part of the Mercury program, carrying astronaut John Glenn. Subsequently, four more vehicles were fired with astronauts on board into earth orbit, the longest of which was the last one with astronaut Cooper on board (22 orbits, lasting 34 hours). In 1962, the automatic interplanetary vehicle Mariner-2 was launched toward Venus.

The interest in rocket systems and space vehicles has grown in universal and extraordinary proportion. Man has set his sights on distant worlds, fully assured of the realizability of his most daring dreams. It is only natural that there should be an awakening of interest in the history of the origins of the first ideas in the theory of space flight and space vehicles. More and more attention is being drawn to the names of our eminent countrymen: Constantine Eduardovich Tsiolkovskiy (1857-1935), Fridrikh Arturovich Tsander (1887-1933), Yuriy Vasil'yevich Kondratyuk (1897-1942). Another that must be added to these great names of our Russian pioneers in the theory of space flight is the name of the Russian revolutionist Nikolay Ivanovich Kibal'chich (born 1853), who was executed in 1881 for his participation in the assassination of Alexander II and, on the day prior to his death, set down in writing the concept for a rocket-driven flying machine. The manuscript of N. I. Kibal'chich was not found until 1917, after the victory of the revolution in Russia; it begins the present collection. 16

The Soviet people are proud, not only because their country was the first to attain the impressive goal of launching artificial satellites, interplanetary space stations, and the Vostok space vehicles, but also because the first theoretical fundamentals of interplanetary flight were laid down by K. E. Tsiolkovskiy at a time when man was still only thinking about the possibility of aircraft flight. The first work of K. E. Tsiolkovskiy was published in 1903 in the journal Nauchnoye Obozreniye (Scientific Review), No. 5, under the title "The Investigation of Cosmic Space by Reactive Devices (Issledovaniye mirovykh prostranstv reaktivnymi priborami)"; the research on which this work was based was initiated in 1896.

In 1911 and 1912, a new paper by K. E. Tsiolkovskiy was published in the journal Vestnik Vozdukhoplavaniya (Aeronautics Bulletin), Nos. 19 to 22 and 2 to 9, representing a continuation of his original work. These papers contain many original and bold concepts, as well as some of the first analytical equations needed in order to comprehend the role of the principal factors affecting the flight of a space vehicle.

K. E. Tsiolkovskiy derived a formula relating maximum vehicle velocity to the gas exit velocity from the rocket engine and to the propellant-to-rocket mass ratio. He concentrated on the need for finding effective rocket fuels and proposed that, instead of gunpowder rockets, liquid-propellant engines be used with liquid oxygen as the oxidizer and liquid hydrogen or petroleum and its fractions as the fuel. Tsiolkovskiy suggested using one of the components of the liquid propellant for cooling of the engine, the entire system of which contains combustion products at high temperatures. To control the flight of the rocket in empty airless space, Tsiolkovskiy proposed placing rudders in the gas stream issuing from the nozzle; this concept was first put into practice in the

German V-2 rocket. Thinking constantly in terms of interplanetary journeys, Tsiolkolskiy pointed out the suitability of setting up interplanetary space stations in earth orbits. He foresaw the enormous part that artificial earth satellites would have in astronomy.

It is not our intent in this preface to present the reader with a summary of Tsiolkolskiy's many fertile notions in the area of rocket technology and space flight; these can be found by referring directly to the scientist's works. Certain notions of K. E. Tsiolkovski and his philosophical predictions as to the future of mankind are today recognized as incorrect. It should be remembered, however, that his main works were carried out in the prerevolu- 17
tionary era, when the arsenal of science was considerably more meager than it is today. This does not, of course, lessen the outstanding conceptual ground-work laid down by Tsiolkolskiy in rocket design and astronautics.

F. A. Tsander is one of the great innovators and enthusiastic advocates for the development of interplanetary flight projects. He began publishing his works in 1924. In the theoretical respect, he delved more deeply than others into the problems of interplanetary flight and rocket propulsion; furthermore, a highly educated engineer, he worked out some of the design problems, both in propulsion systems and in rockets. Tsander conducted special experiments on models of air-jet and rocket engines. Understanding the need for ensuring life-support conditions in prolonged interplanetary voyages, he methodically pursued research even on the growth of vegetation, the orange tree in particular, using charcoal instead of soil as the nutritive medium.

Of all the original concepts advanced by F. A. Tsander, we note an internal combustion engine driven by liquid oxygen and gasoline, hence not requiring an atmospheric environment; the utilization of metal structural elements no longer needed for continued flight by burning them up in the rocket engine; gliding descent of the spaceship into the atmosphere with cooling of the structure by the irradiation of heat into the external medium; thermal protection of the vehicle on reentry into the atmosphere; and many others. Tsander carried out theoretical calculations to determine the efficiency of rocket engines of various designs, including air-jets and those operating on a combination principle. He was concerned with calculating the trajectories of interplanetary flights and many other problems.

A name less well known in broad segments of society is Yu. V. Kondratyuk. His analytical methods differed from those of K. E. Tsiolkovski. In his manuscript, "To Whomsoever Will Read in Order to Build (Tem, kto budet chitat', chtoby stroit')," presumably written in 1918 and 1919 and included in the present collection, many far-reaching ideas were expressed. In particular, Kondratyuk writes of the possible utilization of the emission of material particles (such as alpha-particles) to propel space rockets, of the "biaxial astatic gyroscope" for maneuvering in flight, of a checkerboard arrangement of fuel and oxidizer nozzles, an arrangement that is used today in liquid-propellant engines. He outlined the principle for a simple integrator for calculating the velocity of the vehicle or the amounts of spent and remaining propellant. An intriguing idea is contained in safeguarding the return of a vehicle to earth by cooling the equipment or using expendable (ejected) outer layers with a heat insulation construction, as well as the concept of utilizing solar energy wherever large 18

accelerations are not required in interplanetary flight, by transforming heat into electrical energy and with the emission of "cathode rays." Like Tsiolkovskiy, Kondratyuk indicated the need for establishing intermediate bases for prolonged interplanetary flights, including a base on the moon.

We must, however, focus attention on the note in the Commentaries, that there is no basis for asserting with complete reliability that these ideas can be traced to 1918-1919; nor do we have complete assurance that all of the notions expressed in the article are the author's original ideas, especially since this manuscript was not published by Kondratyuk during his lifetime.

An expanded and considerably reworked version of Kondratyuk's manuscript was first published in 1929 under the title "Conquest of Interplanetary Space (Zavoyevaniye mezhplanetnykh prostranstv)." This work is also included in the present collection.

Today, in the light of the prominent Soviet advances in the conquest of outer space, the attentive reader can imagine the striking intrepidity of thought that must have been possessed by K. E. Tsiolkovskiy, F. A. Tsander, and Yu. V. Kondratyuk, at a time when men were still thinking about flight in airplanes and, essentially, when they were just beginning to fly in them, to delve so far into fantasy and, most important, to support these fantasies with the first cornerstones of a scientific and engineering foundation. In reading these works, we are tolerant of the isolated erroneous or inaccurate notion and concede with admiration and respect the inestimable contribution that they have made to rocket technology and the space sciences.

It is entirely symptomatic that the first to understand and lend support to the pioneers of rocket technology and space science was V. I. Lenin. In the first years of the Soviet regime, in the face of the enormous difficulties and adversity of postwar devastation, civil war, and hunger, Vladimir Il'ich, working strenuously to solve a tremendous number of major problems, exhibited interest in the idea of interplanetary communications. He gave moral support to the efforts of F. A. Tsander. In 1921, the Council of People's Commissars of the RSFSR, "in recognition of the singular services of a scientific inventor and aviation specialist," granted K. E. Tsiolkovskiy a lifetime pension, which freed him from everyday tasks and permitted complete devotion to solving problems in rocketry and astronautics. It was in the initial years of the Soviet regime that the groundwork was laid for victorious socialism to erect the towering edifice of Soviet rocket science and technology.

The work of K. E. Tsiolkovskiy, F. A. Tsander, and Yu. V. Kondratyuk was continued by talented scientists and designers, theoreticians and engineers, /9 whose energy and efforts have today made possible the results that have so glorified our fatherland. The Soviet government was farsighted in planning a program for creative collectives of rocket experts and giving them comprehensive support. In our own time, the Central Committee of the Communist Party of the Soviet Union, as in V. I. Lenin's time, have had a decisive influence on the successful progress of work on the part of outstanding theoreticians and designers in rocket technology and astronautics. The Soviet nation, in building a communist society, is primarily concerned with charting new routes into space, relying on a powerful industry and on Soviet science and technology, which have attained the highest level of development.

On 1 May 1933, while listening on the radio to the Mayday workers' demonstrations, K. E. Tsiolkovskiy stated these prophetic words: "For forty years I have worked on the reactive engine and have felt that the journey to Mars would not begin for many hundreds of years. But times are changing. I believe that many of you will be witnesses to the first voyage beyond the atmosphere." This belief was based on his conviction that the Bolshevik party and Soviet government were the true leaders of progress in the culture of mankind.

Today, when the notions of conquering space are being carried out successfully, we cannot but respect those representatives of the first generation of rocket experts, the scientists and inventors who gave us the sources of the concepts for interplanetary flight.

The present collection includes the groundlaying works of Russian scientists, the pioneers of rocket technology and astronautics, written in the period from the eighties of the last century to the thirties in this century. The collection in a single volume of the most important articles by Russian scientists on the problems of rocket technology and interplanetary communication is an undertaking of unquestionable interest. A number of papers have become bibliographic rarities. The papers of certain individual authors have been published in isolation from other works.

Almost all of the works included in the present collection (with the exception of the article by Yu. V. Kondratyuk, "To Whomsoever Will Read in Order to Build") have been published more than once. However, when such is the case, the editors have often interjected additions and corrections in the text. In the present edition, the papers are printed in the form in which they were published during the authors' lifetimes or in which they were found in the original manuscripts, preserving the terminology and all stylistic features of the authors. Only the orthography, format dimensions, and generally recognized abbreviations have been necessarily modernized, and obvious typographical errors have been corrected. Editorial insertions are given in brackets.

Occasional unclear, erroneous, or debatable statements, as well as terminology deviating from present-day conventions are discussed in the commentaries at the end of each article. Also given in the commentaries are the most recent additions, changes, and corrections introduced by the scientists in the author's proofs or manuscripts. The commentaries were written with recognition for the comments made by editors of earlier editions of the scientists' works.

The text of the papers published in the present collection is based on the following sources:

Kibal'chich, N. I. A Concept for an Aeronautical Machine (Proyekt vozdukhoplavatel'nogo pribora). Manuscript. Central State Archives of the October Revolution (TsGAOR), F. D. P., Third Business Correspondence, 1881, Report 79, Part I, Supplement, Sheets 1-5.

Tsiolkovskiy, K. E. The Investigation of Cosmic Space by Reactive Devices (Issledovaniye mirovykh prostranstv reaktivnymi priborami). Nauchnoye Obozreniye, No. 5, 1903.

The Investigation of Cosmic Space by Reactive Devices. Vestnik Vozdukhoplavaniya, Nos. 19-22, 1911; Nos. 2, 3, 5-7, 9, 1912.

The Investigation of Cosmic Space by Reactive Devices (supplement to parts I and II of the work by the same name). Special Publication. Kaluga, 1914.

The Spaceship (Kosmicheskii korabl'). Archives of the Academy of Sciences of the USSR, Folio 555, Catalog I, Report 46.

The Investigation of Cosmic Space by Reactive Devices. Special Publication. Kaluga, 1926.

Space Rocket Journeys (Kosmicheskiye raketnyye poyezda). Special Publication. Kaluga, 1929.

Maximum Rocket Velocity (Naibol'shaya skorost' rakety). Archives of the Academy of Sciences of the USSR, Folio 555, Catalog I, Report 105.

Tsander, F. A. Voyages to Other Planets (Perelety na drugiye planety). Tekhnika i Zhizn', No. 13, 1924.

Voyages to Other Planets (second article). Manuscript. F. A. Tsander Family Archives.

Description of the Interplanetary Spaceship System of F. A. Tsander. Manuscript. F. A. Tsander Family Archives.

Voyages to Other Planets (Theory of Interplanetary Travel). Manuscript. F. A. Tsander Family Archives.

Thermal Calculations for a Liquid-Propellant Rocket Engine (Teplovoy raschet raketnogo dvigatelya na zhidkom toplive). Raketnaya Tekhnika, No. 1, Moscow-Leningrad, 1936.

Thermal Calculations for a Liquid-Propellant Rocket Engine (second article). Raketnaya Tekhnika, No. 5, Moscow-Leningrad, 1937.

The Problem of Flight by Means of Reactive Machines (Problema poleta pri-pomoshchi reaktivnykh apparatov). Special Publication. Moscow, 1932.

Reactive Engines Operating with Materials that Give off Not Only Volatile, but also Solid Combustion Products (Reaktivnyye dvigateli, rabotayushchiye materialami, dayuschimi ne tol'ko letuchiye, no i tverdye produkty goreniya). Manuscript. F. A. Tsander Family Archives.

Kondratyuk, Yu. V. To Whomsoever Will Read in Order to Build (Tem, kto budet chitat', chtoby stroit'). Manuscript. Preserved in the Institute of the History of Natural Science and Technology, Academy of Sciences of the USSR).

Conquest of Interplanetary Space (Zavoyevaniye mezhplanetnykh prostranstv). Special Publication. Novosibirsk, 1929.

Photographic portraits were supplied by the following persons and organizations: portrait of N. I. Kibal'chich, by the N. E. Zhukovskiy Science-Memorial Museum; portrait of K. E. Tsiolkovskiy, by B. N. Vorob'yev, portrait of F. A. Tsander, by A. F. Tsander, portrait of Yu. V. Kondratyuk, by O. N. Gorchakova. /11

The works were selected and the collection compiled by Academician A. A. Blagonravov, Academic Secretary of the Commission for Developing the Scientific Legacy of K. E. Tsiolkovskiy, B. N. Vorob'yev, Doctor of Engineering Sciences Professor T. M. Mel'kumov, and Master of Engineering Sciences V. N. Sokol'skiy.

Preparation of the text was done by co-workers of the Institute of the History of Natural Science and Technology, Academy of Sciences of the USSR: I. V. Balandina, V. K. Kuzakov, M. I. Mosin, I. A. Paruntseva, and N. I. Rogacheva, under the direction of Master of Engineering Sciences S. A. Sokolva.

Substantial aid was rendered in preparing the scientific legacy of F. A. Tsander for publication by the scientist's daughter.

T. M. Mel'kumov

A Concept for an Aeronautical Machine

N 66-12165

15

N. I. Kibal'chich

I am writing this project in imprisonment, a few days before my death. I believe in the realization of my idea, and this faith sustains me in my terrible predicament. Should my idea, after careful examination by scientific experts, be recognized as feasible, then I would be happy that I have rendered a service to my country and to mankind; I would then meet death peacefully, knowing that my idea will not perish with me, but will exist among mankind for whom I was ready to sacrifice my life. Because of this, I implore those scientists, who will examine my project, to treat it as seriously and conscientiously as possible, and to give me an answer, concerning it, as soon as possible.

First of all, I am compelled to note that while being free I did not have enough time to work out my project in detail and to demonstrate its feasibility by mathematical calculations. At the present time, of course, I do not have the opportunity to obtain the necessary materials for this. Therefore, this problem, the support of my project by mathematical calculations, must be solved by the experts into whose hands my project falls.

Besides that, I am not familiar with the mass of similar projects that have appeared lately, i.e., it would be more correct to say that I am approximately aware of the concepts behind these projects, but I do not know the forms, in which, the inventors intend to carry out their ideas. But, as far as I know, none has yet presented my idea.

In my thoughts on the aeronautical machine, I first of all considered the question: what power should be used, in order to set this machine in motion? Reasoning 'a priori', one can say, that steam power is useless here. I cannot remember exactly what percent of the heat energy transmitted to steam by heating is utilized as work, but I do know that this percentage is quite small. In addition to that, the steam engine is cumbersome and requires a great deal of coal to make it work. I think, therefore, that whatever equipment may be attached to the steam engine, such as wings, airscrews, etc., the steam engine would not be able to lift itself into the air. 16

In electric motors, a much greater part of the imparted energy is utilized as work, but for a large electric motor, a steam engine is still required. Let us assume that both the steam engine and the electric motor can be constructed on the ground and that galvanic current can be transmitted by wires, similar to telegraph wires, to the flying machine which, sliding so to speak with a special metal part on the wires, will obtain the power capable of setting the wings or other similar devices of the apparatus, in motion. I will not try to prove that such construction of a flying apparatus is possible, but even if it were possible, it would, in any case, be inconvenient, expensive and would not have any significant advantageous over rail transportation.

Many inventors base the movement of the aeronautical apparatus on the muscle power of man, as is the case, for example, with Dr. Arendt. Using a bird as a model in designing their conceptual machines, they think that it is possible to construct devices which, when set in motion by the power of the flier himself, would permit him to rise and fly through the air. I think that even if it were possible to construct a flying device of this type, it would only serve as a toy and could not have any serious significance.

What power, then, is applicable to aeronautics? In my opinion such power is found in slowly burning explosives.

Actually, in the combustion of explosives, sooner or later a large quantity of gases is formed, which possess great energy at the moment of their formation. I do not remember exactly what amount of work in kilogram-meters, is produced by one pound of gunpowder when ignited, but, unless I am mistaken, one pound of gunpowder detonated underground, can eject block of dirt weighing 40 poods (obsolete; 1 pood = 36 lbs). In short, no other substance in nature possesses the ability to develop as much energy as explosives in as short a time.

But how can the energy of the gases formed on ignition of explosives be used to do some sort of work of long duration? This is only possible with the stipulation that if the enormous energy formed on combustion of explosives not form at once, but during a more or less protracted period of time.

If we take a pound of granulated gunpowder, which bursts into flames immediately on ignition, compress it under high pressure into cylindrical form and then light one end of this cylinder, we will find that flames do not encompass the cylinder at once, but will spread rather slowly from one end to the other with a definite speed. The speed of propagation of combustion in the pressed gunpowder has been determined by numerous experiments and turns out to be 4 lines per second (tenths of an inch per second - note 1, Commentary). /17

This property of pressed gunpowder is basically the working principle of military rockets. The essence of this principle consists in the following. Into a tin cylinder, closed at one main end and opened at the other, a cylinder of pressed gunpowder is tightly compacted, with a hole along its axis in the form of an open channel; the combustion of the pressed gunpowder begins from the surface of this channel and spreads, during a definite period of time, to the outside surface of the pressed gunpowder; the gases formed on combustion of gunpowder produce pressure in all directions, but the lateral pressures of the gases are mutually compensating, while the pressure on the bottom of the tin shell holding the gunpowder, failing to be offset by counter pressure (because the gases have a free exit in this direction), pushes the rocket forward in the direction in which it is initially mounted on the stand prior to ignition. The flight trajectory of the rocket comprises a parabola similar to the trajectory of bullets fired from weapons.

Let us imagine now that we have a cylinder, made from sheet iron and having known dimensions, hermetically sealed on all sides, with only a certain size opening at the bottom. Let us place along the axis a piece of pressed gunpowder

in a cylindrical form, and light it from one of its bases.¹ On combustion, gases will be formed, which will exert pressure on the whole inner surface of the metal cylinder, but the pressures on the side surface of the cylinder will be mutually compensated, and only the gas pressure on the sealed bottom of the cylinder will not be equalized by counter pressure, since from the opposite side the gases have a free exit through the opening in the bottom. If the cylinder is placed with the sealed bottom on the top, then with a certain gas pressure, whose amount depends, on the one hand, on the inner holding capacity of the cylinder, and on the other hand, on the thickness of the piece of pressed gunpowder, the cylinder must rise.

I do not have data near at hand that would permit me to determine, at least approximately, what amount of pressed gunpowder must burn up in one unit of time in order that, with a cylinder of known dimensions and known weight volume, the gases formed on combustion of the gunpowder, could exert sufficient pressure on the bottom to equalize the force of gravity on the cylinder. But I think 118 in practice this problem is quite solvable, i.e., with given dimensions and weight of the cylinder, it is possible, using cylindrical pieces of pressed gunpowder of known thickness, to achieve the level at which the gas pressure on the bottom would balance out the weight of the cylinder. Rockets serve as actual proof of this. At the present time, rockets are being produced which can lift up to 5 poods (180 lbs.) of explosive shells. It is true that the rocket example does not exactly fit here, because the rockets are distinguished by such enormous speed of flight, which is unthinkable in the case of an aeronautical machine, but this speed is produced because of the substantial quantity of pressed gunpowder that is put into the rocket and its large surface of combustion. If a much slower speed of ascent is required, then the quantity of gunpowder that burns out in one unit of time must also be much smaller.

Thus, we have a diagrammatic description of my device (fig. 1). In the cylinder A, which has an opening C in the bottom, the gunpowder candle K (as I call the small cylinders of pressed gunpowder) is installed along the axis near the top. The cylinder A, with the help of the stands N, is attached to the middle part of the platform P, on which the flier must stand. For lighting the gunpowder candle and for replacing it with a new candle when it burns out (during this, of course, there should not be an interruption in combustion), new automatic mechanisms should be devised. Hence, for installation of the gunpowder candles, as soon as they burn out, the most applicable automatic device would be a device actuated by a clock mechanism, owing to the even, predictable combustion of the gunpowder candles.

But I will not deal with these devices here, because all this can be easily solved by present day technology.

¹I do not know exactly whether it is necessary for maintaining the conditions of slowness and evenness of combustion to enclose the pressed gunpowder in a tightly fitting shell. But even if this enclosure into a shell were necessary, it would, not in any way prevent the use of pressed gunpowder in the construction of the apparatus.

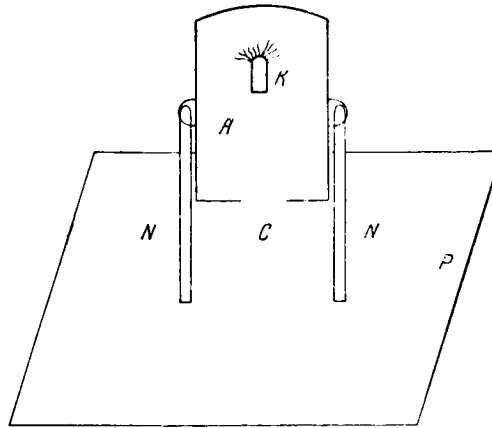

Figure 1

Let us imagine now that the candle K has been lit. After a very short period of time, the cylinder A is filled with hot gases, part of which press 19 upon the top of the cylinder, and if this pressure surpasses the weight of the cylinder, platform and aeronaut, the device must rise.

We note, by the way, that it is not only the force of the gunpowder gas pressure that contributes to the device's ascent; the hot gases filling the cylinder A have a lower specific gravity than that of the air displaced by them; therefore, on the basis of the aerostatic law, the device must become lighter by the difference between the weight of the air filling the cylinder A and the weight of the gunpowder gases in it (note 2, Commentary). Therefore, here again we encounter the circumstance which is favorable to the ascent of aerostats, through the pressure of the gases, the device can rise very high, provided the amount of gas pressure on the top is greater than the weight of the device at the time of ascent. If one wishes to stop at a certain height in a motionless state, then it will be necessary to install gunpowder candles that are less thick, so that the pressure of the gases formed will be just equal to the weight of the device.

In this way, the aeronautical device can be placed in the same relation to the air medium as a ship standing motionless in relation to water. How can we now move our apparatus in a desired direction? For this, two methods are suggested.

It is possible to employ a second, similar cylinder, but oriented horizontally and with the opening in the bottom pointed to the side rather than downward. If a similar device with gunpowder candles is installed into such a cylinder and the candle lit, the gases hitting the bottom of the cylinder would make the device fly in the direction in which the base is pointed. In order for a horizontal cylinder to be installed in any direction, it must be movable in the horizontal plane. To ascertain direction, a compass may be used in the same way that it is used in navigation on water.

But it seems to me, that we can limit ourselves to one cylinder, if it is constructed such that it could be inclined in the vertical plane and that it also would be capable of conical rotation. Both the support of the apparatus in the air and moving it in a horizontal direction, are achieved by inclination of the cylinder. Hence, let us assume that the force due to the gas pressure on the bottom of the cylinder is expressed graphically by P; we divide this force into its components Q and R. If the force Q is equal to the weight of the device, then it will fly in the horizontal plane, being moved by force R. Therefore, the cylinder must be inclined to such an extent that the flight would take place in the horizontal plane. In order for it to fly in a pre-determined direction, it is necessary to point its axis in this direction by rotating the cylinder in conical fashion.

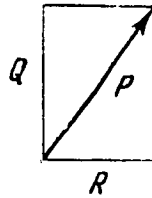

Figure 2

But with two cylinders we achieve, it seems to me, a more controlled flight and a more stable apparatus. Actually, with two cylinders, the vibrations of the apparatus as a whole tend less to divert it from the desired direction than with one. In addition, with one cylinder it is more difficult to reach the speed attainable with two. /20

As far as the stability of the apparatus is concerned, it seems to me that it will be sufficient, since the cylinders are located above the heavy parts of the apparatus and due to this, the center of gravity of at least one of them, for example the top one, is located on a vertical line with the center of gravity of the apparatus. However, some kind of motion regulators, such as wings, etc., i.e. can be devised for stability.

For the apparatus' descent to earth it is necessary to gradually install gunpowder candles of lesser diameters, whereupon the apparatus will gradually descend.

In conclusion, I wish to note that pressed gunpowder is not the only medium which need be used for this purpose. There are many slow-burning explosives in existence, in whose composition even potassium nitrate, sulfur, and coal can be found, just as in gunpowder, but in other proportions or with the admixture of other substances. Perhaps one of these compositions will turn out to be even more convenient than pressed gunpowder.

Only through experimentation will it be possible to find out whether or not my idea is valid. Also from experiment, it should be possible to determine

the necessary relationships between the size of the cylinder, the thickness of the gunpowder candles, and the weight of the apparatus to be raised aloft.

Initial experiments can be easily performed with fairly small cylinders, even indoors.

23 March 1881

COMMENTARY

638

This article was written by N. I. Kibal'chich in prison, a few days before his execution. It is noted in the minutes of the trial of the March First revolutionaries that the defense attorney for Kibal'chich, V. N. Gerard, on first meeting his defendant, was struck by the fact that the latter "was totally preoccupied with another matter, in no way pertaining to the present trial. He was immersed in research that he was conducting on some kind of flying machine; he was eager to be given the opportunity to write down his mathematical inquiries relating to this invention. He wrote them down and presented them to the authorities" (Kibal'chich, ref. 4).

However, the hopes of Kibal'chich that his concept would be properly evaluated by scientific experts did not materialize. The following notation was made in an ancillary note to this concept: "Attach to the Affair of 1 March. To submit this for the consideration of scientists would scarcely be propitious at this time and could elicit only inappropriate interpretations" (Kibal'chich, ref. 5, sheet 235).

Not receiving any reply, Kibal'chich once again appealed to the Minister of Internal Affairs with a request that he be given the opportunity to hear the opinion of scientists or at least to obtain an opinion in letter form from experts as to his invention (Kibal'chich, ref. 5, sheet 280a), but again his request was not carried out.

After the death of Kibal'chich, his concept was sent to the archives of the police department. News concerning it found its way into print, but in greatly distorted form.

Only after the February Revolution of 1917 was the concept taken from the archives and published with annotations by N. A. Rynin in the journal *Byloye* (Former Times) (Kibal'chich, ref. 1). In the present collection the text is published in the original, which is now preserved in the Central State Archive of the October Revolution in Moscow (Kibal'chich, ref. 4, sheets 1-5; autograph without signature).

Note 1, page 10. One line = 2.54 mm.

Note 2, page 12. This is not of any practical significance.

TO WHOMSOEVER WILL READ IN ORDER TO BUILD

N 66-12166
501

Yu. V. Kondratyuk

Above all, do not be frightened by the theme of this paper nor distracted from the realization, difficult as it might be to comprehend, that from the theoretical viewpoint rocket flight into outer space is nothing astonishing or improbable.

I will have frequent occasion to use phrases which are quite inadmissible in scientific writing, such as: "not too large," "sufficiently," etc., without indicating anything exactly. This is because I do not have on hand the materials for drawing the line between "sufficient" and "insufficient," in fact a good part of the materials needed for the construction of a rocket still have not been assembled.

On less frequent occasion, this is dictated simply by a disinclination to carry out the computations, which anyone can perform.

Allow me to say a word about terminology; in many instances, I have made up my own, in many others I have probably adulterated existing terminology, so that if such happens to be the case it should not be puzzled over, but probed for substance of meaning.

The realization of this undertaking will require tests, tests, and more tests on an ever-increasing scale. A gradual approach must be exercised particularly in flights with people. In such a new area, it is impossible to foresee everything, and in interplanetary space help is to be expected from nowhere.

General Theory

The first stipulation for flights from earth and back is that they do not risk the lives of the passengers.

The second stipulation is that they be maneuverable.

The first stipulation requires, first, that the mechanical accelerations imparted to a vehicle carrying passengers should not exceed a definite threshold, above which this acceleration could be harmful or fatal to humans; second, that a vehicle with passengers on board must be hermetically sealed to prevent the escape of air, this air must be maintained fresh, and the temperature of the vehicle must be kept normal. All of the latter conditions are easily met, but the first requires some discussion; in order for the vehicle to be able to overcome the earth's gravitational pull, it must acquire a tremendous velocity (about 11 kilometers per second) (note 1, Commentary). In order to gain such a velocity without mortal consequences, acceleration must be imparted over a rather long period of time (in hours) and over a very long distance (hundreds of kilometers). Any sort of cannon, in the conventional sense of the word,

besides the fact that it cannot communicate the necessary velocity to the vehicle with today's materials, is totally unsuitable for the additional reason that a man seated in the projectile would be mashed to a pulp at the bottom of the vehicle.

It is conceivable, of course, to construct an electric "cannon" several hundred kilometers in length, which would comfortably supply a velocity of 11 km/sec, but such an item would be very costly and would not solve the problem of the return trip to earth or of maneuverability.

Consequently, the cannon must be abandoned; this leaves the sling principle and reactive device. The sling is unsuited to the purpose at hand for the same reasons. It requires tremendously bulky equipment (so that the man will not be crushed) and does not solve the return-trip problem. The reactive device is left.

The second stipulation, maneuverability, eventually leads to the reactive device, since in the celestial void there is no point of support other than that which is taken with oneself.

The problem, then, is the following: Is it possible in general theoretically for a reactive device to develop a velocity of 11 km/sec and to recover it for the return trip, and does this require dimensions that are impracticable or very difficult to realize. We will consider the rocket as a reactive device, since any other type than comes into my mind is either unrealizable due to the enormous dimensions required, or the problem of realizing it calls for prior investigations which, at the moment, I am unprepared to carry out.

A Theoretical Formula for the Weight of the Rocket

Let us suppose that we have a substance (which we will henceforth call the "active" substance) or a composition which can perform p ergs of work per gram and that we can utilize all of this work to expel this (the usable amount) substance from the remaining body of the rocket.

Let the mass of the entire body of our rocket be equal to m grams, and let 503 us burn up (henceforth we will use this expression instead of "using energy," because this is in fact what happens) an infinitesimal quantity h grams of the active agent, using up the developed energy ph to expel the quantity h (which is precisely the substance that we have burned up) from the remaining body of the rocket. As the two bodies are pushed apart the energy (kinetic energy) relative to their common center of gravity is distributed between them in inverse proportion to their masses, hence the remaining body of the rocket (whose mass is $m - h$) acquires as its portion

$$hp \frac{h}{(m-h) + h} = \frac{h^2 \cdot p}{m} \text{ erg.}$$

We translate this work into velocity (continuing to regard the mass of the rocket as m , since the loss h is insignificant).

$$\frac{m \cdot V^2}{2} = \frac{h^2 p}{m}; \quad V = \sqrt{\frac{2h^2 p}{m^2}} = \frac{h}{m} \sqrt{2p} \text{ cm/sec.}$$

We see from the resultant expression $\frac{h}{m} \sqrt{2p}$ that, other than the properties of the active agent (p), the imparted acceleration depends only on its relative proportion, h/m , or, what amounts to the same thing, on the ratio of the total mass (m) to the passive part ($m-h$):

$$\frac{m}{m-h} = 1 + \frac{h}{m} \left(\text{since } h = \frac{1}{\infty} \right).$$

Consequently, every time that we burn up an amount of active agent in this proportion, the indicated acceleration will be obtained, and whatever the ratio of the required velocity V to the derived velocity $\frac{h}{m} \sqrt{2p}$, this is the amount of active agent that must be burned up in proportion to the ratio of the total mass to the passive part: $1 + \frac{h}{m}$; i.e., to develop a velocity V it is necessary to burn an amount in the given ratio $\frac{V m}{h \sqrt{2p}}$.

Therefore, the ratio of the starting mass of the rocket to that which remains will not be $1 + \frac{h}{m}$, but $\left(1 + \frac{h}{m}\right)^{\frac{V \cdot m}{h \cdot \sqrt{2p}}}$. We transform this expression,

relying on the fact that $h = 1/\infty$.

$$\left(1 + \frac{h}{m}\right)^{\frac{V \cdot m}{h \cdot \sqrt{2p}}} = \left(1 + \frac{1}{\infty}\right)^{\frac{1}{h} \frac{V}{\sqrt{2p}}} = e^{\frac{V}{\sqrt{2p}}}$$

Consequently, denoting the mass of the entire rocket by M , the mass of the passive load by m , we have the formula

504

$$M = m e^{\frac{V}{\sqrt{2p}}}$$

We conclude from the resultant formula that it is always possible to impart any velocity V to a given mass m , even if only a mildly active substance is involved (p), and its activity only affects the size of the rocket M , which of course increases very rapidly with decreasing p and could very quickly overstep the bounds of practicality.

Derivation of a Formula in Application to
the Potential Energy of the Earth's Gravitation

The potential energy of the earth's gravitation is equal to rj , where r is the radius of the earth, j is the gravitational acceleration for any point outside the earth's surface. We transform rj to velocity:

$$rj \text{ ergs} = \frac{V^2}{2} \text{ cm/sec}^2 \quad (\text{note 2, Com.}); \quad V = \sqrt{2rj} \text{ cm/sec} \quad (\text{note 3}).$$

We substitute into the general equation

$$M = me^{\frac{\sqrt{2rj}}{\sqrt{p}}} = me^{\sqrt{\frac{rj}{p}}},$$

This is the formula for flight away from the earth; in order for this velocity to be recovered for the return trip, it is necessary to have twice the same mass. We obtain

$$M = me^{2\sqrt{\frac{rj}{p}}}$$

$$\ln M = \ln m + 2\sqrt{\frac{rj}{p}}$$

A partial calculation, assuming $p = 10/3$ kcal/g (approximately the calorific value of $H_2 + O$), yields

$$M = me^{2\sqrt{\frac{600\,000\,000 \cdot 1000 \cdot 3}{42\,800\,000\,000 \cdot 10}}} = \text{approx.} \quad me^4 =$$

$$= \text{approx.} \quad 551$$

The ratio 55 (even though it is a theoretical minimum and should perhaps in practice be set equal to 100, 200, 500, or 1000) is not an unreasonable figure; the rocket is entirely practicable!!!

(All of the symbols that I use are expressed in absolute units, and my calculations are in the same units.)

In deriving the above formulas, we did not include in our calculations the period in which acceleration would be imparted. These formulas are exactly applicable only for the case when the acceleration is imparted instantaneously, because as long as we are imparting acceleration to the vehicle away from earth, the earth's gravitational field imparts an acceleration toward the earth, and the longer the period of time in which we impart acceleration to our vehicle the greater will be the acceleration that can be imparted to it in the opposite direction by the earth's gravitation, and this acceleration must then be compensated by the active agent. (This argument becomes clear from the following: If we impart to the vehicle away from the earth an acceleration equal to the earth's gravitational acceleration, our vehicle would not go anywhere, but would hover in the air.) Consequently, from this point of view, the greater the acceleration that is imparted to the vehicle, acceleration per unit time until the required velocity is attained, the better. But, first of all, man cannot withstand an acceleration (imparted mechanically) greater than some definite maximum (the way to raise this level is discussed below). Furthermore, the vehicle must be made stronger in proportion to the amount of acceleration, i.e., the passive load must be increased. Therefore, we will not impart to the vehicle an acceleration greater than some given value q . We will call the ratio q/j (where j is the earth's gravitational acceleration) k . It is expected that k will be of the order 5 or 10.

First Method of Flight and its Formula

The first method of flight consists in imparting to the vehicle an acceleration directly away from the earth in a radial direction (or, if not radially, in one fixed direction), and for the return flight imparting the same acceleration in the reverse radial direction, toward the center of the earth. Let the ratio of the imparted acceleration to the gravitational acceleration be k . Although k will increase on ascending away from the earth due to diminution of the earth's gravitation, I will assume for the present calculation that it is constant (or that it does not vary too appreciably, especially when it is large (5-10) at the start), in order to avoid complicating the calculations unnecessarily. Thus, of the total acceleration imparted to the vehicle kj , $1 \cdot j$ will be used in overcoming the earth's gravitation, the remaining $(k-1)j$ comprising the effective part, i.e., the activity of the substance in the sense of communicating velocity will be lowered by a factor of $\frac{k}{k-1} = 1 + \frac{1}{k-1}$.

This factor of $1 + \frac{1}{k-1}$, therefore, must be substituted in the exponent of the mass formula:

$$M = me^{2\sqrt{\frac{r}{p}} \left(1 + \frac{1}{k-1}\right)}$$

Even if $k = 5$, the factor $1 + \frac{1}{k-1}$ in the exponent represents a very vexing quantity.

Second Method of Flight and its Formula

The second method of flight consists in imparting to the vehicle an actual acceleration in a direction perpendicular (roughly) to the radius vector and returning along a tangential direction with the reverse acceleration, again perpendicular to the radius (fig. 1).

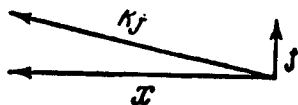

Figure 1

From the velocity parallelogram we find the actual acceleration, if to our vehicle we impart an acceleration such that when added to the gravitational acceleration it will give the actual acceleration perpendicular to the radius:

$$x = \sqrt{k^2 j^2 - j^2} = j \sqrt{k^2 - 1}.$$

With the communication of such an acceleration, the activity of the substance is lessened by a factor of $\frac{k}{\sqrt{k^2 - 1}}$, and this only at the very beginning. As velocity and centrifugal force are developed, this ratio will approach unity.

When the vehicle attains the velocity at which the centrifugal force becomes greater than j , the vehicle will have a tendency to move about the earth in an ellipse. By imparting velocity to it in those parts of its flight path where it is most perpendicular to the radius, near the ends of the major axis, we will obtain an activity coefficient near unity. The return trip is by the same means. Inasmuch as I am not able to perform all of the computations, I

will use in the formula the ratio $k / \sqrt{k^2 - 1}$, which is worse than any efficiency factor but which is still very good, incomparably better than $k/k - 1$; even

for small k the coefficient $k / \sqrt{k^2 - 1}$ is very near unity.

$$M = me \sqrt{\frac{rj \cdot k^2}{p(k^2 - 1)}} = \langle me \sqrt{\frac{rj}{p} \left(1 + \frac{1}{k^2 - 1}\right)} \rangle$$

Here is an approximate drawing of the vehicle's path (fig. 2).

507

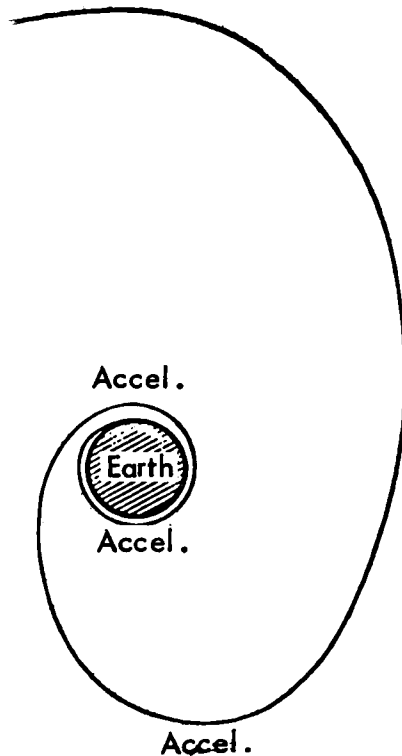

Figure 2

Thus, the second means is far more complex in the sense of control, but it requires considerably less active agent (if k is not particularly large, say 20).

Note: Subject to the influence of the force of gravity (which is appreciable), it will always be true in general that the more judiciously we utilize the active agent, the more perpendicular to the direction of gravity we will impart acceleration (but here, of course, it must be remembered that the more judicious acceleration is imparted parallel to the already existing velocity). The second means of flight is the application of this principle (note 4, Commentary).

/508

On Techniques for Increasing
the Endurance of the Human Body with Respect to
Appreciable Mechanical Accelerations¹

As we have seen, the limited endurance of man with respect to accelerations, especially in the first flight method, is a very detrimental factor in the rocket weight formula. We will now describe in general terms the reasons for nonendurability and how they might be coped with in some measure.

The reasons for lack of endurance are the limited strength of the body, the presence of fluid elements, and differences in the absolute density of the constituent parts of the organism. As we know, if a man falls from a great height his members will be broken, i.e., his body will not withstand the acceleration imparted to it by the ground surface. Then, of course, if a man spends a long period of time in a situation that is unfamiliar to him, for instance upside-down, or, better yet, spinning rapidly about some point, his blood, due to the acceleration of gravity in the former instance (centripetal acceleration) and centrifugal acceleration in the latter, will rush to certain parts of his body and drain from others. In magnified form, this effect terminates in rupture of the vessels in those portions of the body filled with blood.

The injurious effect of the third factor, differences in density of the constituent parts of the body, in normal living is not pronounced, but can be manifested upon acquiring appreciable acceleration. In the chest, where this difference is the greatest, a heavy organ - the heart - and the organic part of the lungs together with the blood contained in them are found side by side and in disordered fashion with air contained in the lung sacs. Excessively large acceleration can result in blood discharge in the lungs, collapsing of the lungs, and subsidence of the heart in the lungs.

This is how the harmful consequences of mechanical acceleration can be overcome (provided it is not excessively high, say 1000 m/sec^2 (note 5)), without sacrificing the latter: The man, completely nude, lies on his **back** in a form specially contoured to provide a snug overall fit to his figure. This form comes up to a little more than half the thickness of his body, as indicated by the heavy line in the figure (fig. 3).

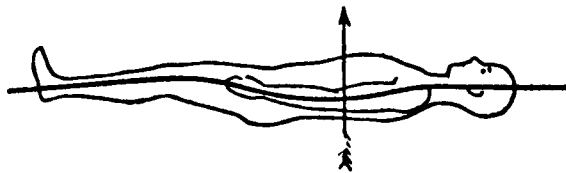

Figure 3

¹By "mechanical" I mean acceleration that is imparted mechanically, i.e., by exerting pressure, for example. This is the only acceleration that can be detected, while acceleration imparted by gravity cannot be detected by any means on the body itself.

The direction of acceleration is indicated by the arrow. In this position, the pressure will be distributed uniformly over the entire backside of the body, and all of the harmful effects, except for the process in the chest, will be greatly mitigated. If the acceleration is not so large as to call for such measures but is still considerably larger than the acceleration of earth's 509 gravitation, it is recommended that the man lie on something, mainly being careful that the body does not extend anywhere too far in the direction of acceleration, so as not to obtain rushing of the blood in some places and draining in others; either is proportional to the height of the blood column, i.e., the extent of the body in the direction of acceleration. It is also possible that reliance on a contoured form would not be at all suitable, if below the acceleration for which this would be required any undesirable effects occur in the lungs (of course, this would not be affected by the form). Experiments relating to all of this are not difficult to set up with a man on a large centrifugal device employing centrifugal force.

Concerning Other Possible Reactive Devices

1. A mechanical reactive device consists of a wire coil whose center is connected to the passenger chamber. If we impart to the coil a sudden rotation (opposite to the sense in which the wire was coiled) and then release the end of the wire, it will fly along a tangent to the circle in one direction, while the coil with chamber will fly in the other direction (fig. 4).

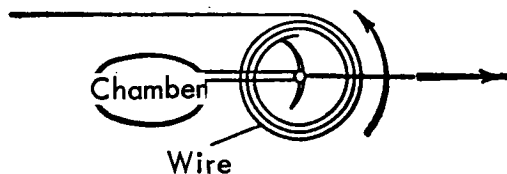

Figure 4

This kind of device is unsuitable for flights from the earth, because a wire coil made of even the best steel cannot possibly withstand rotation at a velocity (absolute, irrespective of the radius) greater than about 300 m/sec; above this the coil cannot withstand the centrifugal force and will break.

Because of the low attainable velocity, it would be necessary to build the device with enormous dimensions: approximately $M = m.55^{10}$ 510

2. Reaction from Material Emission. - Cathode rays represent particles with mass, which are charged and travel at velocities of 200 000 km/sec. Consequently, they yield a corresponding reaction, or recoil, and could be utilized, provided the necessary intensity were attained. Their drawback is the tremendous amount of energy required, and their velocity is greater than need be; the larger the velocity, the greater the amount of energy that we must expend to obtain the same reaction, and they are accompanied by a high electric charge of high potential that serves no purpose. It is possible, however, that any dissipation of energy could probably be eliminated by passing these rays

through an anode layer, wherein they could lose their surplus velocity and charge, and we could again utilize the heating of the anode. Even though right now a reactive device based on material emission seems very difficult and unlikely to me, it is nevertheless worth thinking about and working on; in the event that it succeeds, it promises to give as colossal a velocity as could be given to even the most gigantic rocket. It would perhaps be possible to test the theory of relativity. The energy for such an apparatus can only be taken from the rays of the sun, either our own or another (see the discussion of reflectors and solar energy) (note 6).

General Form of the Vehicle

The vehicle consists of a chamber to house the passengers, instruments, and, in compact form, the control mechanisms; tanks for the active agent; and tubes in which combustion and expansion of the active agent and its gases take place (as they expand, these gases press on the tube, imparting acceleration to the vehicle, while they themselves escape from the latter in the opposite direction). The tanks for the active substance must be several rather than just one, because one tank would weigh considerably even at the end of the flight when almost all of the active agent is spent, constituting a totally unnecessary mass, which might weigh down the vehicle severalfold and require a large quantity of active agent and could even render the whole undertaking unfeasible. For this reason, there must be several tanks of various dimensions. The substance is first used up from the large tanks, after which they are simply rejected, and the agent from the next tank begins to be used. The dimensions of the tanks should be calculated so that the weight of the spent tank (one empty tank) will amount to the same portion of the entire remaining rocket for all tanks (note 7). This portion needs to be worked out, first with acknowledgment for the requirement that this portion be as small as possible, second, for the fact that the number of tanks should not be too large, so as not to com- 511 plicate the construction of the vehicle excessively. Figure 5 gives a schematic representation of what I consider to be a suitable form for the vehicle; the chamber is approximately spherical, the tanks are in the form of conical layers (approximately congruent). They are made in the form of layers so that they will extend less in the direction of acceleration and so that large pressure will not be produced in them (high fluid column). It is not a good idea to make the cone too broad nor too long; in both cases the strength of the tanks should be increased with allowance for acceleration, and in the first case with allowance for pressure (the active agent consists of liquid gases, oxygen and carbon).

In order for it to be possible to make the bottom of the tanks flatter, without making them heavier, it might be more appropriate to run tie rods to them from the point of application of force a (gas pressure on the tube), to which all of the tanks are then connected by the rods and in which the tube is secured.

If for some reason liquid oxygen and hydrogen cannot be held together in the mixture, it will be necessary to provide each tank with two compartments (note 8), one above the other. In correspondence with the several tanks, the 512 tube should also be altered with the rejection of old tanks, either by

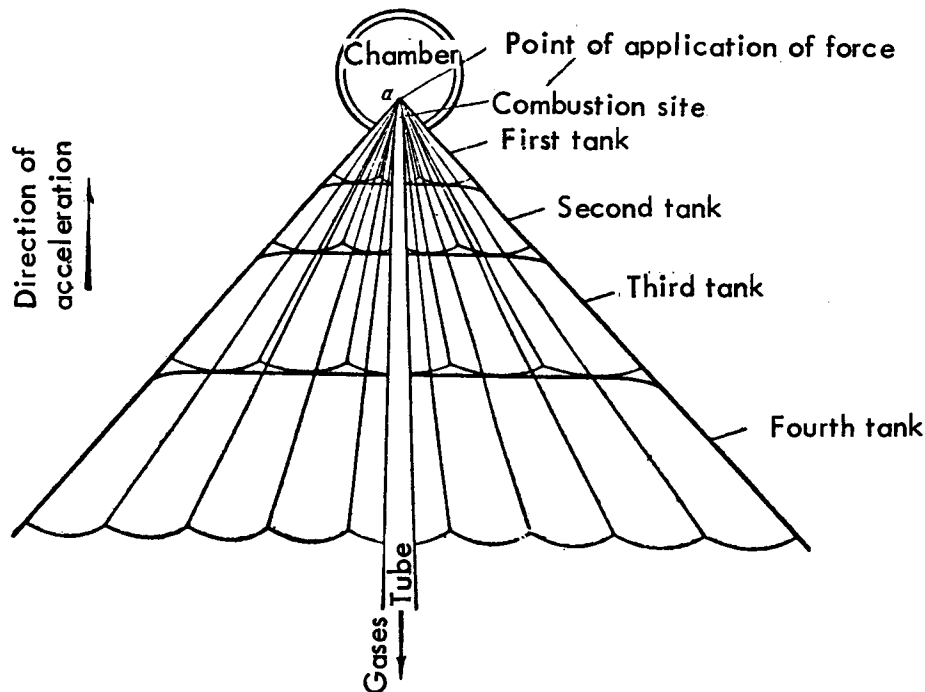

Figure 5. Schematic Section of the Vehicle.

discarding the projecting member of the tube and shifting the combustion region or replacing the whole thing with a new one; the best approach will be determined by experiments. The chamber, of course, is airtight, well heated, with equipment for freshening the air.

It must be found out experimentally whether man can breathe an oxygen-hydrogen atmosphere; if so, things are greatly simplified.

Theory of the Tanks

Relative to expansibility <of the contents>. - Let us assume the tanks contain an ideal gas. We will consider the ratio (advantage) of the weight of the tank to the weight of the amount of gas that it can just hold (the thickness of the walls are used nowhere in the calculation, only their strength (in shear)).

Simple computations show that the advantage of such tanks does not depend at all on their dimensions, and for the same gas at the same temperature it never depends on the expansibility; that the most advantageous tanks are a hollow sphere and a long (infinite) cylinder (tube), the cylinder turning out to have a slightly higher advantage than the sphere (π for the cylinder, 3 for the sphere) (note 9).

Relative to acceleration. - We will now investigate a tank filled with a ponderable liquid, to which some ("mechanical") acceleration is imparted. The force producing the acceleration is applied to the tank.

Simple computations show that for such tanks the advantage is inversely proportional to the lengthwise dimensions (larger tanks are less advantageous); that the advantage is always inversely proportional to the magnitude of the acceleration; that the advantage is inversely proportional to the cube root of the absolute density of the liquid (for the same given amount); that for a cylinder whose axis is parallel to the direction of acceleration, if its bottom is not included in the computation, the advantage does not vary with the radius and is inversely proportional to the height; that the most advantageous shape for the tank is one bounded above (assuming downward acceleration) by a plane; that this shape is something like a hemisphere; that the most advantageous shape has only one flat surface, the one bounding it from above; that the advantage of the tank is increased with more uniform application of the force to the bottom of the tank, in which case it becomes more advantageous to make the tank wider and flatter (the same rule applies to an assemblage of interconnected tanks). On the basis of all the above, it becomes fairly evident why I have chosen for my vehicle tanks in the form of conical layers tied by rods to the vertex.

Construction of the Vehicle; Control and Stability

513

In order for us to be able to control the vehicle properly, we must be able to turn it in space in all directions, i.e., to rotate, together with rotation of the vehicle-tube, the direction of the emerging gases, i.e., the direction in which acceleration is transmitted, and we must be able to hold to a given direction at will, so that the vehicle will not go astray in space due to an unavoidable but large irregularity of the load (its center of gravity not being on a line with the applied force), tracing out a spiral or circular path. A predetermined course can be held by using a biaxial astatic gyroscope (note 10) (see the section entitled "The Biaxial Astatic Gyroscope"), and its direction can be altered by means of a thrust attachment at the end of the tube (fig. 6).

If we work with thrusts, then a short tube attached to the end of the tube by means of Cardan joints, being narrow enough not to interfere with the normal gas glow, deflects the pressure of the stream when rotated slightly, thus imparting to the entire vehicle the rotational moment needed for changing direction. If possible, it may not be necessary to construct this entire accessory, but to create thrusts directly at the end of the tube so that they will tend to turn it slightly in a desired direction. Here we have a lever arm to which all four thrusts will be imparted (fig. 7).

The point of rotation a of the lever should be in the same plane as all four of the pulleys B. Then the action in one direction will not detract altogether from the others. We note that this single lever system for controlling turning in all directions can also be used in other situations, for example aeroplanes, where the rudders and elevators are combined in one control device as, for example, a cylindrical surface, with control by means of a single stick.

Control is accomplished in the following manner. The gyroscope (its 514 frame) is housed in a yoke, which is rigidly secured to the body of the rocket. This yoke, when we need to hold a given course, is clamped; hence the body of the rocket is rigidly attached to the gyroscope, and it will in general remain stationary. When we need to execute a turn we release the yoke and make the turn freely, since the gyroscope is disengaged; we then clamp the yoke in place again. That's all there is to it.

The Biaxial Astatic Gyroscope (note 11)

The biaxial system consists of two gyroscopes in a single frame, their axes not parallel (perpendicular). The ordinary uniaxial gyroscope is countered by the rotation of the frame in all directions except that in which it spins itself, so that it does not always provide reliable support. If we build the gyroscope in biaxial form (see above), the total frame for both components of the gyroscope will be protected against rotation in all possible directions; wherever one of the gyroscopes is not countered the other will be completely countered. To make the frame of the biaxial gyroscope with approximately the same stability in all directions, it is necessary to make both gyroscope components of equal resistance (to rotation of their axes). For convenience, we 515 will make both gyroscopes in the form of hollow bodies of rotation and insert one within the other (fig. 8).

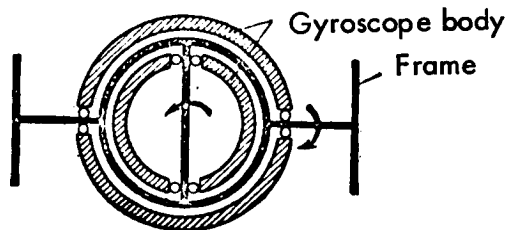

Figure 8

I use the term astatic to describe a gyroscope that reacts identically to rotation of its axis in a given direction as in the exact opposite sense, i.e., a gyroscope that is not given to any sort of nutation, precession, etc. The ordinary gyroscope will thus be unsuitable for the vehicle, for although it may rotate the vehicle in one desired direction it may not do the same in the direction perpendicular to that one. In order to build an astatic gyroscope it is necessary to combine two gyroscopes of the same resistance to rotation in a single frame, such that their axes coincide, while the directions of rotation are opposite (fig. 9).

The two gyroscopes so joined will tend to oppose all nutations, etc. with an equal and opposite force and, in this sense, nothing will happen, which is the required result.

The term "biaxial astatic" refers to a biaxial gyroscope, both components of which are astatic. Here is a schematic drawing (fig. 10).

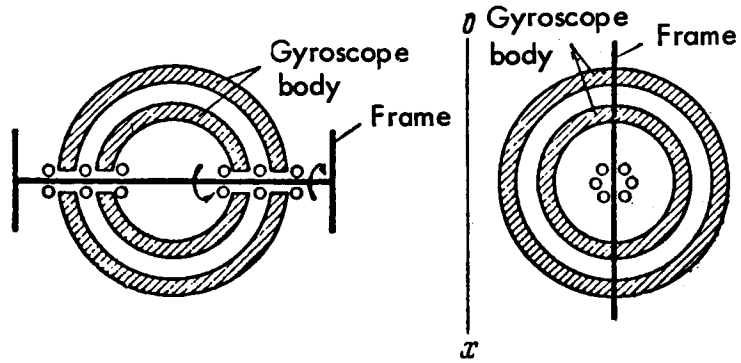

Figure 9

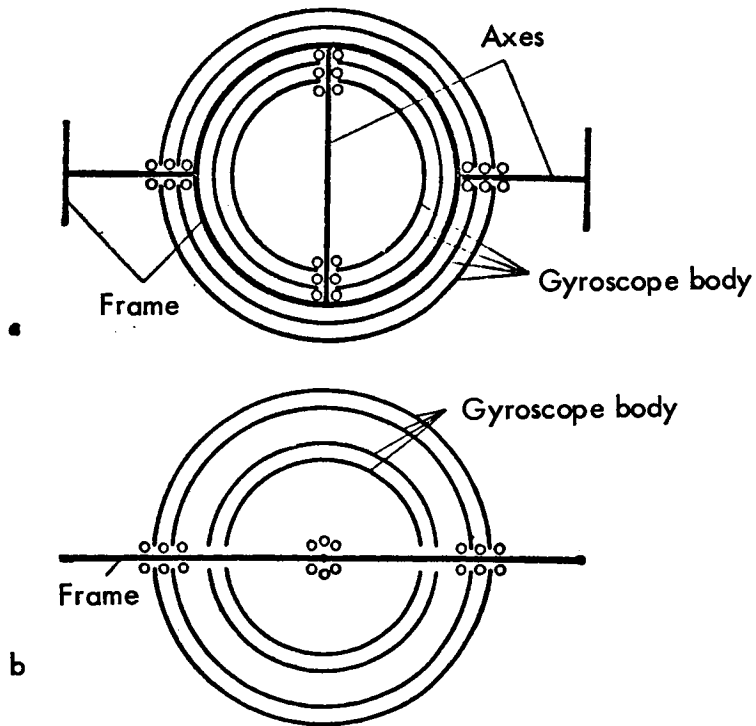

Figure 10

a) Schematic section in the plane of both axes; b) schematic section parallel to one axis (outer), perpendicular to the other (inner).

The frame of our gyroscope is hermetically sealed inside a hollow sphere, which is then inserted in the spring-clamped yoke. The appropriate rotation of all four bodies of the gyroscope does not impose particular difficulties. It is transmitted mechanically in sequence from the external to the internal system and is driven by some kind of very small (electric) motor. As the weight of the entire rocket decreases due to combustion, the gyroscope can be replaced by smaller ones and the large ones rejected. /516

The Chamber

The chamber should have a window for observation purposes and an opening, closed off by airtight doors, for the discharge of refuse.

In order to discharge anything, we open the upper door, deposit the waste matter on the lower door, close the upper, then open the lower one; the refuse is ejected and we once again close the lower door (note 12).

For control of the vehicle it is necessary to have communication between the interior of the chamber, i.e., the passenger quarters, and the external part of the rocket. This can be done by passing electrical wiring or pneumatic lines or simply connecting links through the walls of the chamber. There are no problems in the first two methods, but they are complicated, whereas the last method is simple but must be installed so that air will not escape from the chamber. This is how it is done: The connecting link (in the form of a tube, for thickness) runs through the wall via an opening of approximately the same size; the link is enclosed in a rubber tube, which fits it hermetically; this tube is twisted and hermetically fitted to the wall of the chamber so as to surround the opening for the connecting link. In this way, it enables the link to be moved in and out in that part of the rubber which is fitted to the opening; some kind of lubricant must be used between it and the link so that the rubber will not be squeezed under small pressure. /517

Perhaps it will be possible simply to polish and seat the link in the opening such that air leakage will be a factor of safe magnitude; this would be best of all. (We always have oxygen and hydrogen in tanks.) Special plugs will have to be used for the openings of those links that are discarded during flight (which includes the majority of them, since as the tubes and tanks are rejected their appurtenant control links must also go).

If the chamber is so arranged that a full-circle field of view is possible, it will be necessary to furnish it with optical devices permitting vision in a full circle.

The Active Agent and its Combustion

The active agent is a fulminating gas. It is best stored in solid form (note 13) so that the pressure of the gases inside the tanks will be minimized, since too much pressure will load them excessively. For proper combustion the hydrogen and oxygen should be stored separately (each one in such a state, i.e., at such temperature, that the pressure of the saturated gases will be a minimum). So that uniform pressure and uniform issuance of the gases will exist in the tanks, we must supply the tanks with an amount of heat necessary for

vaporization or sublimation. This heat will be delivered by the circulation of the hot hydrogen in the tube via tubes (heaters) running through the tanks (more on this arrangement below).

The gases will emerge from the tanks into pumps, which raise their expansibility to the point where it can exit from the combustion region and heaters into the tube (also more on the construction of the pumps below).

The actual combustion can be produced by three means; either the already hot mixture will ignite, the gases will not be mixed until the instant of ignition, or they will be only partially mixed just prior to this instant. Experience will tell which of the three methods should be used (note 14).

518

The first method is nice in that complete union of the hydrogen and oxygen is guaranteed, without remnants of the unmixed gases.

A shortcoming of the method is the hazard of an explosion penetrating through the gas to the point where it begins to mix. This situation can perhaps be avoided by passing the fulminating gas ahead of the actual ignition zone through a layer of mechanical wire gauze (Davy lamp principle) where they would normally be mixed, or through some kind of porous materials, or perhaps by yet another means. If at all realizable, the first method should be used.

If the danger of explosion can only be circumvented by incomplete mixing, i.e., by delivering the oxygen separately to the ignition region but with more or less of a hydrogen admixture, and hydrogen with an admixture of oxygen, then the combustion must be accomplished by this method. Partial mixing can be accomplished by passing the gases through two tubes, one of which is more or less porous or even perforated. But even if with incomplete mixing we are not able to obviate the danger of explosion, the gases must be delivered to the combustion region separately (it is quite certain, however, that safety will be achieved with incomplete mixing). With either partial mixing or no mixing at all, the final mixing will therefore take place freely in the tube itself; experience will reveal just how profitable this will be.

To make it easier for the gases to mix in the tube, they should be injected by branching the oxygen and hydrogen tubes into a large number of very small ones, with the same, square cross section. These tubes are then intermingled so that their ends form a checkerboard pattern (note 15):

Oxygen	Hydrogen	Oxygen
Hydrogen	Oxygen	Hydrogen
Oxygen	Hydrogen	Oxygen

With this method, even though the gases are not mixed at the ignition site, they will still be rather finely stratified. It goes without saying that the heater (oven) must be made of suitable materials so that it will not set fire to the fulminating gas.

Scheme of the Heating System, Pumps, and Regulator.

519

The pumps - or what amount to pumps in their general proportions - and all of their associated lines must be solidly built, especially for large tanks, because from them will be consumed an enormous volume of gas every second. This solidity requirement even makes it desirable to do without them if possible (note 16).

But, again, this is unsuitable, because sufficient pressure is required in the tank to enable the gases to emerge into the tube, where the pressure is never very low. The pumps are of the single-cycle type, one for the hydrogen, one for the oxygen.

From the pumps, part of the gases go for combustion, the other part for heating. Both must be regulated. The heating gas is clearly pumped as a surplus quantity. It is delivered along the tubes to absorption heaters (where it is heated) contained within the tube, whence it passes along the small tubes into the heating ovens, which are contained in the tanks. From the heating ovens it is simply ejected back into the tank. The heating regulator is located near the injection orifice and consists of a baffle, which moves at right angles to the tube and its opening to make it wider or narrower. This baffle operates on pressure; should the pressure become ever so slightly greater than normal the baffle will close off the opening, and the inadmission of heat, instead of causing vaporization, will lower the temperature and pressure. The same is true in reverse; if the pressure is low, the heating is stepped up, elevating the temperature and pressure. The position of the baffle can be regulated as a function pressure in the tank by constructing its wall like the aneroid barometer. This, in any event, presents no difficulties. I feel only that installing a mixture regulator in the rocket is a good idea, but right now I find that it complicates the vehicle unnecessarily; in the actual tuning, everything should be adjusted and experimentally tested to the extent that extensive regulation will not be necessary. And if everything is in proper balance, misfortune will not result. The residual unused agent is simply vaporized. The pumps are driven by an engine (internal combustion or, better yet, a turbine, again with appropriate materials), which also operates with the fulminating gas. The accelerator of this engine will also include all necessary combustion-acceleration control.²

² The exhaust pipe of this engine should open into the tube where the pressure of the gases in the tube is such that the exhaust gases can emerge from the engine.

The Tubes

The most appropriate type of tube is shown (fig. 11) (approximately a parabaloid of revolution, except that the parabolas are not quadratic but one degree higher; in the following discussion, however, we will go over to a simple cylinder for convenience).

Its surface should be as highly polished as possible, in order to minimize drag on the escaping gases. Theory shows that with a proportionate overall decrease or increase in cross sectional area, if the gases are fed in at the same temperature and in the same quantity, only the density of the gases is varied throughout (increasing by the same factor), while all the rest - velocity, temperature, efficiency - remain unchanged.

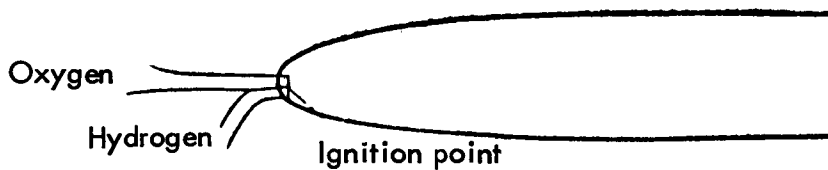

Figure 11

However, particularly narrow tubes ought not to be used, because the pumps would become quite overloaded trying to feed the gases at a proportionately increased pressure. /520

Right now, we are not able to estimate the dimensions of the tube, even approximately. Tests will be needed with tubes, and it will be necessary to develop a theory to describe the flow of gases from one volume to another (has this perhaps already been done in the theory of ideal gases?) (note 17). Inasmuch as the cross sections of the tubes need to be made roughly proportional to the amount of substance expended, each tank will have to be equipped with its own tube; for large tanks they would have to be very large. If considerable length is demanded of the tubes, they could be made from several bends, the small bends of the large tubes could serve then as large bends for the smaller tubes.

Note: In order for the liquid (or solid) gases to occupy the proper state at all times in the tanks, for it always to be possible to set the vehicle in operation without special accessories, and for the necessary temperature to be maintained in different parts of the vehicle, it is essential that the operation of the vehicle (i.e., the acceleration) not be stopped at any time during flight; instead, when this operation is not needed, it should be reduced to a minimum without being shut off altogether. The accelerator of the engine, therefore, should never be completely closed.

Instrument for Orientation

In addition to optical devices (periscopes and telescopes), permitting a full-circle field of view, it will also be necessary to carry along instruments that will indicate certain standard directions for expeditious orientation, so that we will know in which direction to transmit acceleration to the vehicle (which way to turn it). These directions are the axis of the earth and the perpendicular to the earth's ecliptic, and perhaps other directions, depending on how we execute the flight. We can fix these axes in the form of astatic gyroscopes, secured so as to render it fully possible to freely turn in all directions, i.e., more correctly, to remain stationary relative to turning of the vehicle. This could be done, for example, by allowing them to float freely in a fluid. They could be rotated by electric motors. /521

Acceleration Indicator (Mechanical Type)

The acceleration indicator is simply a tightly stretched spring balance on which a weight is hung. The spring balance will then indicate the weight of this load relative to the vehicle, i.e., the magnitude of the mechanical acceleration of the vehicle (there is no possible way of determining the gravitational acceleration inside the vehicle). After looking at this spring balance, we can then operate the accelerator of the engine accordingly. If to the spring indicator we attach a pencil and place under this pencil a moving paper tape, on the latter we will obtain a curve (actually the area bounded by it) which will serve as an indication of the total mechanical acceleration imparted to the vehicle (i.e., the sum of all imparted accelerations), or, equivalently, a record of the spent and remaining active agent (note 18).

The Complications Introduced by Atmosphere

Above all, the atmosphere will hold back the vehicle during escape and at sufficiently high velocity will heat it (see the section entitled "Temperature of a Moving Gas Relative to a Stationary Body"). In order to preclude either effect, should they become excessive, it might be possible to fit the entire vehicle within a jacket specially adapted for flight in air.

A second problem is that atmospheric pressure raises the pressure and density of the gases at the exit opening (and they cannot be exhausted so easily), which means a reduction in velocity of the emerging gases and a reduction in the efficiency. To cope with this circumstance it will be obligatory to compress the gases at the exit sufficiently that they will never be affected by atmospheric pressure, i.e., to compress the gases somewhat higher than would otherwise be necessary. To do this, however, without losing efficiency, i.e., without raising the temperature of the gases at the exit, it will be necessary to decrease the area of the exit cross section, in other words, for flight in the atmosphere to fit the exit opening with a constricting nozzle or to a function in general with a specially designed, narrower tube, which is subsequently rejected. Since the pressure in the beginning of the tube is correspondingly increased, this means that the pumps must be built to transport larger quantities of gas, to work harder in other words. In this case, the pumps must be reinforced by special bracings, which are subsequently discarded. /522

Eureka! But then, during flight in the atmosphere the pressure must also be raised inside the tanks so that they will not be crushed by the atmosphere. This is accomplished automatically, since the heating regulator is regulated according to the difference between the inside and outside pressures; it must be constructed so that the velocity of the vehicle will not affect the air pressure on the regulator. On returning to earth, the same must be repeated.

Just from what has been said so far (concerning atmospheric resistance, heating, complication of the tube), it is apparent that the sooner the escape from the atmosphere, the better. The main factor here is the first few tens of kilometers of the atmospheric thickness, since beyond this limit its density becomes negligible. Therefore, even the second method of flight must begin approximately as the first, almost perpendicular to the earth's surface, with the acceleration directed along a tangential course from the moment of takeoff.

Utilization of the Atmosphere

Over and above the harmful complications occurring in departure, namely heating of the tube, there are useful effects on the return trip, particularly in the second method of flight and in the third method of return (which will be discussed presently), namely the resistance of the atmosphere, which is helpful in this case. For the first method it plays a minor role, while for the others it may play a very large role.

Suppose that we return by the second method. We will begin describing a circle around the earth, not outside the atmosphere as had to be done in departure and as might be done on the return trip, but inside it. Then the atmosphere can be used to absorb the velocity of the vehicle, so that we do not have to expend active substance for this purpose (except, of course, that which is used to bring the vehicle into its circular path). The applicable formula, then, is the following:

$$M = me \left[1 + \left(1 - \frac{1}{\sqrt{2}} \right) \right] \sqrt{\frac{r_j}{p}} \left(1 + \frac{1}{k-1} \right) = me \left(2 - \frac{1}{\sqrt{2}} \right) \sqrt{\frac{r_j}{p}} \left(1 + \frac{1}{k-1} \right) \text{(note 19)}$$

and the economy of active agent is substantial indeed.

The third method of return to earth consists in approaching earth tangentially without consuming any of the active agent but utilizing the atmosphere to reduce the velocity and overcome the excess centrifugal force which would otherwise hurl the vehicle back from earth into empty space. The remainder of the operation is executed as in the second method.

The formula for the third method is now

$$M = me \sqrt{\frac{r_j}{p}} \left(1 + \frac{1}{k-1} \right)$$

The radical with no longer any coefficient is the square of the material economy.

523

As we will see presently, both the second (in the atmosphere) and third method of return yield very large fuel economy, i.e., we can accomplish the same flight with incomparably less expenditure of material, or with the same expenditure we can realize much longer flights (see the section entitled "Flights Inside and Outside the Solar System").

Both of these methods, however, are far from simple to realize. We will show why later (note 20).

Temperature of a Moving Gas Relative to a Stationary Body

The temperature of the gas is a function of the (mean) velocity of its molecules relative to the body we use for measurement. Consequently, if the body used to measure the temperature is moving relative to the gas it will exhibit a higher temperature than if it were at rest (relatively). It is said, for example, that meteors burn up from the "friction" of the air. They burn up because the mean velocity of the air molecules (due to the tremendous velocity of the meteor relative to earth) relative to the meteor is enormous, hence the air temperature relative to the meteor is enormous.

For this reason, it becomes hot and burns up. When the issue concerns the motion of a gas relative to a polished surface, then, since smoothness prevents us from being able to determine the motion parallel to a surface, and since the (ideally) polished surface does not resist the motion of a gas parallel to it, it must be supposed that the more highly polished the surface the more its temperature relative to the moving gas will become a function solely of the velocity component of the gas normal to the surface. In other words, if a polished surface moves at an angle through the atmosphere with respect to the direction of motion, then the smaller the angle of attack the less this surface will be heated in flight (fig. 12).

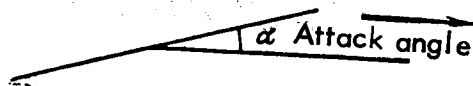

Figure 12

All this, of course, needs to be investigated experimentally from the quantitative aspect (note 21).

Heating associated with rapid motion through the air is the first complication in the second means of descent with the help of the atmosphere, as well as the third method. The second complication of these methods is the risk attending even the slightest error in control.

For the reasons enumerated above, the vehicle (that part of it which remains at the time descent commences) must be placed in a sheath, which (if it proves feasible not to burn up like a meteor) should preferably resemble a very elongated projectile, rather than an aircraft. All of its forward-facing surface angles should be small with respect to the direction of motion. This is not required for surfaces facing backwards, because a void is formed at the rear; however, this sheath (or, perhaps, not a sheath but the vehicle itself will be constructed in this form) will have to be constructed so that there will not be the slightest propensity for it to fly through the air other than nose first. Here is my conception of the vehicle cross section in highly simplified form (fig. 13). If the vehicle itself is built in this form (which would be better), the chamber and remnant active agent will occupy the entire volume.

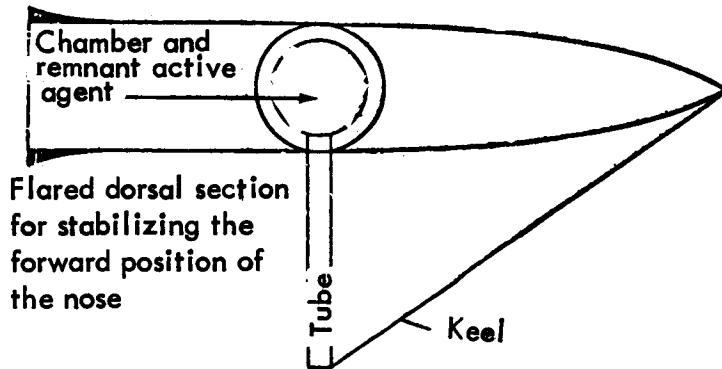

Figure 13

Almost all of the velocity loss must be completed in the very upper layers of the atmosphere, where its density is insignificant, the resistance then being correspondingly less, and where the hydrogen content will be less likely to heat the surface of the vehicle (in the theoretical analysis of the feasibility of not burning up in the atmosphere, the hydrogen composition of the upper layers must be taken into account) (note 22), since the hydrogen molecule is extremely light and the same velocity with respect to it will produce a correspondingly lower temperature. As long as possible, i.e., until almost all of the velocity has been absorbed, control should be maintained such that the vehicle is kept in the upper layers of the atmosphere, desisting from descent into the denser regions until the velocity has been reduced. Using the third method of descent, the angle of attack must first be negative in order for the centrifugal force not to hurl the vehicle away from the earth. The control must be very precise.

The slightest error in the angle of attack and the vehicle will plunge into the dense layers of the atmosphere, where neither will the vehicle be able to withstand the drag force nor the passengers be able to tolerate the deceleration, or it will simply hurtle into earth. Or it might fly upward from the atmosphere into empty space and then fall to earth at such an angle that it will be

impossible to forestall catastrophe; after all, for velocities reckoned in tens of kilometers per second, the atmospheric layer is not so thick that maneuvers can be performed in it. Finally, even with an insignificant increase in the angle of attack, the vehicle will fail at once to withstand the increased drag. For descent by the second method, it is recommended that from the very beginning the angle of attack be chosen such that it will be safely larger than necessary, but without forgetting that a large angle of attack means greater heating. If we approach the highest layers exactly tangentially, such an angle of attack will not cause the vehicle to descend much below the "surface" of the atmosphere until its velocity is safely reduced.

Control is executed by means of an elevator control device. The vehicle must be constructed so that other control foils or fins will not be needed; it should be self-stabilizing. Furthermore, the vehicle itself will contain a bulwark of stability, the gyroscope. But the latter will not be able to cope with turns that are excessively abrupt. The gyroscope must therefore be clamped at all times during descent; at no time should it be disengaged. The elevator, of course, must be constructed so that the largest rotations of which it will be capable are small.

In readying the vehicle for the atmospheric-assisted return trip, it should be contrived in some way, so as not to allow the vehicle to incandesce excessively, to cool it, making it in the form of several, sequentially ejectable casings, or to change only the penetrating portions of the nose section as they wear out, to make the surface of the vehicle of the most highly polished, yet high-melting material (quartz), or to make only the nose section of such material, and even to make of such material something akin to the forward buttresses used in bridges. In general, it seems to me, this problem is rather difficult. And experiments must be carried out in large numbers on the problem, gradually approaching velocities of 22 (for the second method) and 35 (for the third method) kilometers per second (note 23). If it is possible to eliminate burnup only at velocities which are smaller but all the same rather appreciable (say, 10 kilometers per second), then a hybrid method of descent might be used; some of the velocity is lost outside the atmosphere, and only the remaining part is liquidated by means of the atmosphere.

The Best Thermal Nonconductor; Heaters

526

As is known, the currently best known nonconductors of heat are empty layers between two very highly reflective polished surfaces. Heat conduction cannot take place through such a layer, and the transmission of thermal radiation is weak due to the inability of the surface bounding the vacuum layer to radiate and absorb radiant heat. The thickness of the empty layer in this case, obviously, does not play any role, since we are concerned here with radiation. This means that the very existence of the empty layer between two polished surfaces presents a substantial obstruction for the transmission of radiant heat. If, however, we insert into this empty layer between two surfaces, parallel to it, a certain number of thin polished plates, we obtain as a result several, rather than one, such empty layers. Consequently, we can acquire in a small thickness a layer that represents a tremendous obstruction to heat. The use of such an arrangement on my vehicle is all the more suitable in that it can

prove to be exceedingly light (the plates can be made as thin as we like, as long as they do not become transparent), and the void between is extremely easy to construct, because its size amounts to next to nothing.

Thermal nonconductors are needed throughout my rocket: to heat the passenger chamber; to separate the hydrogen and oxygen, which will be at very different temperatures; to heat (or to prevent from heating), in general, to insulate all tanks from the temperature effects of interplanetary space and solar radiation. Heaters will also be needed on the tube, so that it will not dissipate heat into space as the hot gases move through it. In general, thermal conductors will be required in many places, because such disparate temperatures must exist throughout the vehicle: in the oxygen and hydrogen tanks, chamber, gases in the tube, and the outside interplanetary temperature. Moreover, heaters will have to be used as part of the equipment for absorbing solar energy (more on this below).

A Device for Utilizing Solar Energy
(For the Decomposition of Water)

The construction of the device is evident from a schematic cross section (fig. 14). A parabolic reflector is aimed with its axis toward the sun. The sun's rays are reflected and converge at the focus, where they pass through an aperture into the heater (see the section entitled "The Best Thermal Nonconductor"), which is placed so as to prevent the receptacle located within it from dissipating the heat nonproductively.

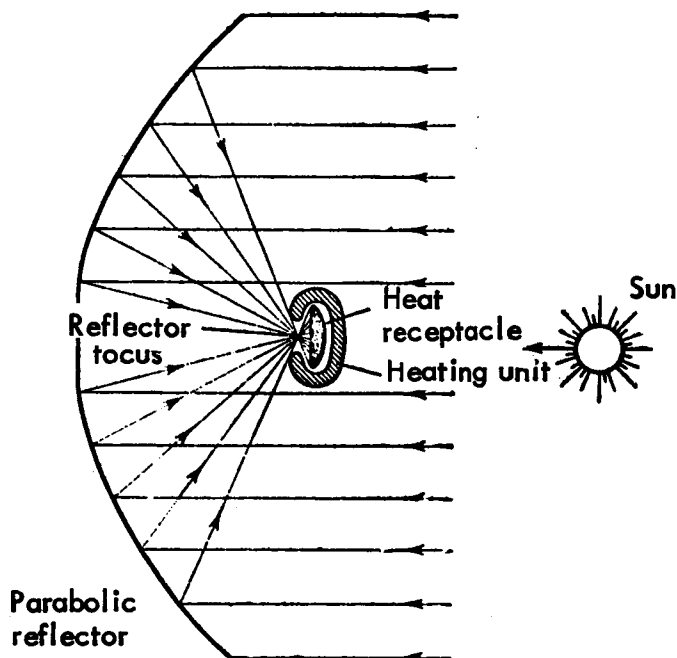

Figure 14

This is a very suitable arrangement for any device to utilize solar radiation for the development of high temperatures, which we can achieve in the receptacle by means of concentrated solar illumination, without the nonproductive loss of heat. Now, we have two possible arrangements of receptacles for the decomposition of water: In the first case, we require a very hot mixture of hydrogen and oxygen; then the receptacle is simply a high-melting, gas-impermeable tube, whose temperature, maintained by concentrated solar radiation, is such that the water is decomposed and we obtained the required products; in the second case, we wish to obtain hydrogen and oxygen separately in the cold state. Here is a diagram of the appropriate arrangement (fig. 15).

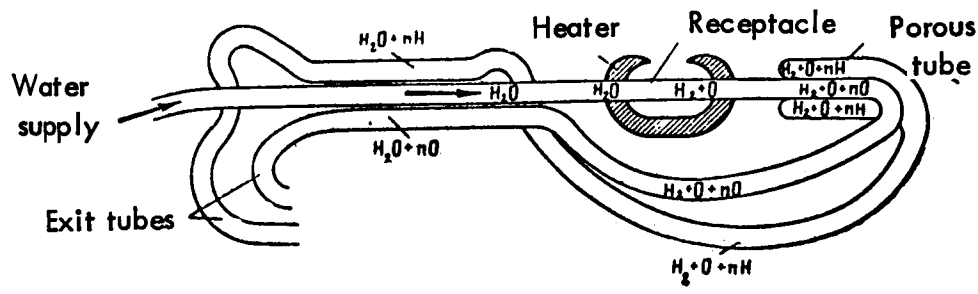

Figure 15

Decomposition is initiated the same as in the first case in the very hot receptacle-tube system.

The further (incomplete or partial) separation of oxygen from hydrogen takes place by the familiar technique based on the different diffusion rates of oxygen and hydrogen. From the receptacle the gasses pass into a tube with porous walls, which is encased in another tube (without porous walls). The gases diffuse through the walls of the porous tube and, because of the different diffusion rates, an excess of oxygen is obtained in the inner tube, of hydrogen in the outer tube; also, the contents of both tubes flow countercurrent to the water feeding into the receptacle, imparting to the water all of their heat above normal (this is possible because the specific heat of H_2O is higher than that of $H_2 + O$). In the exit tubes, as a result, we obtain water, which is recirculated, plus oxygen in one and hydrogen in the other. The fulminating gas extracted by decomposition can be used in an internal combustion engine. The power of solar radiation - about three horsepower per square meter of cross section - promotes the very profitable application of this machinery.

The entire system of tubes in these devices must, of course, be very painstakingly fitted with heaters (see "The Best Thermal Nonconductor").

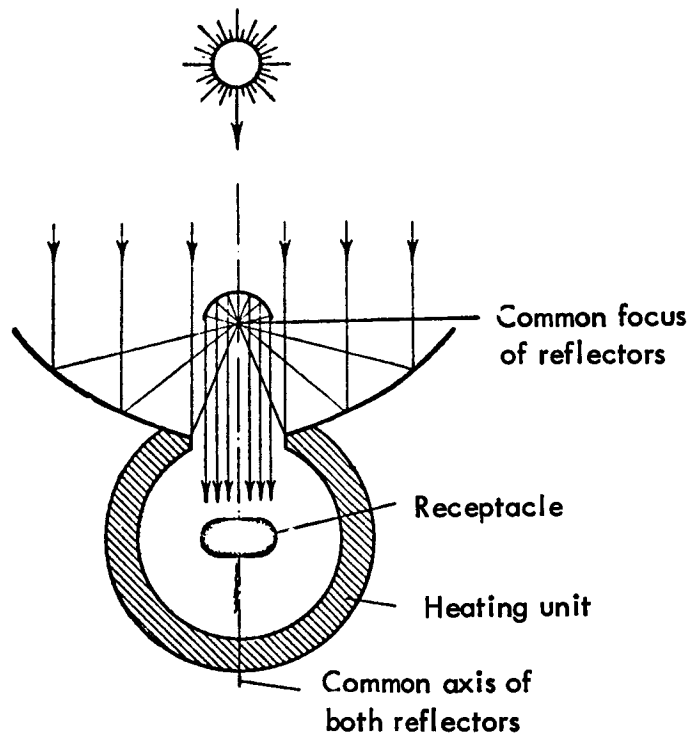

Figure 16. An Alternate Arrangement of Reflector and Heat Receptacle

Reflectors

The parabolic reflector can be of two types: a paraboloid of revolution (fig. 17) or the surface of a right cylinder, the basic cross section of which is a parabola (fig. 18).



Figure 17

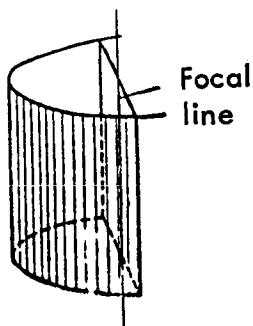

Figure 18

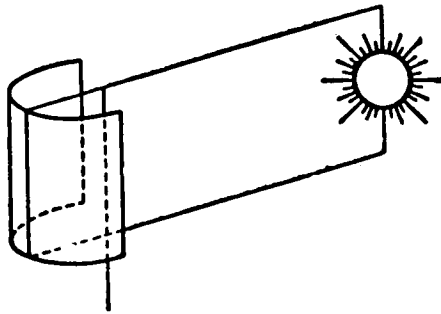

Figure 19

In the first instance, the focus of the reflector is a point, in the second it is a line parallel to the generatrices.

The one outstanding advantage of the first type of reflector is its greater concentration of rays (square-law) over the second type of reflector (linear). It has the following drawbacks:

1. Its surface is not expandable, so that it is very difficult to fabricate and is not readily portable, since it is poorly and imperfectly put together and stored, whereas the cylindrical surface can be folded up as much as we like.

2. (With reference to use on a rocket) in order to tolerate any acceleration imparted by the application of force to any part of it, the reflector must be made strong enough; the greater the potential acceleration the stronger it must be, i.e., it will have to be correspondingly heavy, whereas if an acceleration is imparted to the second type of reflector by a thrust parallel to its (focal) axis, then no matter how thin and light it is, it will sustain the same acceleration as a wire of the same material, the same length, stretched in the same direction. /530

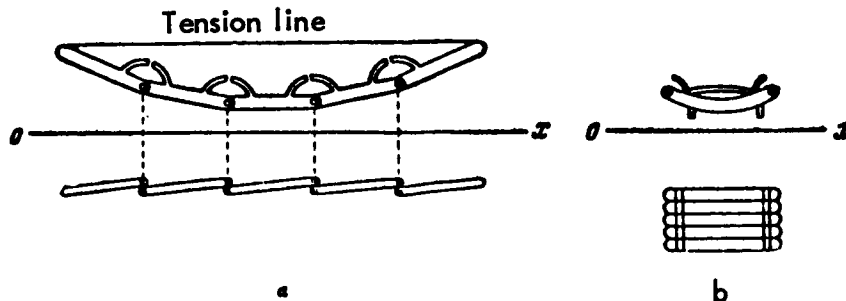

Figure 20. Collapsible Frame for the Second Type of Reflector:

a) in expanded form; b) in collapsed form

3. (Also important with reference to rockets) the first type of reflector, in order for the rays to intersect at its focus, must be accurately positioned in a certain direction relative to the sun. For the second type of reflector

fluctuations in one plane are permissible, namely so that the sun will be somewhere in its axial plane.

With these same limitations, only the amount of energy trapped by the reflector is affected by its rotation; on the vehicle, then, the second type of reflector, even though its axis must always be parallel to that of the vehicle so that it can be fairly delicate and still withstand acceleration, can always be used (only when the axis of the vehicle is pointed directly at the sun will their effectiveness fall to zero).

The one shortcoming of the second type of reflector (see above) does not play a major role, because temperatures higher than any material can withstand are not likely to be reached, and with reflectors of the second type we can strive for extremely high temperatures.

The thickness of the reflector itself has not been included here in my analysis, since for a vehicle the reflectors will be made very thin.

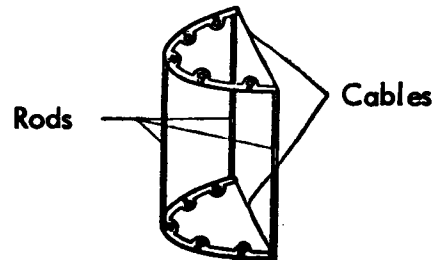

Figure 21. General View of the Overall Frame

Utilization of Solar Radiation in the Vehicle

In the vehicle (rocket), we can utilize solar radiation for preheating the oxygen and hydrogen prior to their delivery to the main tube. This will impart to them greater injection velocities, hence greater efficiency. To make use of solar radiation on the rocket, it will be necessary for the reflectors to encompass very large areas. These reflectors (second type, with collapsible frame) should be made of ultrathin sheets of some metal (nickel, for instance), which will reflect the largest possible percentage of the available power from 531 the sun's radiation. Inasmuch as the reflectors themselves will be very light, their frames can be correspondingly light. I am not able, due to unavailability of the necessary data, to estimate the lightweight characteristics of these reflectors, so I cannot evaluate their applicability on the rocket. Probably, their application will be advantageous only where considerable acceleration is not demanded, i.e., for example, in the second phase of flights from earth by the second method, in the first phase of the return trip by the second method, or in flights within the solar system by the second method (see "Theory of Flights"). If we succeed in building a reactive vehicle that operates from the emission of cathode rays, then only from the sun can it derive a sufficient quantity of energy and convert it from thermal into electrical energy.

Potential Uses of Reflectors

Let us suppose that we have been able to manufacture delicate and light-weight portable (plane) reflectors! We will make the reflectors very large and in large quantities (I am sure that a dessiatine (Russian unit of land measure equal to 2.7 acres) of reflector will not weigh more than a few dozen poods (36 pounds; hence an order of magnitude areal density of 10^{-3} lb/ft²)). We send them up with rockets and put them in the state of earth satellites. There we expand them. We combine them in ever larger frames (note 24). We seek to control them (change their direction) in same way, for example, by placing small reactive devices at the nodes of their frames, actuating these devices by means of electricity from the central chamber.

If these reflectors are reckoned in dessiatines, a series of them could be used to illuminate a metropolis. But if we were to spend enormous sums on this project, producing the reflectors in tremendous quantities, and positioning them around the earth so that they (almost) always are accessible to solar radiation, they could be used to heat part of the earth's surface, warming the wastelands and rendering them fruitful. It may even happen that, by using the enormous quantities of heat and energy that the reflectors develop, they could be used to make other planets habitable for man, eliminating hazardous elements, permitting the growth of essential nutrients, and providing heat. The same reflectors, used as shields, could be used for cooling where necessary, by shielding from the sun. Finally, by concentrating solar radiation on a certain portion of the earth from several times the area, that region could be incinerated. In general, with the kind of enormous energies that reflectors can provide, our most fantastic dreams could become reality. For flight in particular, they may have the added value that by aiming a broad beam of light at the vehicle, we can communicate to it a larger amount of energy than could be obtained from the sun. Similarly, we could also sound a signal in the solar system. /532

(Reflectors could also be used to reflect waves from wireless telegraph stations to send them wherever necessary.)

Theory of Flights

To make a stopover at some other planet, the ratio M/m for flight and return to earth must be multiplied by the same ratio for this planet. It would be more advantageous, therefore, not to land the entire vehicle on the planet but to send a satellite (around the planet), in fact just that part of the vehicle that will be needed for landing on the planet and returning to the vehicle. In order for the main vehicle to remain visible from large distances, it will have to be equipped with extremely large plates (of paper), exposed in different directions, so that they will be visible from any side; their surface should have a dull luster and they should have no weight, since no particular durability will be required of them (note 25).

Regardless of how the flight from earth is made, it will be advantageous to have bases with low gravitational potentials, for example, on man-made satellites of the moon or on the moon itself. On moon bases, if water exists there,

solar radiation could be used to produce the active agent. On man-made satellite bases it would be necessary to store reserves of active agent, instruments, equipment, food supplies.

Bases, in general, could provide incomparably greater freedom of operation (note 26). Emergence from the chamber of the vehicle, of course (except on planets whose atmosphere can be breathed), can be made in outfits more or less resembling diver's suits, with a stored air supply. All bases will have to be made in the form of a chamber if we wish to take off the diver's suits (note 27).

Flights Inside and Outside the Solar System

The potential energy of the sun's gravity on earth corresponds to approximately 40 km/sec (note 28). But we already have 27 km/sec in the earth's velocity in its orbit; we only need an additional 13 km/sec to acquire the velocity needed for the flight and return to earth (35 km/sec), in order to be able not only to fly away from earth and back again, but also to move freely 533 inside the solar system and even to fly away from it altogether. The ratio M/m for this only needs to be raised to the power $(13 + 35)/35$, which is about $4/3$. This is not too frightening. In order to move about in the solar system from one place to another, two methods of flight are also possible, by complete analogy with the arguments relative to flight from the earth (straight or spiral trajectories). The second method has the advantage here that, after flying away from earth, we are already in the second phase; we are no longer confronted with its shortcoming, namely the considerable difficulty in maintaining control in the flight from earth, when it is necessary to operate quickly and with precision; on the other hand, the second method requires much more time (note 29). Consequently, I believe that if the vehicle is to function solely on the active agent, the first method will be more suitable, but if reflectors are used and they cannot provide considerable acceleration in comparison with the sun, it will be necessary to fly by the second method.

But there is a happy combination of both: to wait until the earth moves around the sun to a point nearest the prospective destination, then to head there.

In all flights, of course, the method and direction of flight will have to be such that the motion of the vehicle relative to the sun will be in the same direction as the motion of the earth (or base), just as the flight from earth was made in the direction of its rotation about its own axis. This means that solar gravitation will only have to be slightly reckoned with.

Utilization of the Relative Motion of Celestial Bodies

Use of a satellite for flight in the solar system when it is required to gather velocity, and the return from this flight when it is required to absorb velocity.- Figure 22 shows a line of flight equally suitable for flight from a planet and for return (under the conditions specified in the heading). Considering the relative size of the satellite and its distance, this method can 534 provide or take away velocity in an amount equal to as much as twice its velocity.

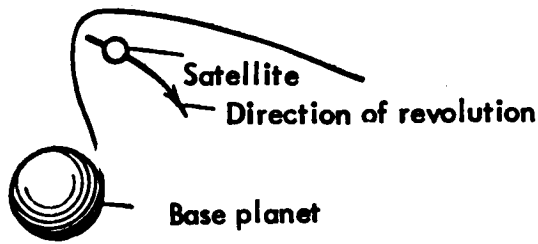

Figure 22

Utilization of Bodies Moving Toward or Away from One Another. - It is readily perceived that if we describe a curve about two bodies approaching one another (fig. 23), the velocity of the vehicle will be increased until we are able to force it to break away into outer space, even flying near their surface. If the two heavenly bodies are moving apart, on the other hand, the velocity will be decreased.



Figure 23

The Electric Gun

If, for some reason, the convenience afforded by motion in interplanetary space can justify the very large cost, it will be necessary to build an electric gun, the only device that will provide the necessary velocity, and if not all that is needed for escape, at least part of it. Here is its construction (fig. 24).

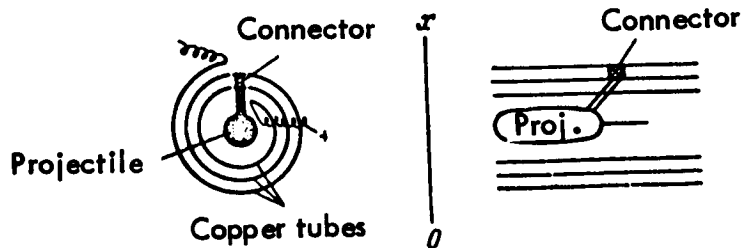

Figure 24

The body of the gun consists of several (many) copper tubes, one inside the other and mutually insulated, with a slit running their entire length. The innermost is connected with one terminal of the electrical source, the outermost with the other terminal; a projectile of soft iron moves inside the gun. 535 The projectile is joined to a connector, which makes the section of these tubes into a helix, along which current can pass. Since the connector is situated somewhat ahead of the projectile, the current in the helix attracts the projectile and compels it to move, the connector along with it, the projectile never overtaking the latter. That's all there is to it. It must be borne in mind that at the tremendous velocities and distances required, no contacts (connector) will withstand friction. This means that the passage of current must be realized without contacts, instead indirectly, by means of high-voltage arcs. In order for these arcs not to damage the connector in a short time, a lower voltage will be required, and to cause less trouble in general, the guns must be evacuated of their atmosphere, but to just that degree of rarefaction that the arcs - today a Giessler tube, perhaps later cathode rays - will be exactly what is required. This can probably be effected by proper alignment and design of the insulators, not permitting the arcs or rays any accessible opening other than necessary. Evacuation of the atmosphere is still necessary to permit freer motion of the projectile; at the enormous velocities developed, this is extremely important. And, in addition to contact between the connector and gun, it will be necessary to find and eliminate any contact between moving and stationary parts in general, for the same reasons. If the projectile tends to remain in the midline of the channel of its own accord, the arrangement will be self-adjusting. If, however, this is not the case, it must be aligned by some electromagnetic means (note 30).

If the projectile is the vehicle itself, carrying passengers, then the whole affair will require a great many years and a tremendous amount of energy. A more practicable arrangement of the gun is shown in sectional view (fig. 25).

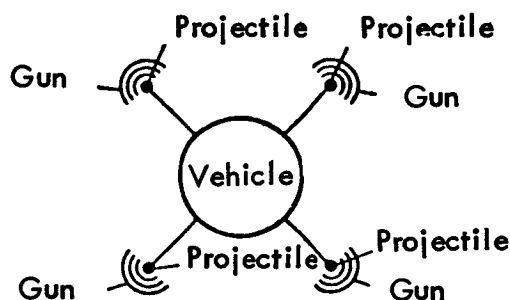

Figure 25

The vehicle is joined with the projectiles of several guns through slits in the latter. Each projectile in this case consists of several projectiles in series, which are connected in a unit form (fig. 26) by some nonmagnetic 536 material, so as to reduce drag from unavoidable residues of atmosphere.



Figure 26

If the projectiles themselves are not inclined to follow the midline of the channel, but press toward the walls, then their position can be regulated by regulating the position of the vehicle, which, it seems to me, is not difficult to cope with by electromagnetic means. It goes without saying that the entire gun must have perfect precision. How best to construct it, I do not have the data to say; either it should be built on the flatlands or allowed to float on the ocean.

Such a gun, no matter how it is realized, by imparting a considerable initial velocity to the vehicle, will relieve much of the concern about... (note 31) ... the amount of active agent consumed. It must be remembered, however, that every <unneeded> meter per second does not increase the active agent additively, it multiplies it.

So, if we could fly out there by means of a gun and return with the aid of the atmosphere, then, without carrying particularly large amounts of active agent on board the vehicle, we could carve our initials in the universe.

Yu. V. Kondratyuk first became concerned with the problems of interplanetary communication, according to his own attestation, in 1916 (see the author's preface to his book, Conquest of Interplanetary Space (Kondratyuk, ref. 2; also page 57 of the present collection)). Clearly, by the beginning of 1917 he had written the first version of the manuscript, in which he treated such problems as the derivation of an equation for rocket flight, construction of the spaceship, conditions for flight within the solar system, the creation of interplanetary transfer bases, the effects of atmosphere on the flight of a cosmic flying machine, the utilization of solar energy, and others.

This version was in the form of rough copy and was not intended for publication. Later on, continuing to work on the manuscript, Kondratyuk somewhat expanded and augmented it. Besides purely editorial modifications, he wrote new sections to it, such as "On Techniques for Increasing the Endurance of the Human Body with Respect to Appreciable Mechanical Accelerations." "Utilization of the Relative Motion of Celestial Bodies," etc.

The outcome of this was the second version of the manuscript, which in the author's opinion was ready to stand trial before the reading public, as evinced by the rather enigmatic title which Kondratyuk appended to it: "To Whomsoever Will Read in Order to Build." In 1938, when he sent his scientific archives to B. N. Vorob'ev, Kondratyuk dated this manuscript 1918-1919, but this date is in need of refinement. This version of the manuscript is also the one included in the present collection.

The pages of the manuscript contain later additions and corrections, obviously made at different times. The latest additions incorporated by Kondratyuk directly into the text of the manuscript are enclosed in angle brackets. The remaining changes and additions are given below.

Note 1, page 15. The author originally had written at this point: "about 35 kilometers per second." However, he later added the following in the margins of the manuscript: "Whence this figure was obtained, I myself fail to understand, for now I would say 11, rather than 35, of course it is 11." Accordingly, we have corrected the figure in this phrase and throughout the rest of the 658 text. It is important to note that the precise value of the second escape velocity is equal to 11.189 km/sec.

Note 2, page 18. The dimensions are not correct; they should be cm^2/sec^2 (or erg/g).

Note 3, page 18. In this and subsequent equations, the author implies by r the incremented radius of the earth, and the acceleration in the field of gravity $j = \text{const}$.

Note 4, page 21. Kondratyuk later made one additional remark: "In flight by the second method, it should be executed in line with the earth's rotation (as should the landing), in order to utilize, rather than to incur harm by the considerable velocity of the earth's rotation."

Note 5, page 22. This is apparently a misprint in the manuscript; it should be 100, rather than 1000, m/sec².

Note 6, page 24. Kondratyuk later added another conceivable principle for the construction of reactive devices:

"3. Reaction from the repulsion by electrical discharges of material particles of nonmolecular dimensions, for example, graphite powder or a finely pulverized conducting fluid. - It is readily calculated that the velocity of such particles with a large (but fully practicable) potential difference could be made exceedingly high - greater than the molecular velocity of an intensely heated gas (figure 1).

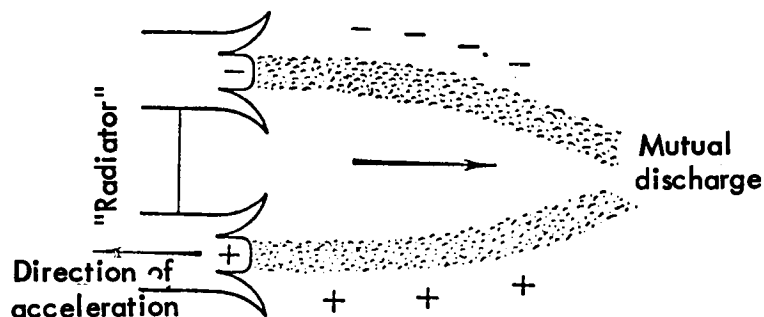

Figure 1

"Very concerted attention should be devoted to such a method. It would not be suitable, of course, until the vehicle reached atmosphere-free space."

"A second variant: A positively charged particle tends from plus to minus and, coming in contact with the latter, loses its charge, continuing on in its flight" (figure 2).

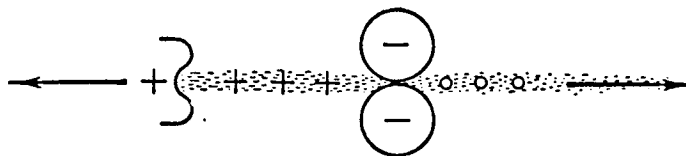

Figure 2

Note 7, page 24. Here the author indicates the need, first of all, to have a series of several expendable containers of different sizes for the fuels, second, to use up the fuel at first from the larger tanks, changing over gradually to smaller tanks, third, to recognize the fact that the proportion by weight of the tanks should be constant with respect to the weight, essentially, of the last state of the rocket, because after the tanks are exhausted, they are aborted. These were unquestionably extremely advanced concepts for the time, on the part of the author. 659

Note 8, page 24. Of course, it is impossible to store liquid oxygen and liquid hydrogen in one tank.

Note 9, page 25. Later, Kondratyuk wrote: "(This is erroneous. For the sphere it turns out to be $2/3$, for the cylinder $1/2$)."

Note 10, page 26. After the words "astatic gyroscope," Kondratyuk later made the following footnote: "The biaxial astatic gyroscope definitely cannot perform the functions that I have ascribed to it herein; a nonastatic gyroscope may be suitable, or it may be necessary to replace the gyroscope altogether with other accessories (for example, to navigate by the sun. Its illuminating power could provide a tool for automation)."

Note 11, page 28. After the heading "The Biaxial Astatic Gyroscope," Kondratyuk wrote: "(please forgive the title)." Later on, he placed this entire section, right up to the section entitled "The Chamber," in doubt. The following footnote was added to the manuscript: "See the note on page 43a" (note 10, above).

Note 12, page 30. This concept, judging from the American literature, is realized in the Apollo Project.

Note 13, page 30. The idea of keeping the fulminating gas in the tanks in solid form is without physical basis, since even if the fulminating gas could be instantly ignited and solidified, it would be impossible to be certain of a homogeneous system corresponding to the composition of the fulminating gas.

Note 14, page 31. The only possible approach is to feed the heated hydrogen and oxygen fuel components into the combustion chamber separately; the other two methods of combustion indicated by the author would not guarantee the explosion-free safety of the system.

Note 15, page 31. Kondratyuk subsequently proposed still another variant of the tube arrangement. After the words "form a checkerboard pattern," he appended a footnote: "Or, better and simpler, in tiers:"

Oxygen
Hydrogen
Oxygen
Hydrogen
Oxygen

Note 16, page 32. Kondratyuk later made the following addition here: "The pumps can also be made piston-free, by the following scheme: Liquid oxygen (Hydrogen) is forced by the pressure of the gases from the tank into a chamber of smaller dimensions but of sturdier construction, which is then disconnected from the tank, and from there the pressure of the gases again, but this time more strongly, forces the liquid oxygen into the combustion region."

Note 17, page 33. It is important to note that, at the time the article was written, analytical methods had already been developed in application to the Laval nozzle.

Note 18, page 34. Later, after the words "active agent," Kondratyuk added: "Another indicator of acceleration might be the following: A fluid is allowed to flow under its own inertia from one vessel into another via a narrow tube (so that the inertial resistance of the fluid will be very small in comparison with the friction resistance). The flow velocity will be an indicator of the mechanical acceleration magnitude, the amount of fluid that runs out will correspond to the quantity of spent active agent." /660

Note 19, page 35. From this point on in the manuscript, apparently, the expression in parantheses in the exponent written previously, $\left(1 + \frac{1}{k-1}\right)$, is not written, in the interest of brevity. We have rendered the equations complete.

Note 20, page 36. Kondratyuk was subsequently inclined to doubt the reasibility of utilizing the atmosphere as a cushion for the velocity of the vehicle. After the words "We will show why later," he wrote: "It looks as if they are altogether impossible, in that the vehicle represents a falling star."

Note 21, page 36. Later, Kondratyuk appended the following to this sentence: "It turns out that, as far as molecules are concerned, there is no such thing as a polished surface."

Note 22, page 37. The author's supposition as to the hydrogen content of the upper atmospheric layers has not been borne out by present-day research, although recently a thin hydrogen cloud has been discovered at an extreme altitude.

Note 23, page 38. The cited numerical values are incorrect, inasmuch as Kondratyuk began with much too high a value for the second escape velocity (see note 1, above).

Note 24, page 44. Later, after the words "larger frames," Kondratyuk entered the footnote: "Most likely, the best frames are made of thin-walled tubes filled with a gas with a certain expansibility."

Note 25, page 44. Kondratyuk later proposed still another method for enhancing the visibility of the satellite vehicle; after the phrase "required of them," he made the addition: "Or, more simply, a large bubble of some light, silky material, the shape of which is maintained by a flexible wire-mesh skeleton; the bubble, of course, is collapsible."

Note 26, page 45. Kondratyuk later gives here a calculation of the amount of active agent necessary for flight: "Here is a calculation of the amount of active agent that is necessary for flight from the earth and back again (by the first method), if bases are employed.

"In order to go from the satellite (base) state to the state of zero motion in the return to earth by the first method, it will be necessary to absorb a velocity of about 7.5 km/sec, for which the amount of active agent required is about $\sqrt[3]{55 - 1}$ (see page 13) (page 18 of the present collection), since all that is needed for going and returning is 22 km/sec = approx. $3 \times 7.5 =$ approx. $3.8 - 1 = 2.8$ m. This quantity, then, must be available on the base. In order to go from the earth satellite state to the state of a free planetoid and back, it will be necessary to develop and reabsorb 3 km/sec, or a total of about 6 km/sec, for which about $3m - 1m = 2$ m active agent will be needed. Consequently, a total of about $2 + 2.8 + 1 = 5.8$ m will be necessary to arrive at the state of an earth satellite, for which is required a vehicle weighing $5.8 \text{ m} \times 3.8 =$ a total of about 22 m, instead of 55, which is a considerable amelioration."

Note 27, page 45. Later, after this paragraph, the author added the following:

"It is advisable to proceed as follows: first, to send out from earth a base with supplies but without personnel, such that it will automatically be made into an earth satellite, then to send up a vehicle with people; after flying to the base, they will pick up any necessities and continue the flight, the base continuing to circle the earth. On the return flight, provisions are again picked up on the base and the return to earth completed. Such a method is appropriate in that, by sending ahead the main bulk of the load without people, we are not held back by limited acceleration and could even utilize the cannon principle.

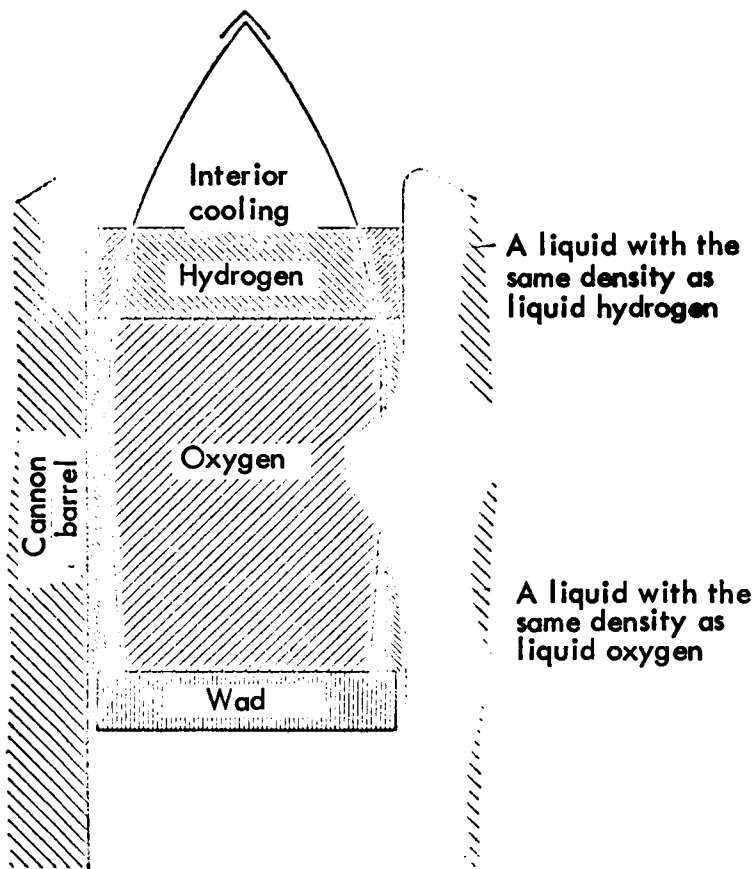

Figure 3. Construction of the Active Agent Transport Vehicle.

661

"With such a construction (the vehicle is just slightly narrower than the bore and the space between is filled with fluids), the walls of the vehicle need extra strength only to the extent that they will not be crumpled from their own weight when fired. The hydraulic pressure will not be destructive. Here we have a cross section of the vehicle (fig. 4).

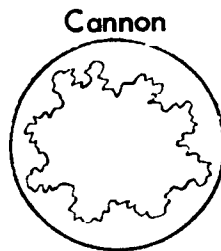

Figure 4

In order for the walls not to be crumpled during firing, the vehicle chamber should not break communication (break continuity) with the space between the walls during its motion in the bore of the cannon, or the walls of the vehicle should be made so they are capable of changing its volume.

"In order not to have to build an unreasonably large cannon, it would be better not to transport active agent in one vehicle, but in machine-gun fashion from several or even many vehicles, interconnected by cable (quartz). The cable should have a checking mechanism, so as to provide a certain tension (absorb energy), but without permitting it to spring back. In the head of each vehicle should be an attachment for automatically steering it in the direction of maximum illuminating power. The transport should be sent up at sunrise at an inclination with respect to the east; on escaping the atmosphere, the vehicle automatically turns toward the sun, i.e., aligns its axis parallel to the earth's surface (eastward) and, like a rocket, having attained sufficient velocity in this direction, enters into the satellite phase. Some of the vehicles should contain active agent, while another, smaller group should be for recognition signals that will be visible from afar. Besides large surfaces or paper and silk balloons, the signal could be made in the form of a large electric lamp or other powerful source of illumination (a special device capable of withstanding the acceleration sustained in firing), which would derive its energy from the sun through the medium of mirrors. Its advantage would be its ability to shine at night, provided the daylight energy could be stored up automatically. /662

"It would be best to place the cannon in water so that it would float. This would greatly diminish the ancillary equipment needed for the cannon, would simplify the cannon itself since it would not need to bear its own weight, and would facilitate direction-control of the cannon. Furthermore, the water pressure at considerable depths would reduce the need for strength on the part of the cannon, because it would be acting in a direction opposite to the gas pressure. Note: If the breaking strength is considered equal to 100 kg/mm^2 , then a cannon whose wall thickness was equal to the radius of the bore could sustain a pressure of 10,000 atm; it would be more sensible, in terms of quantity of material, not to permit a pressure of more than 2500 atm.

"When the completed base is equipped to utilize solar energy, it would be better not to send the active agent there in the form of separate oxygen and hydrogen, but simply as water, decomposing it when it arrives there."

Note 28, page 45. The numerical values quoted by the author here and below are inaccurate. Moreover, it should be realized in the present instance that Kondratyuk started with much too high a value for the second escape velocity (see note 1, above).

Note 29, page 45. Later, after the words "requires much more time," Kondratyuk wrote: "the same as the first; I did not include the dimensions of the solar system in the calculation; here acceleration only needs to be applied once."

Note 30, page 47. After the words "electromagnetic means," Kondratyuk later made the following annotation:

"P.S. All of this (i.e., an electric gun that would be capable of supplying a velocity of 10 versts/sec (approx. km/sec)) now seems impracticable to me."

Note 31, page 48. Here, after the words "will relieve much of the concern about," which came at the end of a page in the manuscript, one or two lines are missing.

Author's Preface

The major portion of the present work was written in 1916, after which it was supplemented and radically revised three times. The author hopes that he has succeeded in presenting the problem of conquering the solar system not so much in the form of theoretical principles, leaving their development and practical application to the science and technology of the future, as in the form of a plan of attack, which, even if not detailed, is outlined with concrete figures that are fully realizable today with current technology once we have performed experiments not presenting any particular difficulties. And this realization, from the first preliminary experiments beginning and ending with flights to the moon, would require, to the extent that this can be adduced beforehand, less material media than the equipment for several of our largest warships.

As to the existence of Engineer Tsiolkovskiy's paper on the same subject, the author later became aware of the work and has only recently had the opportunity to familiarize himself with a portion of the article entitled "The Investigation of Cosmic Space by Reactive Devices," published in the journal Vestnik Vozdukhoplavaniya (Aeronautics Bulletin) for 1911, and I am convinced of Engineer Tsiolkovskiy's prerogative in the resolution of many of the fundamental issues. However, paragraphs that clearly no longer represent new ideas have not been rejected from the cited article, on the one hand not to disrupt the integral unity of the presentation and in order not to refer the interested reader to the now very rare and difficult to locate issues of Vestnik Vozdukhoplavaniya, on the other hand so that the theoretical postulates and formulas themselves, just used in a slightly different way, will occasionally put the entire problem in a new light. Similarly, the author has also not had the opportunity to become acquainted either with the foreign literature on this problem or even with the second part of Engineer Tsiolkovskiy's article, which was published in the 1912 issue of the same journal.

Many of the formulas and almost all of the numerical data cited in this work are given with simplifications and rounding off, on occasion even rather coarsely; the reason for this is that we are still lacking the experimental material needed for a detailed treatment of the problem, so that there is no point in our bothering with hundredths as long as we can still be sure of accuracy to tenths; the sole objective of some of the computations in the present work is to give a notion as to the order of magnitude of the physical quantities with which we will have to deal, and as to the general nature of their variation, since their exact values cannot possibly be computed until suitable experimental investigations have been performed. For similar reasons, there are no construction plans or drawings; the general design principles can be readily enunciated, but we cannot develop the particulars: therefore, any drawing purporting to contain specific design features would hinder rather than aid the scientific concept. /538

In view of the relative newness of the subject, the author has been compelled to introduce quite a few of his own terms, which are replaced almost throughout, for the sake of brevity, by symbol designations, the application of

which is such that the very same symbols denoting numerical values of physical quantities in the formulas and computations replace the corresponding conventional physical or special terms of the present work in the text of the latter. To facilitate matters for the reader, a separate list of all symbol designations used repeatedly in different parts of the work is given at the end of the article. Wherever special notation is not given, the symbols denote the physical quantities expressed in absolute (c.g.s.) units.

June 1925

Yu. Kondratyuk

Second Author's Preface

I am going to discuss a fundamental general problem of this work, which is completely untouched in the original presentation, i.e., the problem of the expected consequences for mankind when it emerges into interplanetary space.

Prof. Tsiolkovskiy, the pioneer researcher in this field, views its significance in the fact that mankind will be able to colonize the vast reaches of the solar system and, when the sun cools, to travel by rockets for the population of still uncooled worlds.

Such possibilities, of course, are not by any means excluded, but all this is the prognostication for a very distant future, some of it extremely distant. There is no doubt that for a long time yet the investment of resources and improvement of living conditions on our planet will be more profitable than colonization beyond it; it should not be forgotten that only a very small part of the total surface of our planet has been populated and exploited. We will examine the problem of man's departure into interplanetary space from a more "present-day" point of view: What specifically can we expect in the near future, at most ten years, after the first flight from earth? /539

Without dwelling on more or less groundless fantasies, we can expect the following:

- 1) An incontrovertible enormous enrichment of our scientific knowledge with corresponding ramifications in technology.
- 2) The possible, more or less probable, although not certain, enrichment of our technology with valuable materials which might be found on other bodies in the solar system and which are absent or are extremely rare on the earth's surface.
- 3) Other possible riches from the solar system, which we are partially unable to foresee right now and which may or may not exist, as, for example, the results of intercourse with the presumed organic world of Mars.
- 4) The unquestionable possibility for man to acquire resources which he can use to radically improve the conditions of existence on earth, to exercise reclamation on a grandiose scale, realizing undertakings in the not too distant future of such magnitude as, for example, altering the climate of entire continents.

I am speaking, of course, of nothing other than utilization of the untapped stores or energy in solar radiation, which is so difficult under conditions present on the earth's surface, which make it less profitable than the exploitation of fuels, water, and wind and which, on the other hand, will be immeasurably more profitable in outer space, where there is no atmosphere or apparent gravity. It is the possibility of beginning in the immediate future to improve the economy of our planet that should be regarded as the chief aspect of tremendous importance to us in mastering the outer space of the solar system.

Reflecting on the impressive achievements of science and technology in recent years and, in spite of ourselves, wondering why the problem of interplanetary travel has not been solved in practice before now, the problem, essentially, in comparison with other advances, is not so difficult if approached scientifically and without the eyes prematurely widened in astonishment and fear, nor is it so grandiose in terms of the technological means required; at the same time, however, it is of such vast significance that it will only fail to come to fruition through lack of courage and initiative on the one hand, and through failure to grasp the practical importance of the problem on the other hand. If the cost of this task, given the same difficulty, were expressed more explicitly in dollars, so as not to be overwhelmed by its extraordinary aspect, the Americans would truly have already licked the problem, instead of, like the Germans, just having conducted some very preliminary experiments directed, insofar as one may judge from our newspaper reports, along not altogether proper lines of attack.

In 1921, I arrived at a very unanticipated solution to the problem of 540 setting up a continuous line of communication from earth into space and back again, the materialization of which requires only the use of a rocket such as the one discussed in this book; in 1926, I arrived at an analogous solution of the problem of a rocket developing the initial 1500 to 2000 m/sec of its escape velocity without the expenditure of charge and, at the same time, without a colossal artillery cannon or superpowerful engines, or for that matter any kind of giant apparatus. The indicated chapters are not included in the present book; they are already too near the working project of mastering outer space, too near to be published, not knowing how and by whom these data will be used.

In conclusion, I must express by profound gratitude to Prof. V. P. Vetchinkin, the editor of the present work and its first critic.

October 1928

Yu. Kondratyuk

I. Facts Concerning the Rocket.

Principal Notation

A mechanical definition of the rocket as a reactive device is the following: "A vehicle which, ejecting particles of its own mass with a certain velocity, itself develops a velocity in the opposite direction due to their effect." We will adopt the following terms and notation with respect to rockets:

- M Mass of the rocket at a given instant;
- M_0 Initial mass of the rocket;
- M_f Mass of the rocket on completion of its operation as such; the "final mass";
- M_{i_0} Mass of the rocket at the instant it passes the initial point of a given segment (i) of its trajectory;
- M_{i_f} Mass of the rocket at the instant it passes the final point of a given segment (i) of its trajectory.

The "exhaust" is the aggregate of particles ejected by the rocket, the reaction of which imparts velocity to the rocket.

u is the "exhaust velocity," or velocity of the ejected particles relative to the rocket at the instant it begins to move independently from it, unless the force of gravity on the rocket is assumed inconsequential. We will assume that u is constant in any given interval of time. If different exhaust particles leave the rocket with different velocities, then we will assume for u an average velocity such that it can replace all of the actual, disparate particle velocities without altering the sum total of their reactive effect on the rocket; this will be the velocity of the center of gravity of the exhaust after an infinitesimal time interval and is equal to

$$u = \frac{\sum (\alpha \cdot u_\alpha)}{\sum \alpha}, \quad (1)$$

where α and u_α are the masses and velocities, respectively, of the individual particles. It is not too difficult to see that, given the same sum of the kinetic energies; equal to $\frac{1}{2} \sum (\alpha u_\alpha^2)$, u will be a maximum (eq. (1)) when the velocities of all the individual particles are equal.

\underline{j}_0 is the "intrinsic rocket acceleration," equal to the acceleration that the rocket would have if only one force of exhaust reaction were acting on it. It is readily grasped that $\underline{j}_0 = \frac{dM}{Mdt} u$, where dM is the mass of the ejected particles.

μ is the "rocket charge," or the part of the rocket mass intended for consumption, i.e., for conversion to "exhaust."

n is the "flight load rating" = M_0/M_f , whence

$$M_0 = M_f \cdot n; \quad (2)$$

n_i is the "segmental load rating," i.e., the same ratio for a given segment of the flight; $n_i = M_{i_0} / M_{i_f}$, whence

$$M_{i_0} = M_{i_f} \cdot n_i \quad (2a)$$

It is readily seen that always

$$\left. \begin{aligned} M_0 &= M_N + \mu; \quad M_{i_0} = M_{i_f} + \mu_i; \quad \mu = M_f (n - 1); \\ \mu_i &= M_{i_f} (n_i - 1); \\ n &= n_a \cdot n_b \cdot n_c \dots n_i \dots n_z, \end{aligned} \right\} \quad (2b)-(3)$$

where $a, b, c, \dots, i, \dots, z$ are all segments of the rocket trajectory.

W is the "rocket velocity," equal to $\int_0^{t_f} j_0 dt$, where t_f is the burn-out time. In other words, the "rocket velocity" is the velocity that the rocket would develop when not subjected to any external forces and with acceleration imparted to it consistently in the same direction.

We use the symbol j_0 , therefore, to denote just the absolute magnitude of the acceleration irrespective of its direction.

W_i is the "segmental rocket velocity," equal to $\int_{t_1}^{t_2} j_0 dt$, /542

consistent with the preceding notation, where t_1 and t_2 are the times at which the beginning and end of a given segment are passed.

II. Formula for the Load Rating

(Ratio of Initial to Final Rocket Mass)

The basic formula of rocket theory, relating the quantities W , u , and n , has already been advanced by Engineer Tsiolkovski (but in a slightly different form):

$$\frac{M_{i_0}}{M_{i_f}} = n_i = e^{\frac{W_i}{u}} \quad (4)$$

where e is the base of the natural logarithms. We use the subscript i here to denote any segment of the rocket trajectory or the entire trajectory.

We proceed now with the elementary derivation of this formula. Let a rocket with initial mass M_0 eject a train of particles of its own mass at a velocity u in the same direction, where the particles have masses $M_0/k_0, M_1/k_1, M_2/k_2, \dots, M_i/k_i$, where M_0, M_1, \dots, M_i are its masses after each ejection. We then have

$$\frac{M_1}{M_0} = \left(1 - \frac{1}{k_0}\right); \frac{M_2}{M_1} = \left(1 - \frac{1}{k_1}\right); \dots \frac{M_{i+1}}{M_i} = \left(1 - \frac{1}{k_i}\right).$$

Multiplying all of these equations together, we obtain

$$\frac{M_n}{M_0} = \left(1 - \frac{1}{k_0}\right) \left(1 - \frac{1}{k_1}\right) \left(1 - \frac{1}{k_2}\right) \dots \left(1 - \frac{1}{k_i}\right) \dots;$$

the limit of the latter expression for $k_0, k_1, k_2, \dots, k_i, \dots = \infty$ will be

$$e^{-u \sum \frac{1}{k_i}}$$

or, as we are permitted to write, $e^{-u \sum \frac{1}{k_i}}$. Since the velocities of mutually repulsing bodies are distributed as the inverse of the masses, during each injection the rocket will acquire a velocity equal respectively to $u \frac{1}{k_0}, u \frac{1}{k_1}, \dots, u \frac{1}{k_i}, \dots$. The total rocket velocity acquired, therefore, will be

$$W = u \sum \frac{1}{k_i} \quad \text{Substituting into our expression}$$

$$\frac{M_n}{M_0} = e^{-u \sum \frac{1}{k_i}}$$

in place of the velocity $u \sum \frac{1}{k_i}$ the symbol W , we obtain the inverse of equation (4). Equation (4) enables us to determine M_0 and μ when M_f, W , and u are given. /543

We see from equation (4) that when the ratio W_i/u is near zero, n_i becomes almost equal to unity, where $(n_i - 1)$, which difference is proportional to μ_i (eq. (2b)), varies approximately as the velocity ratio W_i/u . Consequently, for $W_i/u \ll 1$, the amount of required charge is insignificant (note 1, Commentary)¹, being approximately proportional to the required rocket velocity and inversely proportional to the exhaust velocity.

For $W_i/u > 1$, n_i will grow as an exponential function relative to W_i (note 2) and can rapidly attain values that would render unfeasible the practical realization of man's flight into interplanetary space. If, for example, to execute the flight, W_i were required to be ten times the value of u that we could attain in actual practice, n_i would acquire a value of about 22,000; for $M_f = 1000$ kg, we would need the astounding value of 22,000 metric tons for the total mass of the rocket. The practicability of flight in interplanetary space and landing on other bodies in the solar system depends, therefore, on how large we can make u and how small a value of W we can get away with for executing the flight.

III. Exhaust Velocity. The Chemical Material

The store of energy needed to impart the exhaust velocity can be carried with the rocket in very diverse forms, but of all these only latent chemical energy in a compound of some of the lightest and most active elements and the energy of decomposition is in proper proportion to the mass of the substance containing them for a value of u sufficient for the practical realization of flight to be obtained. We have far too scarce reserves of radium, and even then we are not able to control the liberation of its latent energy, which takes place much too slowly for our purposes; of all the possible types of "rocket," therefore, we must discuss the "rocket" in the common sense of the word, i.e., the thermochemical rocket, which is invested with the one very powerful advantage that in it the latent energy can be converted into exhaust kinetic energy in very large quantities and with high efficiency for a relatively low weight and simplicity on the part of the accessory equipment subservient to this conversion.

Still another special type of rocket is possible, one which utilizes energy from without, i.e., from the light of the sun. In practice, however, this method of operating a rocket is inapplicable at the present time, or almost inapplicable because of purely technical difficulties:

1544

1) The difficulty of imparting, even with the required energy reserve available, a larger velocity to the exhaust particles than could be produced by the expansion of intensely heated gases in a thermochemical rocket.

2) The difficulty of constructing the necessary reflectors with a suitable area to mass ratio such that the solar energy entrapped by it will be enough to impart sufficient exhaust velocity with sufficient intensity (dM/Mdt , see above). In view of these difficulties, for now we will shelve the idea of a rocket that functions on the energy of solar radiation.

The transformation of the heat of chemical reaction into kinetic energy for exhaust is based on the expansion of gases, hence gases are needed in the composition of the rocket exhaust; however, we are not limited in our choice of chemical composition of the exhaust to gaseous compounds alone. The rocket can function properly if just a portion of the exhaust is gaseous, the other being made up of denser substances atomized in the gas. The gases, expanding in the

rocket tube due to their expansibility and thus acquiring velocity, will entrain particles of the denser substances, at the same time picking up heat from the latter to replace the heat lost in expansion (note 3). In order for this process to go to completion with the greatest efficiency, we need: 1) the most complete entrainment possible of the denser particles by the gases; (2) the most complete transfer possible of heat from the dense particles to the gases. Either of these things will require sufficiently fine and uniform dispersion of the dense particles in the gas and a sufficient interval of time during which they will be in mutual contact, i.e., a sufficiently long rocket tube. The problem of what should be the degree of dispersion, the tube length, and percentage content of dense particles in the exhaust for satisfactory operation of the rocket can only be solved by a series of suitable experiments.

The choice of materials for the charge, therefore, amounts primarily to a choice of a suitable group of materials such that the amount of heat liberated in chemical reaction between its components will be a maximum with respect to each gram of evolved compound, so that we will be able to acquire maximum u . If it should turn out that the reaction products liquify or solidify at temperatures still far from absolute zero, thus losing the expansibility that we require, we would have to supplement the selected group of materials with another, for which the products of reaction between its elements would retain the gaseous state at lower temperatures and thus be capable of converting the liberated heat more completely into kinetic energy. In the simplest case, we might use in place of a second gaseous group the lightest of gases, hydrogen.

The table below lists chemical compounds having the highest heat value per gram mass.

Composition of exhaust	Combustible material		kcal/g	u , m/sec	n_1 ($W_1 = 22,370$)	n_2 ($W_2 = 14,460$)
CO ₂			2.1	4200	205	31
"			2.7	4760	110	21
H ₂ O			3.7	5570	55	13
"			4.4	6080	40	11
CO ₂ +2H ₂ O	CH ₄	H ₂ O liquid	3.3	5250	60	15
" "	"		3.9	5720	49	12
CO ₂ +H ₂ O	Hydrocarbons (petroleum)		2.6	4670	120	22
" "	The same		3.2	5160	73	16
CO ₂ +H ₂ O+9N ₂	Hydrocarbons (petroleum) and liquid air		0.8	2590	5600	250

Composition of exhaust	Combustible material		kcal/g	u, m/sec	n_1 ($W_1 = 22,370$)	n_2 ($W_2 = 14,460$)
$2CO_2 + H_2O$	C_2H_2		3.0	5020	86	18
" "			3.5	5420	62	14
H_2O			3.2	5160	73	16
"		H_2O steam	3.9	5720	49	12
$CO_2 + 2H_2O$			3.1	5070	77	17
" "			3.7	5570	55	13
$CO_2 + H_2O$	Hydrocarbons (Petroleum)		2.5	4580	130	23
" "	The same		3.1	5070	77	17
$CO_2 + H_2O + 9N_2$	The same and liquid air		0.7	2430	9000	300
$2CO_2 + H_2O$	C_2H_2		2.9	4940	95	20
" "	"		3.4	5340	65	15
Li_2O			4.6	6220	36	10
"			5.0	6480	32	9.3
$LiOH$			4.6	6220	36	10
"			5.1	6540	30	9.1
B_2O_3			4.5	6150	38	11
"			5.0	6480	32	9.3
$B(OH)_3$			4.2	5940	43	12
"			5.0	6480	32	9.3
$B(OH)_3$	BH_3		?	?	?	?
Al_2O_3			3.8	5650	52	13
"			4.1	5870	45	12
$Al(OH)_3$			3.7	5570	55	13
"			4.2	5940	43	12

546

Composition of exhaust	Combustible material		kcal/g	u, m/sec	n_1 ($W_1 = 22,370$)	n_2 ($W_2 = 14,460$)
SiO ₂			3.6	5500	58	14
"			4.0	5800	47	13
MgO			3.4	5340	65	15
"			3.7	5570	55	13
Mg(OH) ₂			3.7	5570	55	13
"			4.1	5870	45	12
SiO ₂ +2H ₂ O	SiH ₄		?	?	?	?

The first column of figures gives the heat of combination in kilocalories per gram, minus the latent heats of vaporization in the case of liquid O₂, O₃, H₂, CH₄, C₂H₂, and liquid air.

The second column contains the exhaust velocities in meters per second corresponding to the data in the first column, i.e., the velocities that would be obtained per gram mass if its kinetic energy were equal to the heat energy indicated in the first column.

The third column gives the values of n_1 for

$$W_1 = 22,370 \text{ m/sec} = 2 \cdot 11,185 \text{ m/sec (note 4).}$$

The fourth column gives the values of n_2 for

$$W_2 = 14,460 \text{ m/sec} = \left(2 - \sqrt{\frac{1}{2}}\right) \cdot 11,185 \text{ m/sec,}$$

calculated according to equation (4) in correspondence with the data of the second column. The velocity values 22,370 m/sec and 14,460 m/sec will be discussed below in section VI, IX, and XII.

Inasmuch as the element oxygen is a part of every one of the compounds in which we are interested, each of the compounds is listed twice, corresponding to the two forms of oxygen, O₂ and O₃, where the upper line gives the data for oxygen, the lower line gives the data for ozone, which has a considerably higher store of energy. From here on, we will refer to the active part of the compounds in terms of their nonoxygen components.

We see from the table that the maximum heat effect is given by the lithium and boron compounds. The use of lithium in the rocket charge is dismissed from the outset, because it is incomparably more expensive than boron, while only slightly surpassing it in heat value. Then come the rest of the compounds, in almost systematic order: aluminum, silicon, magnesium, and hydrogen, if we are concerned with the liquefaction of steam, but in reckoning with the gaseous state of water the hydrogen group is somewhat inferior to the metallic group, whereas in reckoning with the liquid state of water with the simultaneous application of ozone, it is slightly superior. Then come the hydrocarbon compounds which yield a mixture of carbon dioxide with water: marsh gas (methane), acetylene, and petroleum; a still smaller effect is given by the pure carbonic radical, and, finally, the compound consisting of petroleum and air. In view of the cost economy of petroleum, which is more convenient for our purposes and yields greater efficiency, the pure carbonic compound is rejected from the outset. As for the hydrogen radical, the question of its application must be left open because of the difficulties in handling it and the expense of liquid hydrogen. It is very likely that the use of the silicon and boron hydride compounds will be better in every respect, especially since we cannot hope to condense the steam in the rocket tube, i.e., to utilize its latent heat of vaporization, in the period during which the rocket develops the greater part of its velocity, when we cannot count on j_0 and dm/dt being made as small as we like, and in all likelihood it cannot be realized in general, since the liquefaction of steam would require a hundred thousandfold expansion or more between exit from the combustion chamber and emergence from the tube. The use of the metal or boron compounds requires the simultaneous application of the hydrogen, boron hydride, or one of the hydrocarbon compounds, otherwise there will not be any excess hydrogen. If minimal cost is the criterion for formulating the charge, the guiding principle must be as follows: application of the most economical compounds¹ for the parts of the charge that are consumed first, and changeover to compounds with a higher heat value ($q/m = \max$) for the parts of the charge to be expended later. According to this principle and the table above, the rocket charge should consist of compounds in the following order:

I. Petroleum; if liquid oxygen proves to be far more expensive than liquid air, the petroleum-plus-air compound should take precedence over this compound.

II. Marsh gas (methane); if it turns out to be possible to obtain low-cost and nonhazardous liquid acetylene, the acetylene compound should take precedence.

III. Hydrogen; its use is contingent upon the cost of manufacturing and storing liquid hydrogen; it is quite possible that the hydrogen compound will

¹In other words, compounds yielding the cheapest reactive effect; the reaction cost is defined by the product $C \cdot q^{-\frac{1}{2}} \cdot m^{\frac{1}{2}}$, where C is the cost of the charge, m is its weight, and q is its heat value.

prove unsuitable and unprofitable and be replaced by the combined use of the marsh gas (methane), metallic (Al, Si, Mg), and silicohydride compounds.

IV. Boron; used together with the hydrogen or borohydride compounds.

The application of the metallic compounds will be discussed further in sections V and IV below. /548

Whether to use ozone and what compound to start with will depend on how cheaply and, mainly, how safely liquid ozone can be prepared; the use of the hydrogen compound will also depend largely on this factor, since the difference between oxygen and ozone becomes the most pronounced in this case.

The compounds O_2 , O_3 , H_2 , CH_4 , C_2H_2 , SiH_4 , and BH_3 can only be carried on the rocket, of course, in liquid form, since in the gaseous state they would require tanks of enormous volume and weight; boron must be carried as an amorphous powder, which, is pulverized in the combustion chamber by a jet of hydrogen or marsh gas, or is mixed in with petroleum before being sent to the combustion chamber. B, Si, and H_2 can be carried in the form of BH_3 , B_2H_3 , and SiH_4 , as well as in the form of boro- and silicohydrides. The author regrets that he has not had the opportunity to locate thermochemical data pertaining to these extremely interesting compounds. The metals can be used in the molten state or, as with boron, in powder form.

It is difficult to estimate beforehand the efficiency of the rocket, i.e., the relative amount of heat that will be converted into exhaust kinetic energy; it will depend primarily on the degree of expansion of the gases in the rocket tube, i.e., on the ratio of the initial to final expansibilities. The latter will depend, however, on the ratio of the exhaust mass (dm/dt) to the exit cross section of the tube and, in addition, cannot be less than the expansibility of the surrounding atmosphere. The efficiency of the rocket will therefore be greater during those periods of the flight when the rocket is a free cosmic body in empty space, when the quantities j_0 and dm/dt will be sufficient no matter how small, and the efficiency will be lower in those periods of flight when the rocket is within the boundaries of an atmosphere of substantial density and when it will require a j_0 at least as great as some critical value (sections VI and VIII). Under the above conditions, the efficiency will clearly be on the order of 50 to 75%. To raise the efficiency, we will have to have as large an initial pressure as possible (in the combustion chamber) and as low a final pressure as possible (in the end of the rocket tube) (note 5); in order to do this without increasing the tube cross section or the overall cross section of the rocket and concomitant atmospheric drag, it may prove more expedient to replace one exit tube by several distributed in sequence and emerging at a small angle with respect to the lateral surface of the rocket; the stern of the rocket in this case could be made with a pointed, streamlined shape. These exit tubes could be fed from one or more combustion chambers, whatever proves to be best from the design standpoint. Due to the incomplete utilization of the heat of chemical reaction, the actual values of u will be less than indicated in the table. If the efficiency were equal to 50 to 75% /549

the actual value of u would be equal to about $3/4$ or $7/8$, respectively, of its computed value, in correspondence with which n would have a value of $n^{4/3}$ or $n^{8/7}$ with respect to the computed values.

IV. The Combustion Process, Construction of the Combustion Chamber and Exit Tube

A very important problem concerns the temperatures in the combustion-chamber and in the exit tube. If complete combination of the exhaust components could be immediately realized, the temperature in the combustion chamber would rise to

$$T = 208 Q_m, \quad (5)$$

where Q (kcal/g) is the mean heating capacity per gram of the compound, m is the mean molecular weight of the exhaust, assuming it is gaseous. For solid and liquid products, the temperature would be even higher. The occurrence of molecular dissociation at high temperatures, however, does not permit the chemical reaction to go to completion at once; at some temperature (above 3000°C) chemical equilibrium sets in for all reactions, after which further reaction will only be possible with increasing heat loss by the gases as they expand in the exit tube. Consequently, the thermal energy of the reactions will be realized primarily, not by an adiabatic process but by a more nearly isothermal process. An adiabatic process sets in when the gases, after expanding in the tube, lose so much heat that the reactions can continue to completion without raising the temperature of the mixture to a point where its components suffer appreciable dissociation. These effects are of considerable importance in the construction of the rocket; to evolve the same amount of heat of combination with gradual combustion we must have a larger ratio of final to initial volume occupied by the gases, i.e., larger dimensions on the part of the exit tube. On the other hand, in the combustion chamber and in the beginning of the exit tube, we will have a lower temperature than that which would exist with complete combustion in the chamber. It is clear from equation (5) that, given a certain limiting temperature in the combustion chamber based on design considerations, we will obtain far more complete initial combustion and a faster total combustion for compounds with a lower molecular weight. From this point of view, the most suitable compounds are those with H_2 , CH_4 , C_2H_2 , petroleum, and Li, somewhat less appropriate are SiH_4 , BH_3 , and the least suitable are the purely metallic compounds with Si, Mg, boron, and, especially, aluminum.

It will be necessary to do the following in constructing the combustion chamber and exit tube: those surfaces which will be exposed to temperatures higher than can be tolerated by the most refractory materials must be metal (copper or one of the high-melting metals like chromium or vanadium) and subjected to powerful cooling from the outside by the liquid gases being fed into the combustion chamber. It does not appear possible to calculate this cooling until suitable experiments have been carried out on the amount of heat that will be acquired by the surfaces of the chamber through radiation and thermal conduction from the hot mixture. All other surfaces can be internally lined with sufficiently refractory materials, insulating them as far as possible from the

exterior construction, which could, if necessary, be moderately cooled. If it proves inconvenient or unfeasible to bring the temperature in the combustion chamber and in the beginning of the tube down to a point where appreciable dissociation of the exhaust components will not occur, we can maintain it artificially at some specified level by not feeding one of the charge materials (metals or oxygen) into the combustion chamber right away, instead just part of it, delivering the remainder of it in different parts of the tube as heat is lost from the originally specified mixture.

V. The Proportional Passive Load

In the passive mass of the rocket, i.e., the mass μ not belonging to the charge, we can distinguish two essentially different parts:

1) The absolute passive mass m , which includes the personnel and all that is necessary for them to live and perform their allotted tasks, as well as for operation and safe descent to the earth's surface when the rocket ceases to function as such.

2) The proportional passive mass m_1 of all objects subservient to the functioning of the rocket, including: a) the tanks containing the charge, b) the combustion chambers, c) the exit tube, d) the instruments and machines for mixing the charge substance in the combustion chamber, e) all parts connecting the objects in the first four categories and reinforcing the overall construction of the rocket. This part of the passive mass is called the "proportional passive load," in view of the fact that, according to design precepts, its mass must in general be approximately proportional to the mass of the charge with which it is associated, as long as the latter does not exceed some value; for large values of μ the ratio m_1/μ will increase.

The starting point for construction of the rocket is its preestablished mass m , which, once given, must be matched by μ and m_1 ; m remains constant throughout the flight; u is gradually used up, and m_1 may vary, hopefully, in 551 correspondence with the diminishing masses of the charge (μ) and the exhaust products (dM/dt).

We designate the ratio $m_1/u = q$ and postulate that we have one and the same irremovable passive load m_1 functioning the whole time. Then

$$m_1 = \mu q; M_f = m + m_1 = m + \mu q.$$

Substituting this value of M_f into equation (2b), we obtain

$$\mu = (m + q\mu)(n - 1),$$

whence

$$\mu = \frac{m(n-1)}{1-q(n-1)}, \quad (6)$$

whereas for $m_1 = 0$ we would have $\mu = m(n-1)$.

We see from equation (6) that as long as $q \ll \frac{1}{n-1}$, we will obtain values for μ only slightly different from those which would occur for $m_1 = 0$ (note 6), but with increasing q the mass μ will increase, going to infinity at $q = \frac{1}{n-1}$, which means that it is theoretically impossible to build a rocket for such data. But the practical feasibility is less stringent; for $q = \frac{1}{2(n-1)}$, we would obtain already twice the charge (note 7). But for the mass of the rocket not to increase too much due to the presence of the mass m_1 and the need for imparting to it a velocity consistent with m , it is desirable to have the approximate relation

$$q \ll \frac{1}{5(n_i - 1)} \quad (\text{note 8}), \quad (7)$$

where n_i is the load rating for that segment along which the same m_1 functions without change and at the completion of which it can be rejected so as not to burden the rocket unnecessarily with its surplus mass, after which another unit m_1 begins to function, of smaller dimensions and smaller mass, in correspondence with the reduced masses of the charge and exhaust. Both sides of the inequality (7) are not identically amenable to our efforts to change them; the quantity q is determined by the degree of technological perfection in building the objects m_1 and may be larger or smaller, depending on a variety of conditions, but it does have a certain rigorous minimum, which, with the materials at our disposal and with the present development of engineering design, we are not now in a position to surmount. We can decrease the quantity n_i at will down to unity (note 9), by dividing the trajectory of the rocket into a larger number of segments with a smaller W_i for each. The number of segments and, accord- 1552
ingly, the number of units m_1 is determined as a function of the relative amount of expended charge that we find convenient for the use of one invariant unit m_1 ; specifically this number should be equal to $\log n : \log n_i$, where n_i is the load rating of each segment of the trajectory. Should we wish to use a one-unit system for the entire flight, we would obtain too insignificant an absolute limit for the quantity q . The theoretical minimum W necessary for completing the flight purely by rocket means is equal, as we shall see below, to 22,370 m/sec; the corresponding values of n_i , calculated on the assumption of 100% efficiency on the part of the rocket, are given in the third column of figures in the table on pages 64 to 66.

Considering all of the sources of energy loss and imperfections, we can say that the actual value of n for $W = 22,370$ m/sec will be at least 100, and if we wish to cheaply formulate the charge and partially use hydrocarbons, it will be more than 100. Consequently, for $q = 1/99$, the mass of the charge according to equation (6) would already be infinite, for $q = 1/200$ it would have doubled, whereas $\mu/200$ is a very compact quantity, more correctly impossible for

the mass of the total unit m_1 . Even if we let $W = 14,460$ m/sec and, accordingly, assume $n_2 = 20$ (page 65), we still obtain twice the charge with the difficult-to-realize ratio $m_1 = \mu/40$. In practice, therefore, the optimum system will be a two-unit one for the machines and instruments and a three-unit version for the tanks, as the bulkier constituents of m_1 . If we again let $n = 100$, the absolute limit of q is lowered from $1/99$ (for the one-unit system) to $1/9$ for the two-unit, and to $1/3.9$ for the three-unit system (note 10). A several-unit system, although it provides more space in the construction of the objects of m_1 and saves us from shelving the whole undertaking because of the unfeasibility of building m_1 sufficiently lightweight, it nevertheless does not entirely eliminate the undesirable influence of the masses m_1 on the mass of the rocket; the value of μ according to equation (6) still turns out to be larger than that which we would have if m_1 were entirely absent.

If we assume a multiunit system, dividing the trajectory into several segments with equal W_i for each, then for the total flight we obtain an increase in mass by the factor

$$\left(\frac{1}{1 - q(n_1 - 1)} \right)^K \quad (6a)$$

(where K is the number of segments), compared with the mass that the rocket ⁵⁵³ would have if m_1 were absent.² The power exponent in this equation is based on the addition of $m + m_1$ to the right-hand side of equation (6) and removal of mn_1 from the bracketed expression (note 11).

A solution of the problem concerning m_1 can be suggested, for which the harmful influence of the mass m_1 is almost entirely eliminated. This solution is contained in the following. As with the multiunit system, several units m_1 are constructed in successively diminishing sizes; the material for construction is, insofar as possible, predominantly aluminum, silicon, magnesium; parts requiring special refractory characteristics (inner surface of the combustion chamber) are made of suitable kinds of graphite, carborundum, corundum.

² In the limit at $K = \infty$, the fraction in equation (6) assumes a value

$$e^{q\mu} = e^{q \frac{W}{u}} \& \frac{M_p}{M_f} = e^{\frac{W}{u}} e^{q \frac{W}{u}} = e^{\frac{W}{u}(1+q)}$$

(Noted by V. P. Vetchinkin.)

The units, as they become surplus due to the diminishing mass of the rocket, are not discarded but are broken down and fed into the pilot's compartment for remelting and comminution, so that they can subsequently be used as chemical components of the charge. This solution is the ideal one, because all that remains of the harmful mass m_1 is the last and smallest unit, while all of the previous ones are used for the charge, gradually exhausting the functions of m_1 . Since the breakdown and subsequent conversion of the objects m_1 requires a certain amount of time, in such a system the division of the rocket trajectory into segments associated with the invariant units m_1 is no longer arbitrary; the first change of units cannot be performed before the rocket has entered into the free earth satellite state; the last changeover cannot be made after the rocket has lost so much velocity in returning home that it cannot function as a free earth satellite. These two changeovers are best limited so that they correspond to a division of the trajectory into three segments with approximately equal W_i for each. To break down the objects m_1 in empty space and convert them into charge materials requires certain additional equipment. Nevertheless, every effort should be directed toward this solution of the problem of m_1 , because it will facilitate the main difficulty of the whole undertaking, reducing the required mass of the rocket, which if very large constitutes a very real obstacle to the conquest of interplanetary space and the bodies in our solar system, and is exceedingly difficult to overcome in practice, although theoretically the objective does not present any particular difficulties.

VI. Types of Trajectories and Rocket Velocities Required

554

We will adopt the following notation:

- I_j Segments of the rocket trajectory along which it functions, i.e., imparts acceleration to itself.
- w_e The "escape velocity" for a given state of the rocket; that velocity by which the existing velocity of the rocket must be increased in order for it to assume motion in a parabolic orbit to the center of the earth.
- w_r The "return velocity" for a given state of the rocket; that velocity which the rocket would have if, continuing in its orbit, it reached the surface of the earth (sea level).
- w The "total escape velocity" and "total return velocity," equal to w_e as computed for the state of rest at the level of the earth's surface, or equal to w_r as computed for the state of rest at an infinite distance from the earth or for the rocket moving in a parabolic orbit, equal to the "parabolic velocity" = $\sqrt{2Rg}$ (where R is the earth's radius, g is the acceleration due to the earth's force of gravity) = 11,185 m/sec.

- v Velocity of the rocket relative to the center of the earth (not the earth's surface) at a given instant.
- r distance from the rocket at a given instant to the center of the earth;

$$\vec{r} = \frac{r}{R} .$$

By the term "flight" we mean the motion of the rocket to some point at an infinite distance from the earth, and the return from that point, where the velocity of the rocket at the designated point and at the earth's surface must be equal to zero. We will ignore for the moment atmospheric drag and the presence of other bodies in space besides earth, so that our results of this section will be approximately valid only for segments of the trajectory lying outside the significantly dense part of the atmosphere and not in the vicinity of the moon, as well as for trajectories whose dimensions are considerable in comparison with the radius of the earth's orbit.

It is readily seen that for any state of the rocket we will have the following:

$$w_e = \frac{w}{\sqrt{r}} - v; \quad w_r = \sqrt{v^2 + w^2 \left(1 - \frac{1}{r}\right)}. \quad (8)$$

For a rocket in the earth satellite state with a circular orbit:

$$w_e = v(\sqrt{2} - 1) = \frac{w}{\sqrt{2r}} (\sqrt{2} - 1) \quad \text{(note 12)} \quad 12)$$

$$w_r = \sqrt{w^2 - v^2} = w \sqrt{1 - \frac{1}{2r}}$$

In the case when the orbit of the rocket does not touch or cross the 1555 earth's surface, as in the example of any circular orbit, our definition of the quantity w_r is fictitious. In this even, w_r must be interpreted as the velocity that the rocket would have if to its kinetic energy were added the energy due to its mass and difference in the gravitational potential energy of the earth between its position at a given instant and the level of the earth's surface, regardless of whether or not this summation of energies can actually be performed as the rocket moves in its given trajectory. It is not too difficult to see, then, that w_e has different values for points at different distances from the earth in the same orbit (provided only that the orbit is not parabolic, in which case $w_e = 0$); w_r , on the other hand, has a constant value for all points on the same orbit. The quantities w_e and w_r have the following significance:

1) The value of w_e for the perigee (the point of the orbit nearest the earth's center) is the theoretical minimum of W (i.e., computed only the basis of the law of energy conservation) necessary for the rocket, moving in a given orbit, to acquire motion in a parabolic orbit such that the rocket can execute the first half of its "flight," i.e., the motion to a point at infinity.

2) w_r is the theoretical minimum of W necessary for the rocket, moving in a given orbit, to reach the earth's surface with zero velocity and thus complete the second half of its flight.

For proof of the first postulate we compare w_{e_1} and w_{e_2} , computed for two points a_1 and a_2 in the same orbit, where the difference in earth-gravitational potential energy is equal to an infinitesimal quantity α . If for the more distant of the points, say a_1 , we have, according to equation (8),

$$w_{r_1} = w \sqrt{\frac{1}{r} - v^2},$$

then for the nearer point a_2 we obtain

$$\begin{aligned} W_{e_2} &= \sqrt{\frac{w^2}{r} + 2\alpha} - \sqrt{v^2 + 2\alpha}, \text{ but } \lim_{\alpha \rightarrow 0} \left[\sqrt{\frac{w^2}{r} + 2\alpha} - \right. \\ &\quad \left. - \sqrt{v^2 + 2\alpha} \right]_{\alpha=0} = \left(w \sqrt{\frac{1}{r} - v^2} - v \right) - \alpha \left(\frac{1}{v} - \frac{v}{w} \right) = \\ &\quad = w_{e_1} - \alpha \left(\frac{1}{v} - \frac{v}{w} \right) \end{aligned}$$

(since for elliptic velocities $v < w/\sqrt{r}$, it follows that $1/v > \sqrt{r}/w$ and the quantity in the parentheses is positive - noted by V. P. Vetchinkin).

Consequently, in absolute value, which is all that concerns us, $w_{e_2} < w_{e_1}$. Therefore, w_e has a minimum at the perigee of the given orbit, which is the theoretical minimum of the rocket velocity needed for transition to a parabolic orbit, Q.E.D. /556

For proof of the second postulate, we compare two values w_{r_1} and w_{r_2} obtained in two situations: one, in which the rocket moves in a certain orbit and acquires a velocity increment u at the point a_1 ; another, where it moves in the same orbit with the same velocity and acquires the same negative velocity increment at another point a_2 , the difference in gravitational potential

energies between the points a_1 and a_2 comprising an infinitesimal quantity α . If in the first instance we have, according to equation (8),

$$w_{r_1} = \sqrt{(v - u)^2 + w^2 \left(1 - \frac{1}{r}\right)},$$

then in the second instance we obtain

$$\begin{aligned} w_{r_2} &= \sqrt{(\sqrt{v^2 + 2\alpha} - u)^2 + w^2 \left(1 - \frac{1}{r}\right) - 2\alpha}, \text{ but} \\ \lim [w_{r_2}]_{\alpha=0} &= \sqrt{(v - u)^2 + w^2 \left(1 - \frac{1}{r}\right)} - \alpha u: \\ &: v \sqrt{(v - u)^2 + w^2 \left(1 - \frac{1}{r}\right)} = w_{r_1} - \alpha u : v w_{r_1}. \end{aligned}$$

Consequently, $w_{r_2} < w_{r_1}$, and, the nearer to earth the points at which deceleration is applied, the smaller will be the value of w_r . We obtain the minimum w_r by applying negative velocity increments to the rocket at the level of the earth's surface. In order for the rocket to complete its flight, we must eliminate at the earth's surface the entire velocity that the rocket possesses, which will equal w_r for a given orbit, Q.E.D.

The two foregoing postulates can be explicated as follows.

A certain expenditure of charge on the part of the rocket imparts to it some definite positive or negative velocity increment, independently of the state of rest or motion of the rocket itself, but inasmuch as the energy of the rocket relative to earth - its kinetic energy - is proportional to the square of its velocity relative to the earth, a certain given velocity increment will constitute a larger positive or negative increment in the kinetic energy when 557 it occurs for a larger initial velocity of the rocket; for instance, a velocity increment equal to 4, applied to a velocity of 2, will mean an increment in the kinetic energy of

$$\frac{6^2 - 2^2}{2} = 16,$$

whereas the same velocity increment, equal to 4, applied to a velocity of 20, will represent a kinetic energy increment of

$$\frac{24^2 - 20^2}{2} = 88.$$

Consequently, from the point of view of the rocket's energy relative to earth, the exhaust will produce a greater reaction on the part of the rocket the higher the velocity of the rocket itself. But the velocity of the freely moving rocket will be greatest at the point of closest approach to earth, hence the reaction at this point will be most favorable, both when it is necessary to impart to the rocket sufficient energy for escape from earth and when it is necessary to deplete its energy for favorable descent to earth.

Thus we see that W can attain a minimal value $2w$ only under the necessary (but still insufficient) condition that all accelerations and decelerations be executed at the earth's surface; since this is impossible, W will be smaller, the nearer to the earth's surface the segment I_j is located. Hence, nearness to the earth's surface of all segments I_j of the rocket's self-imparted acceleration if the prime requirement that we must impose on the rocket trajectory to preclude a superfluous increase in the rocket velocity W . We call the difference $W-2w$ the "rocket velocity surplus" and denote it by the symbol L . We denote by L_i the surplus of a given segment, or that part of the total surplus L which was a nonminimal result of the conditions under which the rocket traversed a given segment of its trajectory.

In general,

$$L_i = W_i \pm \left\{ v_2 - v_1 + w \left(\sqrt{\frac{1}{r_1}} - \sqrt{\frac{1}{r_2}} \right) \right\}, \quad (9)$$

where $v_1, v_2, \bar{r}_1, \bar{r}_2$ are the respective values of the quantities at the beginning and the end of the i th segment. The upper sign should be used for "elliptic" rocket velocities ($v < w \sqrt{1/\bar{r}}$) for the first half of the "flight"; in all other cases the lower sign should be used.

If the difference in gravitational potential energy at the ends of a given segment is equal to the infinitesimal quantity α , we will have the following in a flight without resistance of the medium: /558

$$L_i = \pm \alpha \left(\frac{1}{v} - \frac{V\bar{r}}{w} \right). \quad (10)$$

The upper sign should be used for elliptic velocities, the lower for hyperbolic velocities. The parabolic trajectory does not yield a velocity surplus in itself, since always in this case

$$w \sqrt{\frac{1}{r}} = v.$$

A subscript on the symbol L will be used to denote the particular physical factor giving rise to the surplus velocity. For example, in equation (10) we have L_{ig} , because the surplus is due to gravitational acceleration; the subscript s will be used to indicate the summed effect of all factors, d the effect of atmospheric drag, with two subdivisions d_p and d_v , of which more will be said below in section VIII. According to the discussion, of all the possible trajectories, L necessarily gives those whose elements are the elements of free orbits that do not touch or intersect the surface of the earth, because with such an element present in the trajectory, the "first requirement" (see above) is clearly not fulfilled. Maximum L gives the presence of a circular orbit of some finite radius in the trajectory.

The second requirement which we must impose on the rocket trajectory in order to attain the smallest possible L is that the angle β between the direction of the reactive force and the tangent to the trajectory be as small as possible. The absolute value of v varies not as a function of the total self-imparted acceleration of the rocket j_0 , but only as its tangential component, equal to $j_0 \cos \beta$; we obtain, therefore,

$$L_{i\beta} = W_i (1 - \cos \beta). \quad (11)$$

We divide the trajectory of the total flight arbitrarily into three segments.

1) T_e , the "escape trajectory," or the segment beginning at the earth's surface and ending at some infinitely distant point.

2) T_c , the "connecting trajectory," or the segment beginning at the end of T_e and ending at some other, infinitely distant point.

3) T_r , the "return trajectory," or the segment beginning at the end of T_c and ending at a point on the earth's surface. In correspondence with the indicated notation, we will adopt the notation W_e, W_c, W_r . We also denote the 559 following:

θ The angle between the trajectory at a given point and the horizon plane.

β The angle between the direction of intrinsic acceleration j_0 and the trajectory at a given point of the latter.

$\lambda = \theta + \beta$ is the angle between the direction of j_0 and the horizon plane. The angles θ and β are considered positive when the tangent to the trajectory is directed upward from the horizon plane, while j_0 is directed upward from the tangent to the trajectory.

The reasoning behind our division of the trajectory is the following. At infinity from the earth the earth's gravity is inconsequential and there is no drag from the earth's atmosphere. Consequently, T_c can take on any shape whatsoever and, regardless of the shape, it can be negotiated by the rocket with arbitrarily small j_0 , v , and W_c , because it lies entirely at an infinite distance from the earth.

In practice, a segment of the trajectory situated at a distance a few multiples of ten times the earth's radius from the earth can be equated to T_c . W_c is determined in practice largely by the amount of time that we agree is convenient for traversal of T_c .

T_e and T_r , on the other hand, have parts lying within the sphere of influence of earth's gravity and parts within a resistive medium, the atmosphere. Consequently, a particular quantity L , and hence W , will depend entirely on the geometric shape and velocities that we choose for T_e and T_r ; in our subsequent analysis of trajectory types, therefore, we will be concerned only with the segments T_e and T_r , ignoring the comparatively unimportant segment T_c .

Since, in the absence of resistance from a medium, segments T_e and T_r which are identical in configuration and absolute value of the velocities at similar points require equal accelerations at similar points in order to be identical, the quantities W_e and W_r for these T_e and T_r will also be equal. The computations given below pertain identically to T_e and T_r , since they lie outside the limits of a significantly dense atmosphere.

It is not difficult to grasp the impossibility of constructing a trajectory that would simultaneously correspond to both requirements outlined above for minimizing the velocity surplus L . A type of trajectory that fully meets the "second requirement" is a "radial" trajectory, for which T_e and T_r represent continuations of the earth's radii. In accordance with the "first requirement," we must minimize I_j in a radial trajectory, imparting to the rocket at large a value of j_0 as possible, starting with the point of departure and continuing to the point at which the rocket attains the parabolic velocity $v = w \sqrt{1/\bar{r}}$; in returning from the corresponding point, it will be necessary to begin with j_0 , the "intrinsic deceleration" of the rocket.

We will assume for simplicity that the gravitational acceleration over 560 the entire extent I_j is the same as on the earth's surface, g . We denote

$$\overline{j_0 + j_p} = j \ \& \ j : g = \bar{j},$$

where j_0 is the intrinsic acceleration, j_ρ is the deceleration imparted to the rocket by the force of atmospheric resistance, and j is their vector sum (in the present case, with a radial trajectory, it is equal to the algebraic difference), which we will call the "mechanical acceleration," in correspondence with which \bar{j} is the ratio of the mechanical acceleration to the gravitational acceleration. With these assumptions and notation, we have from equation (9)

$$L_g = w \left(\sqrt{\frac{\bar{j}}{\bar{j}-1}} - 1 \right) \text{ (note 13)} \quad (12)$$

or, simplifying for $\bar{j} \gg 1$,

$$L_g = w \frac{1}{2(\bar{j}-1)}$$

These values, which are somewhat larger than the actual values for finite \bar{j} , are taken as approximate values of the surplus from the influence of the force of gravity in a radial trajectory, assuming $\bar{j} \geq 5$ (for small values of \bar{j} , a radial trajectory is unsuitable everywhere).

The type of trajectory corresponding to the "first requirement" is a "tangential" trajectory (see fig. 1); from the point of departure 0 to the point b the rocket moves parallel to the earth's surface via the arc of a large circle; the rocket attains horizontal motion by directing j_0 at an angle β with respect to the horizon and trajectory such that the force $Mj_0 \sin \beta$ will counteract the amount by which the gravitational force on the rocket exceeds its centrifugal force; up to the point d_1 , the angle β must be positive, but after this point, at which $v = w \sqrt{1/2}$, β is made negative, since the centrifugal force will already exceed the force of gravity. The circular motion continues until the angle β required for its maintenance, ever increasing (in absolute value) with increasing velocity and centrifugal force, attains a value such that L_β (eq. (11)) becomes an appreciably deleterious part of the surplus.

When β (corresponding to the rocket velocity) attains such a value, the rocket moves for a certain time at constant β , moving further away from the earth's surface at an ever-increasing angle θ . When at the point b_1 the factor L_g becomes essentially disadvantageous due to the ever-increasing difference in potential energy between the position of the rocket at a given instant and the perigee of the orbit along which the rocket would have moved had j_0 been discontinued (for the effect of this difference on W_e , see page 74), the rocket ceases to function, and from the point b_1 to the point b_2 the rocket moves freely along an elliptic orbit. At the point b_2 , which is symmetrical to b_1 (relative to the major axis of the ellipse), j_0 is renewed at $\beta < 0$, such that

561

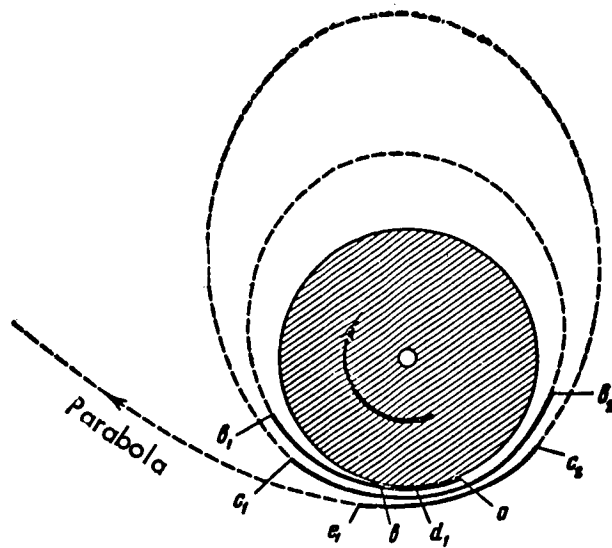

Figure 1. Tangential Trajectory.

The heavy lines indicate T_g ; the dashed lines indicate the segments of free flight along elliptic and parabolic orbits.

I_j will be traversed as near the earth as possible, and is continued to the point c_1 corresponding to the same condition as the point b_1 ; after the point c_1 it again follows a free elliptic orbit $c_1 - e_2$, then again an $I_j = c_2 - e_1$ near the earth's surface, and so on, until in traversing the last I_j we attain the required parabolic velocity and orbit. In the tangential trajectory, the $L_{g\beta}$ which is attained after the rocket passes the point d_1 can theoretically be made as small as we like by moving the points d_1 and b , b and b_1 , b_2 and c_1 , c_2 and e_1 , etc., sufficiently close together; the only thing to consider is that the number of elliptical intervals and flight time will be increased. We will neglect this part $L_{g\beta}$ as being largely dictated by our wishes; by contrast, the l_β obtained by the point d_1 has a definite theoretical minimum, equal approx-562 imately (for $\bar{j} \gg 1$) to

$$L_\beta = w \frac{1}{6\bar{j}^2} \cdot \quad (13)$$

We will use this approximate value in our later analysis. Besides having a surplus of less than $3\bar{j}$, the tangential trajectory has the further advantage that, by launching and returning the rocket in the equatorial plane from west to east, we can utilize the earth's rotation about its own axis to obtain for

the whole flight an economy of the rocket velocity W , equal to twice the velocity of motion of the earth's surface:

$$2U = 920 \text{ m/sec.}$$

In addition to the difficulty of precise control of the required tangential trajectory, it has one added disadvantage, which makes its application in pure form for departure impossible; the tangential type T_e requires points of departure outside the significantly dense atmosphere, because otherwise, due to the considerable length of the segments situated on a level with the point of departure and somewhat above it, L_g would increase by an incredible amount, many times exceeding the savings in W obtained from the smaller surplus $L_{g\beta}$ for a tangential trajectory and from utilization of the earth's rotational velocity. In practice, therefore, the most favorable type of T_e is not tangential, but a certain compromise, beginning with a spiral arc, as shown in the example of figure 2. The angle θ for this spiral should be smaller, the smaller the admissible value of j_0 (and, hence, the larger will be our value of $L_{g\beta}$), and the smaller the deceleration j_ρ elicited by atmospheric drag. For this middle type of trajectory, $L_{g\beta}$ will have a value midway between $w/2(\bar{j}-1)$ and $w/6\bar{j}^2$.

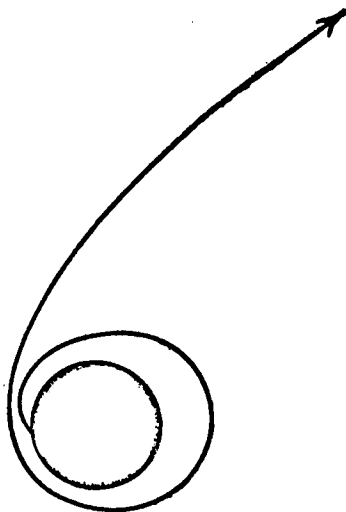

Figure 2. A Hybrid Type Trajectory.

Below, we will assume that for $\theta < 30^\circ$ and for $\bar{j} > 3$, provided the rocket does not use airplane wings, or for $\bar{j} > 1$ when the rocket does use them,

$$L_{g\beta} = \frac{w \sin \theta}{3\bar{j}} \quad (14)$$

with the necessary condition that aviation type lifting surfaces are used, /563
provided only that $j < 2$. As for the tangential type T_r , it is applicable in essentially pure form and can yield very considerable economy in W_r , due to the useful aspect of atmospheric resistance in the return flight, which helps to attenuate the return velocity of the rocket. This will be discussed separately below, in section IX.

VII. Peak Acceleration

We see from equations (12), (13), (14) that L , hence W and n , decrease with increasing j and \bar{j} ; it is important, therefore, for us to find out what is the maximum mechanical acceleration j that we can impart to the rocket. The "mechanical acceleration" is the acceleration elicited by the resultant forces acting exclusively on the external parts of the rocket, which is then the acceleration felt inside the rocket, whereas the gravitational acceleration, applied identically to all parts of the mass of the rocket, will not be perceptible inside it. The limiting value of j can be hypothesized in terms of four factors: 1) the capability and endurance of the rocket construction; 2) endurance of the pilot's organism; 3) atmospheric drag, which increases with increasing velocity and can make the application of smaller j more advantageous while passing through the atmospheric layers of appreciable density, equations (12), (13), and (14) notwithstanding; 4) design problems in the building of sufficiently lightweight and portable components of the proportional passive load (tanks, pumps, burners, etc.), which will have sufficient performance capabilities to impart large acceleration to the rocket.

The third factor may be of significance only for a relatively small segment near the earth's surface; this will be discussed further in section VIII. The endurance of the rocket depends on how durable we wish to build it. Factors which may contribute to the upper limit of j for a large part of T_e are, therefore, endurance of the human organism, this factor being the least prone to our efforts to enhance it, and the dimensions of the objects m_1 , which we can make lighter more portable than some limit dictated by modern mechanical engineering.

Too large a value of j can prove harmful and even fatal for the pilot, in that all fluids of the living organism and, above all, the blood tend toward those parts of the body which are situated opposite to the direction of apparent gravity created by the acceleration j . If, for example, to a man 200 cm (about $7\frac{1}{2}$ feet) tall we were to impart an acceleration $j = 10 g$ for a sufficient period of time in the lengthwise direction of his body, from toe to head, a dif-/564ference of about two atmospheres would be developed in the blood pressure between the soles of the feet and forehead region, which is probably quite enough for the head to become completely drained of blood, and the feet would become charged with blood vessels, unless special precautions were taken against these effects. The first condition for the organism to be able to bear the acceleration j is to reduce the height of the blood column as much as possible in the direction of acceleration, i.e., to recline the body in an attitude perpendicular to the direction of j . The inflow to the "lower" (i.e., lying opposite the direction of j) parts of the body and drainage of blood from the

"upper" parts can be inhibited by counteracting the internal difference in blood pressure with the same difference in external pressures on the part of a liquid with the same density as the blood, in which the body would have to be immersed. Otherwise, the movement of the blood masses can be inhibited by seating the body in a smooth, hard, everywhere tightly form-fitting contour.

Any method that serves equally to prevent fluid drainage in the external surfaces of the body (when large accelerations are applied), is completely inapplicable to the internal surface of the lungs. Yet it is in the internal surface of the lungs that the most delicate blood vessels are found, intimately intermingled with the air sacs, without even the most diaphanous tissues to separate them. Since the absolute density of the air in the lungs is insignificant in comparison with the blood density, the pressure difference dh_j obtaining between the "upper" and "lower" surfaces of the lungs, where d is the absolute density of the blood, h is the dimension of the lungs in the direction of j , cannot in any way be compensated from without, i.e., from the space of the lung vacuoles. If this difference exceeds the limiting resistance of the capillary vessels and tissue of the lung vacuoles, first there will be rupture, after which the "lower" surface of the lungs will become engorged with blood.

By its structure, the chest cavity presents still another impediment to the development of large accelerations; it contains a number of organs or relatively disparate densities, the heart and lungs. With the communication of acceleration to the body, the heavier heart will suffer a displacement in the opposite direction inside the chest, which can, if the effect is intense enough, have a pernicious effect on the activity of the heart and its neighboring left lung, the latter becoming deformed. Consequently, the permissible limiting acceleration for the human organism will be dictated by the resistance of the internal surface of the lungs to rupture and the resistance of the attaching members of the heart to displacement. Thus, in whatever direction the heart will best withstand stress, forward or backward, will determine whether the man should have his chest or his back in the direction of acceleration. The endurance of the lungs can be enhanced considerably by turning the body about its long axis, which will be perpendicular to the direction of acceleration. With such rotation, we would probably find that the blood would not have a chance to flow to any part of the lung, since all would be changing their positions gradually relative to the direction of apparent gravity. With such rotation of the body, the heart would no longer suffer a constant displacement in one direction, but would tend to move in a circle, which would affect both the organ itself and its neighboring left lung, although in just what measure is not known. /565

An exhaustive, well-grounded investigation of the endurance to j on the part of the human organism can be carried out very well on a large centrifuge, the most practical and least expensive type of which for our purpose would be something like a "giant stride" with two cables, one of which holds the experimental chamber with pilot, the other holding a counterweight. We can obtain some indications as to the magnitude of the permissible j from experiments on the giant stride and present-day aviation tests. On the giant stride, the acceleration attained is often as high as $2g$ and can be continued for a fair amount of time, while aviators performing stunt flying withstand short-term accelerations up to $8g$, as well as fairly prolonged accelerations to $2g$. In either

case, no really harmful effects are observed (note 14). Bearing in mind that in swinging on the giant stride and in airplane flights, the position of the human body relative to the direction of j is usually lengthwise, i.e., in the most unfavorable position, in that the dimensions of the lungs in the direction from the shoulders to the pelvis are the largest, we have good reason to assume that under favorable conditions, namely with the body primarily in a transverse attitude, the human being could stand an acceleration $\bar{j} = 5g$ for a period of three minutes (more is not required) without any particular harm. If it should prove possible to apply rotation of the body about its long axis, the value of permissible \bar{j} might even surpass $10g$. The value of $L_{g\beta}$ corresponding to $\bar{j} = 5g$ will be: for a radial trajectory $w = 0.125$ and for a tangential trajectory $w = 0.007$. To the value $L_{g\beta} = 0.125 w$ for $2w : u = 5$, which is the relation we will approximately realize in actuality, corresponds a 1.87-fold increase in n . As for the design capabilities in building the objects comprising the proportional passive load so that they are sufficiently portable with a high performance rating in attaining an appropriately large j_0 , this problem must await the corresponding engineering research. In all probability, it will be this design factor that will impose the practical upper limit on j_0 .

VIII. Effect of the Atmosphere on the Rocket during Departure

566

In departure, an important factor contributing to the rocket velocity surplus L is the resistance of the atmosphere, which, first of all, reduces the actual acceleration I of the rocket relative to the center of the earth

$(I = \overline{j_0 + g + j_p} = \overline{j + g})$ and thus decreases v , and, second, compels us to give the angle θ a value greater than zero in order to avoid too large a rocket velocity within the dense regions of the atmosphere, hence in order to avoid too large a value of L_d . However, increasing θ , according to equation (14), causes an increase in $L_{g\beta}$. Furthermore, we may be forced to diminish j and v over a certain initial segment of T_e in order to preclude catastrophic overheating of the surface of the rocket.

The effects of resistance from the medium and heating of the moving surfaces have been theoretically investigated only very meagerly, and there is almost no experimental material relating to velocities expressed in kilometers per second. Consequently, all that we might know beforehand about these effects is their approximate magnitude, determined on the basis of simplified laws governing the dependence of the drag and heating of the moving surfaces on their shape, slope angle and velocity of motion, as well as the density, chemical composition, and temperature of the medium. We cannot discuss the exact computation of these effects right now, because they are not amenable to such treatment, even for velocities at which variations in the density of the medium surrounding the body can be neglected. We will base our computations on the following equation, which in general is approximately valid:

$$Q = Skv_1^2 \Delta 10^{-4} c, \quad (15)$$

where Q is the drag force in kg, S is the cross sectional area of the body in m^2 , k is a proportionality factor, which, according to experimental data for velocities near the velocity of sound, where it is a maximum, is equal to 0.25; v_1 is the velocity of the body relative to the air in cm/sec (in our case, neglecting the wind, $v_1 = v - U$, where U is the velocity of rotation of the earth's surface), c is a coefficient depending on the shape of the body and equal to unity for a normally oriented plane, and $\Delta = \rho_h / \rho_0$ is the ratio of the atmospheric density at the position of the rocket at a given time to its value at sea level.

Since it has been more to our advantage to work with accelerations throughout the present article, rather than with the forces giving rise to them, in the present case as well we will go from the resistance of the atmosphere to the deceleration that it induces on the part of the rocket, denoting this deceleration by j_ρ . Expressing all quantities in absolute units, substituting $k = 0.25$, and introducing in place of S the transverse load of the rocket P , we obtain from equation (15)

$$j_\rho = 2.5 \cdot 10^{-3} \frac{c}{P} v_1^2 \Delta = k_1 v_1^2 \Delta, \quad (16)$$

where $k_1 = 2.5 \cdot 10^{-3} \frac{c}{P}$ (j_ρ in cm/sec^2 , P in g/cm^2 , v_1 in cm/sec).

In the resistance of the atmosphere and in the heating of the moving surface, we can distinguish two essentially discrete parts, which are the result of different factors: 1) resistance (drag) and heating due to the pressure of the medium on surfaces inclined at an angle with their trajectory; 2) resistance and heating due to viscosity of the medium as it slides along the moving surfaces. The first two effects are the outcome of adiabatic compression of the air ahead of the frontal surfaces of the body and adiabatic expansion of the air behind the rear surfaces. The second two effects are the outcome of internal friction in the medium as it slides along the surfaces of the body. For the first two effects, we will use the notation d_p and h_p , for the second two, d_v and h_v . Equation (16) applies only to d_p , which in general is proportional to the square of the velocity and the first power of the density, whereas d_v , in those layers of the atmosphere where the mean free path of the gas molecules is negligible in comparison with the dimensions of the moving body, is proportional to the one and one-half power of the velocity of the body and the square root of the medium density. Since, according to experimental data, d_p turns out to be larger than d_v for bodies that do not possess a particularly elongated

profile,³ at velocities of several meters per second in the sea level atmosphere, the drag d_v , which is less dependent on the velocity, will be made insignificant relative to the quantity d_p at the hundred- and thousand-meter per second velocities that the rocket will have even in the lower layers of the atmosphere (at the beginning of the path, the ratio $d_v/d_p = kv^{-1/2} \rho h^{-1/2}$ will decrease rapidly).

At altitudes of several tens of kilometers, the drag d_v , being less dependent on the density of air than d_p , can also be made a relatively appreciable quantity, but at such altitudes, due to the inconsequential density of the air, both d_p and d_v will no longer be significant in absolute value, in spite of the increasing velocity. The principal part of the total drag $d_s = d_p + d_v$ will therefore be d_p for about the first 30 to 40 km above sea level. In 568 order to formulate an overall approximate notion as to c and j_p , we will therefore confine ourselves to the theoretical investigation of d_p only.

The main factor representing atmospheric effects is the density of the atmosphere. If we regard the gravitational acceleration, chemical composition of the atmosphere, and its temperature as identical at all altitudes, its density will be a decaying exponential function of the height, which we can express with fair accuracy in a form suitable for approximate calculations as follows:

$$\rho_h = \rho_0 e^{-h/5} \quad (17)^4$$

³The cross section of the rocket must include the pilot compartment, consequently, it has a definite minimum of about 4 m^2 in area; the shape of the rocket, therefore, cannot be too elongated.

⁴ Assuming a constant temperature $t = -50^\circ\text{C}$, which is observed at altitudes above 10 km. Equation (17) is normally written $\rho_h : \rho_0 = e^{-h/7.2} = 10^{-h/16.5}$, where h is the altitude in kilometers above sea level, ρ_0 is the density of the atmosphere at sea level (noted by V. P. Vetchinkin).

There are no precise empirical data relating to the composition of the atmosphere at large altitudes, but, according to existing data, the temperature and buoyancy of the air as we move upward do not follow an adiabatic law, instead they fall off more slowly than adiabatic. This indicates that in the atmosphere there is a limit above which the intermingling ascending and descending air currents cannot penetrate. Above this upper limit of the atmosphere with its constant percentage composition, the partial densities of all the gases must no longer decrease proportionately on moving upward, but in conformity with their molecular weights; the percentage content, and according to the latest research the absolute partial density at certain altitudes, of the lightest component of the atmosphere - helium - must almost double every 5 km of height. This factor is in our favor during departure, if the takeoff is executed by means of airfoils (wings or fins) but will work against us when we discontinue the use of airfoils. In the first instance, this density would provide support for the airfoils (the problem of overheating of the surfaces can become acute only with respect to a nitrogen-oxygen atmosphere, of which more will be said below), while in the second case it would yield excess resistance to the motion of the rocket once it has developed considerable velocity. This resistance, however, cannot be comparable with the magnitude of the resistance of the lower, dense nitrogen-oxygen layers of the atmosphere. To gain a general notion as to the variation of j_p during departure, we will assume: $\theta_1 = \text{const}$ (the angle θ_1 corresponding to the velocity v_1 is the angle between the velocity v_1 and horizon plane; in departure upward and to the east, $\theta_1 > 0$); $I = \text{const}$; then

$$v_1^2 = 2 \cdot 10^8 I h \frac{1}{\sin \theta_1} (v_1 \text{ in cm/sec, } I \text{ in cm/sec}^2, h \text{ in km}). \quad [569]$$

The ratio $\rho_h / \rho_0 = \Delta$ is given in equation (17). Substituting the expression for v_1^2 from the foregoing equation and the value of Δ from equation (17) into equation (16), we obtain

$$\begin{aligned} j_p &= F(h) = k_1 \cdot 2 \cdot 10^8 h I \frac{1}{\sin \theta_1} 2^{-\frac{h}{5}} = \\ &= (\text{with substitution of } k_1) = 500 \frac{cI}{P \sin \theta_1} h \cdot 2^{-\frac{h}{5}} = k_2 h 2^{-\frac{h}{5}}, \quad (18) \\ \text{where } k_2 &= 500 \frac{cI}{P \sin \theta_1}. \end{aligned}$$

This function will be used to characterize j_p in terms of the height above sea level, assuming that the point of departure is situated at sea level; this is shown graphically in figure 3, for $k_2 = 10$; as it increases from 0 at $h = 0$, j_p assumes maximum values for $9 > h > 6$, then decreases, becoming similar in its behavior to the function $2^{-h/5}$. Integrating $F(h)$, we obtain the negative work done by the atmosphere on the rocket in dyne-kilometers per gram mass of the rocket:

$$\int_0^h F(h) dh = k_2 \left\{ \frac{25}{(\lg 2)^2} - \frac{5}{\lg 2} 2^{-\frac{h}{5}} \left(h + \frac{5}{\lg 2} \right) \right\};$$

$$\int_0^{\infty} F(h) dh = k_2 \left(\frac{5}{\lg 2} \right)^2 \approx 50k_2; (\text{dim: } 10^5 \text{ erg/g}).$$

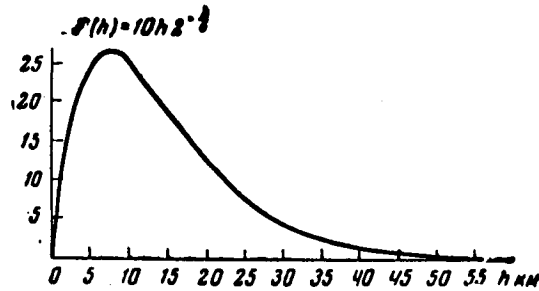

Figure 3

Replacing the factor h by $h - h_0$ in $F(h)$ and taking $\int_{h_0}^{h_0+h} F(h) dh$, which would 570 correspond to a transfer of the departure point to h km above sea level, we obtain values smaller by a factor of $2^{-h/5}$, hence the negative work on the part of the atmosphere, as well as the values of L_{dp} , are proportional to the density of the atmosphere at the point of departure. This law is valid for all trajectories which are identical in configuration and velocities and differ only in the altitude of the departure point. From this (and only from this) point of view, the altitude of the departure point is significant. But for the quantity w_e , this altitude is of relatively minor importance within the range of variation that we can possibly realize; thus, for example, moving the point of departure upward 10 km decreases w_e only by about 35 m/sec.

To find the value of L_{dp} , we must integrate j_ρ with respect to the time. Substituting $I \cdot t$ in place of v_1 in equation (16), expressing Δ in terms of h , and h , in turn, in terms of t and I , as $h = 10^{-5} \frac{1}{2} I t^2 \sin \theta_1$, we obtain

$$j_\rho = F(t) = 2,5 \cdot 10^{-3} \frac{cI^2}{P} t^2 2^{-10^{-4} I t^2 \sin \theta_1} = k_3 \cdot t^2 \cdot 2^{-10^{-4} I t^2 \sin \theta_1}, \tag{19}$$

where

$$k_3 = 2,5 \cdot 10^{-3} \frac{cI^2}{P}.$$

For the time variation, we will assume arbitrary data convenient for computation: $I = 5000 \text{ cm/sec}^2$ and $\theta_1 = 90^\circ$, whereupon

$$j_p = 62500 \frac{c}{P} t^2 e^{-0.0001t} = k_4 t^2 e^{-0.0001t} \quad (20)$$

where $k_4 = 62,500c/P$. The function $j_p = F(t)$ is graphically illustrated in figure 4 for $k_4 = 1/3$.

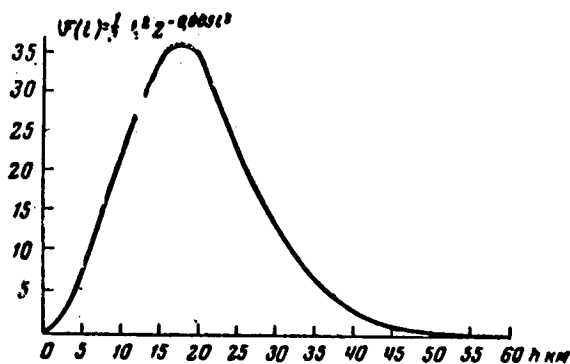

Figure 4

The value of $\int_0^\infty F(t) dt$ according to equation (20) (or L_{dp} for $I = 5000$ 571 cm/sec^2 and $\sin \theta_1 = 1$) is equal to about $2000 k_4$. It is readily seen that L_{dp} must be proportional to $I^{1/2}$ and $(\sin \theta_1)^{-3/2}$. Consequently, for any values of I and θ_1 we will have

$$\begin{aligned} L_{dp} &= 2000 k_4 \cdot \sqrt{I : 5000} \cdot \sin^{-3/2} \theta_1 = \\ &= 1,75 \cdot 10^6 \frac{c}{P} I^{1/2} \sin^{-3/2} \theta_1 = z \sin^{-3/2} \theta_1, \end{aligned} \quad (21)$$

where

$$z = 1,75 \cdot 10^6 \frac{c}{P} I^{1/2} = L_{dp} (\text{for } \theta_1 = 90^\circ).$$

The optimum angle θ_1 is that angle for which

$$L_{g\beta d} = L_{g\beta} + L_d = \min.^5 \quad (22)$$

We will assume for simplicity that $\theta_1 = \theta$, i.e., we will neglect the rotation of the earth about its axis. Then the angle θ_1 must satisfy the equation

$$z \sin^{-\frac{2}{3}} \theta_1 + w \frac{\sin \theta_1}{3j} = \min.$$

From this, we find

$$\sin \theta_{1\text{optim.}} = \left(\frac{9jz}{2w} \right)^{3/4}. \quad (23)$$

Inasmuch as we do not, in actuality, have to make $\theta_1 = \text{const}$ over the entire I_j , but since, on the other hand, we cannot vary it abruptly, especially at large velocities, since this would require a large angle β and large L_β , it follows that, according to equation (23), $\sin \theta_{1\text{optim}}$ can only be an average for a segment I_j lying within the appreciably dense portion of the atmosphere. At the beginning of this segment it is more favorable to take $\theta_1 > \theta_{1\text{optim}}$, then, gradually diminishing it, go over to $\theta_1 < \theta_{1\text{optim}}$, since this diminution can be achieved by the action of the force of gravity and a small deviation of the rocket axis from the trajectory (in order for L_β not to be large, it is necessary that $\beta \leq 5$ or 10°). For better penetration through the atmosphere and for obtaining the lowest possible L_d , the rocket should have a long, pointed configuration, and its discharge tube can only be aligned with the long axis. Consequently, along the segment of T_e on which L_d can attain sizable 1572 values, namely beginning with the point at which the rocket velocity v_1 attains values of several hundred m/sec and ending with an altitude of about 60 km, the long axis of the rocket, as well as the axis of the discharge tube and the direction of reaction, must be aligned with the direction of the trajectory

⁵ L_α , i.e., the surplus rocket velocity that depends on the opposing reaction of the supporting surfaces inclined at an angle α with respect to the trajectory, is not included here, as it is almost totally independent of the angle θ_1 .

in order to obviate excessively large atmospheric drag. Hence, the exhaust-reactive force component normal to the trajectory, being equal to $j_0 M \sin \beta$, and the angle β must be nearly zero; with this stipulation, unless some other normal force is acting on the rocket, the trajectory will curve under the influence of the normal component of the force of gravity, equal to $Mg \cos \theta$, where the radius of curvature will be equal to $\rho = v^2 / g \cos \theta$. For velocities $v < 2000$ m/sec and for θ not too near 90° , this curvature of the trajectory could cause the rocket to head back toward earth before it had managed to reach the atmospheric regions of negligible density, wherein the angle β may be given any value we like, without creating considerable atmospheric drag. A force to counteract the normal component of the force of gravity might be the air pressure on lifting surfaces, with which the rocket would be equipped. These would have to be steel surfaces covered with a thermal insulation (aluminum, probably, will probably be unsuitable due to its low-melting characteristic), extending along the body of the rocket and having a surface area such that their load will be approximately 200 kg/m^2 . At velocities beginning with $v_1 = 100$ m/sec, a small angle of attack (angle α between the lifting surfaces and trajectory of the rocket) will be sufficient ($\sin \alpha < 1/10$) in order for the lifting force developed by the supporting surfaces to equalize the normal component of the force of gravity and thus to prevent the rocket trajectory from curving downward more than is desirable. The opposing action of the surfaces (i.e., the projection of the force due to air pressure onto the rocket trajectory) will also be relatively minor, namely $Mg \cos \theta \tan \alpha$. It will decrease the translational acceleration of the rocket by an amount

$$g \cos \theta \tan \alpha = \frac{j \cos \theta}{j \cot \alpha}, \quad (24)$$

where, as the rocket picks up velocity, the angle α can be decreased (until the rocket enters the rarefied layers).

Considering $\alpha = \text{const}$ and $\sin \theta \ll 1$ (L_α can only have significant values for small slopes of the trajectory, i.e., for prolonged flight in the atmosphere), we have approximately /573

$$L_\alpha = \frac{w \tan \alpha}{3j \cos \theta} \quad (24a)^6$$

⁶ In this equation, as in equations (13) and (14), the factor 3 in the denominator is attributable to the following: 1) The surplus occurs in the interval in which the rocket develops only the first 8000 m/sec of its velocity, since beyond this point the rocket becomes a free body; 2) as the velocity builds up from 0 to 8000 m/sec, all drag effects decline to zero, since they are directly related to the apparent gravity of the rocket, but the latter quantity reverts to zero at $v = 7909$ m/sec at sea level with v in the horizontal direction.

under the condition that the (apparent) gravity of the rocket is inhibited the whole time only by the action of the lifting surfaces. The lifting surfaces are desirable for the initial development of velocity, if we have $2 < j_0 < 3$, and are always necessary for $j_0 < 2$, since for $j_0 = 2$, even for purely tangential flight, L_β amounts to about 600 m/sec, while for $j_0 = 1$, L_β would go to infinity if we were to try and counteract the weight of the rocket solely with the exhaust reaction. Nevertheless, it is quite possible that it will be difficult from the design point of view to create an initial value of $j_0 > 2$; in this event, then, the prolonged application of airfoils is mandatory. In our favor, in this case, is the fact that the ratio j_0/g_a (where g_a is the apparent gravitational acceleration of the vehicle (its weight minus the centrifugal force) will decrease steadily and fairly quickly, on the one hand because of the decrease in g_a as centrifugal force is developed, on the other hand because of a possible increase in j_0 as the mass of the rocket is diminished. Since, for a certain period of time after takeoff, all that functions is the one initial unit m_1 , we can maintain its absolute performance rating at the same level and thereby obtain an ever-increasing relative exhaust intensity dM/Mdt and, accordingly, increasing j_0 . Thus, for example, at the instant the rocket develops a velocity $v = 5000$ m/sec ($v_1 \approx 4500$ m/sec), its apparent gravitational acceleration will decrease by a factor of $5/8$, the mass by a factor of about $2/5$, so that, with the rest of the reaction force constant, j_0 will increase fourfold relative to g_a . This fact shortens considerably the period in which the airfoils are utilized, because they are more essential the nearer j_0/g_a is to unity, while for $j_0/g_a > 2$ we can get by without them altogether, counteracting the gravitational force on the rocket with the vertical component of the reaction force.

The theoretical investigation of the utilization of airfoils at velocities $v_1 > 1000$ m/sec is very difficult for lack of appropriate experiments and investigations, both with respect to the laws of drag and heating of moving bodies at high velocities and with respect to the composition of the atmosphere at heights of several tens of kilometers. If we were to rely on the data of modern aviation, the outlook for the use of airfoils would seem very promising. But, in all probability, at velocities several times the speed of sound, the drag as a function of the angle of attack approaches the Newtonian formula $F/s = k \sin^2 \alpha$, so that the lifting force of the supporting surfaces will be much less than according to the formulas used in aviation, their aeronautical efficiency falling off accordingly. Due to the reduction in lifting force coefficient at large rocket velocities, it would not be able to escape from the comparatively dense atmospheric layers before reaching a velocity of about 700 m/sec (at which the apparent gravity already begins to fall off sharply).

Consequently, it is necessary to pay special attention to the problem of the additional drag due to viscosity of the atmosphere d and heating of both the frontal portions of the rocket due to adiabatic compression of the air in front of it, and of the sloping surfaces due to the viscous forces. Therefore, leaving open the question of the possible limits of applicability of winged flight, we will consider that the rocket has a ratio $j_0/g_a > 2$ at the instant the rocket develops a velocity $v_1 = 4500$ m/sec. At the very inception of velocity buildup to 100 m/sec, we should make $\beta > 0$ if we wish to have $\bar{j} < 2$, otherwise the initial acceleration of the rocket will be executed by some mechanical means. In the first instance, the axis of the rocket would not at all coincide with the tangent to the trajectory, but at small velocities a certain deviation still would not produce too great a deceleration due to atmospheric drag.

The optimum rocket velocity at a given point of its trajectory, i.e., for given θ and h , is that velocity at which minimum L_s is attained for the element of the trajectory nearest this point. We have, consequently, the equation

$$L_s = L_g + L_d + L_\alpha = \min, \quad (25)$$

where in the functions L_g , L_d , and L_α we must take v_1 as the variable, assuming $\theta = \text{const.}$ ⁷ According to equation (10),

$$L_{ig} = ig \sin \theta \frac{1}{r^2 v} - ig \sin \theta \frac{1}{\omega r \sqrt{r}} \quad (26) \underline{575}$$

(since α in equation (10) is equal to $ig \sin \theta \frac{1}{r^2}$). The optimum velocity problem is of practical significance only for the segment near the earth's surface in the medium of a dense atmosphere, so that we can let $\bar{r} = 1$ with only minor error. According to equation (16),

$$L_{id} = t_j = \left(\frac{i}{v}\right) k_1 v_1^2 \Delta;$$

⁷The following computations, like the concept of optimum velocity itself, are only applicable so long as we have $\theta > \alpha$, i.e., so long as the opposing action of the force of gravity at a given point of the trajectory (projection of the gravitational force on the trajectory) is greater than the opposing action of the lifting surfaces, since at an angle θ small in comparison with the attack angle α , the altitude of the rocket at a given instant is directly dependent on its velocity at that instant and vice-versa, while the angle of ascent θ is determined by the way in which the velocity increases, so that the problem of finding an optimum velocity for a given altitude and angle of ascent becomes superfluous.

substituting here the value $v_1^2 = v^2 + U^2 + 2vU \cos \theta$, we obtain

$$L_{id} = vk_1 \Delta + i \frac{U^2}{v} k_1 \Delta + 2iUk_1 \Delta \cos \theta. \quad (27)$$

According to equation (24), we have

$$L_{i\alpha} = \left(\frac{i}{v}\right) g \cos \theta \tan \alpha \quad (28)$$

The third term in equation (27), like the second term in equation (26), does not contain v , hence is constant in this case. Substituting into equation (25) the values of L_{ig} , L_{id} , and $L_{i\alpha}$, excluding the constant terms, we obtain

$$\frac{i}{v} g \sin \theta + \frac{i}{v} U^2 k_1 \Delta + \frac{i}{v} g \cos \theta \tan \alpha + vk_1 \Delta = \min.$$

Solving this equation and substituting the value of Δ according to equation (17) and the value of k_1 from equation (16), we get

$$v_{\text{optim}} = \sqrt{2^{\frac{h}{s}} \cdot 400P \cdot g \frac{1}{c} (\sin \theta + \cos \theta \tan \alpha) + U^2}. \quad (29)$$

v_{optim} is the value of the velocity that should not be exceeded in flight, at any rate not exceeded by too great an amount. Should it happen that, for the I and θ that we have chosen on a certain ith segment, the rocket velocity turns out to be much greater than optimum for the given h and θ , I would have to be decreased at the beginning of this segment until the rocket had attained considerable altitude, at which v_{optim} is then made larger (equation (29)).

Substituting the value of z from equation (21) into equation (23) and neglecting the difference between j_0 and I (we can do this without dangerous error, since flight is possible in general only as long as the difference between j_0 and I is not too great, i.e., as long as L_s is not particularly great), we obtain

$$\sin \theta_{\text{optim}} = 0.14 \left(\frac{c}{P}\right)^{\frac{7}{8}} I^{\frac{1}{8}}. \quad (30)$$

Substituting this expression for $\sin \theta$ into equation (21), we obtain /576

$$L_{dp} = 1.75 \cdot 10^6 \frac{c}{P} I^{\frac{1}{8}} \left\{ 0.14 \left(\frac{c}{P}\right)^{\frac{7}{8}} I^{\frac{1}{8}} \right\}^{-\frac{7}{8}} = 34 \cdot 10^6 \left(\frac{c}{PI}\right)^{\frac{1}{8}}. \quad (13)$$

Substituting the value of $\sin \theta$ from equation (30) into equation (14) and again neglecting the difference between j_0 and I , we obtain

$$L_{g\beta} = \frac{w}{3I} 0,14 \left(\frac{c}{P}\right)^{1/5} I^{1/5} 981 = 5 \cdot 10^7 \left(\frac{c}{PI}\right)^{1/5} \quad (32)$$

Adding equations (31) and (32), we obtain $L_{g\beta d}$ as a function of the acceleration I , under the condition that the rocket follows a trajectory with an ascent angle $\theta = \arcsin \theta_{opt} = \text{const}$, and for $I = \text{const}$:

$$L_{g\beta d} = 84 \cdot 10^4 \left(\frac{c}{PI}\right)^{1/5} \cdot \quad (33)$$

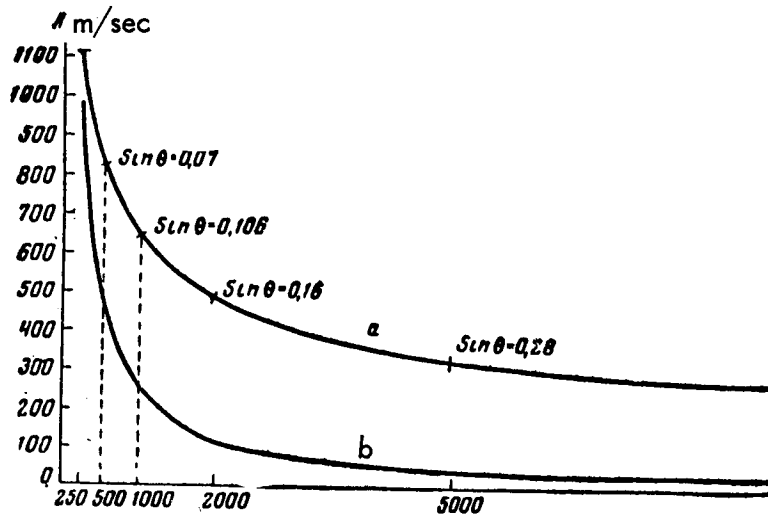

Figure 5

a) $L_{g\beta d} = 84 \cdot 10 (1/62,500I)^{2/5}$; b) $L_{\alpha} = (1,120,000/3I) \tan \alpha$
 (L in m/sec; I in cm/sec^2 ; $\tan \alpha = 0.1$).

A graph of this function (equation (33)) is given in figure 5 for $c/P = 1/62,500$ ($c = 0.04$, $P = 2500$, these values being approximately probable data). In the same graph is given the function

$$L_{\alpha} = F(I) = \frac{w \tan \alpha}{3I \cos \theta} \quad (24a)$$

where in the latter we neglect the divisor $\cos \theta$ (which in prolonged winged flight is necessarily very near unity) and, as in the preceding equations, we assume $I = j_0$. /577

The quantities $L_{g\beta d}$ from equation (33) and L_α from equation (24) cannot be added one to the other, since the assumptions underlying the derivation of these equations are mutually exclusive; if the prolonged use of airfoils (L_α) necessitated by small j_0 holds, then we cannot have $\theta = \text{const}$, but if j is large and $\sin \theta$ is correspondingly not too small, airfoils are not used continuously and we can have $\alpha = \text{const}$. In the first situation, we must orient more according to equation (24a), in the second situation, more according to equation (33); the changeover point is $j_0 \approx g$.

In the present section, we have permitted a number of simplifications (though always toward increased resistance; in particular, equating θ to the larger angle θ_1 , we increased the calculated loss in velocity $L_{g\beta}$, while taking the maximum value of the coefficient k in equation (15), we increased the calculated loss in velocity L_{dp}), and in equation (33) (see fig. 5) we introduced more or less probable yet nevertheless arbitrary data ($c = 0.04$, $P = 2500$), doing the same in equation (24) ($\alpha = 0.1$). With this in mind, as well as the fact that in departure at an angle $\theta_1 < 30^\circ$ (from all indications, θ_1 would never be greater than 30° in any case) the economy in W_e from utilization of the earth's velocity of rotation about its axis will amount to about 450 m/sec, we may regard the following as a safe result of the calculations in the present section: the required rocket velocity W_e , taking into account all resistance effects, will not be more than 12,000 m/sec and, in all likelihood, will be somewhat less.

As far as heating of the rocket surface is concerned, this problem will clearly not be as acute in departure, a fact which may be inferred from the following considerations:

Let us assume
$$p_v = 0.02 \rho v^2, \tag{34}$$

where p_v is the pressure in atmospheres in a plane moving perpendicular to itself at a velocity v in m/sec, ρ is the atmospheric density in g/cm^3 , v is the velocity in m/sec, 0.02 is the drag coefficient for the largest velocity investigated;

$$P_0 = 80 \frac{\rho T}{\pi}, \tag{35}$$

P_0 is the buoyancy of the atmosphere in atmospheres, T is the absolute temperature, 0 is the same as in equation (34), m is the molecular weight (mean) of the gases constituting the atmosphere. The adiabatic compression formula is

$$\frac{T}{T_1} = \left(\frac{P}{P_1}\right)^{\frac{k-1}{k}} \quad (36)$$

where $k = 1.41$.

Regarding heating as the result of adiabatic compression, we obtain for velocities $v > 700$ m/sec, at which $p_v \gg p_0$ (in an oxygen-nitrogen atmosphere; for other gases, the lower limit of applicability of the following equation is proportional to their molecular velocity):

$$T_1 = 0,09 T^{\frac{1}{k}} v^{\frac{k(k-1)}{k}} m^{\frac{k-1}{k}} = 0,09 T^{0,71} v^{0,582} m^{0,291} \quad (37)$$

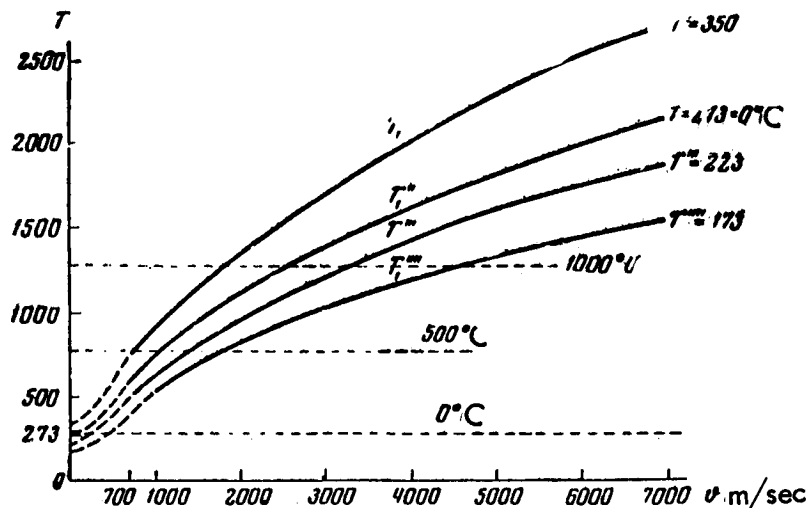

Figure 6. $T_1 = 0,09 T^{0,71} v^{0,582} m^{0,291}$; $m = 29,3$

A graph is constructed according to this equation for $m = 29.3$ (fig. 6). The equation gives the air temperature in front of a surface normal to the trajectory; this temperature will obtain only ahead of the frontal parts of the rocket, the nose and leading edges of the foils, while near sloping surfaces the pressure and corresponding temperature will be considerably less. If we protect the oncoming frontal regions with some kind of refractory material, the remaining external surfaces of the rocket, if made of steel, should be able to withstand velocities up to 4500 m/sec, even without special refractory

protection. Calculations of the temperatures of rapidly moving bodies are given below in section IX. Here we will use a second means of calculation - according to equation (37), but with allowance for the ameliorating circumstance that we do not make our surfaces normal to the trajectory but with a slight angle of attack, so that the air compression ahead of them, hence their temperature, will be still considerably lower. At the instant the rocket acquires a velocity of 4500 m/sec, it will be moving through the rarefied layers of the atmosphere, in addition to which (see page 92) there is no longer a need for airfoils. /579

The data are no less favorable if we proceed from the fact that dum dum bullets, charged with mercury fulminate, do not fly apart spontaneously in air, having an initial velocity up to 700 m/sec and being so small that they are able to heat up quite considerably during their flight. The detonation temperature of mercury fulminate is 185°C, wherefore it may be assumed that the bullets are not heated to more than 150° above the air temperature. We presume that the absolute temperature of the surfaces of a moving body is proportional to some power (x) of the mean (square) molecular velocity of the gaseous medium relative to this body. Then, knowing that the mean molecular velocity of air at 0°C is 460 m/sec, we determine the mean velocity of the same molecules relative to a bullet flying at a speed of 700 m/sec:

$$v = \sqrt{460^2 + 700^2} = 837 \text{ m/sec}$$

We formulate the equation

$$\left(\frac{837}{460}\right)^x = \frac{T_1}{T};$$

substituting $T = 300^\circ\text{K}$ and $T_1 < 450^\circ$, we obtain $x < 0.7$. Consequently, we obtain

$$T_1 < T \left(\frac{u^2 + v^2}{u^2}\right)^{0.35}$$

(where u is the mean molecular velocity, v is the velocity of the moving body).

According to this equation, with $v = 4500 \text{ m/sec}$, we obtain $T_1 < 800^\circ\text{C}$ for $T = 220^\circ\text{K} = -53^\circ\text{C}$.

IX. Extinction of the Return Velocity by Atmospheric Resistance

On returning to earth, we need to reduce the velocity of the rocket to zero; consequently, the resistance of the atmosphere will consistently work to our advantage, and our only task is to utilize it optimally without burning up the rocket from motion through the atmosphere at velocities of several km/sec. The resistance of the atmosphere has a twofold application: 1) to extinguish the entire return velocity $w_r = 11,185$ m/sec; or 2) to extinguish just the "circular velocity," which is

$$7909 \text{ m/sec} + \alpha = \frac{w}{\sqrt{2}} + \alpha,$$

where α is for the moment, lacking reliable information on the upper layers of the atmosphere, an indeterminate multiple of ten meters per second; the latter /580 is somewhat simpler technically; we will first consider the extinction of the last $7909 \text{ m/sec} + \alpha$. We will adopt the following as our starting assumption: The rocket moves along a parabolic or prolate elliptical orbit, the vertex of which is situated at a distance of 400 to 600 km from the earth's surface, Depending on how precisely we are able to control the direction of the rocket; we must not only guarantee that the rocket will not fall to earth, but that it will not be torn apart in the dense layers of the atmosphere. The subsequent conversion of the trajectory is executed in application to its tangential type, except in the reverse order of that shown in figure 1. As soon as the rocket is in the segment of closest approach, it imparts deceleration to itself, reducing the eccentricity of the orbit and remaining at approximately the position of closest approach. When the eccentricity is diminished enough that it can no longer be detected by the pilot, the rocket will continue to impart small decelerations on arbitrary segments of its almost circular orbit. Each deceleration must be so slight that the resultant eccentricity will be barely noticeable; after each deceleration, the orbit is again traversed (the time to circle the earth is $1\frac{1}{2}$ hr) and, in the event an appreciable eccentricity is detected, it is corrected by a slight deceleration on the segment of closest approach. In this way, the orbit of the rocket will be continually narrowed, consistently maintaining its circular pattern, insofar as permitted by the error of detection. This constriction continues until the orbit is in atmospheric layers of such density that j_p attains a value of about 0.1 cm/sec^2 . From this moment on, the rocket ceases to function as such, and all objects of the proportional passive load are ejected. The construction of the rocket by this time should be as follows (see fig. 7): 1) pilot compartment; 2) an elliptical lifting surface, the design of which will be discussed below; the major axis of the ellipse should be perpendicular to the trajectory, the minor axis inclined at an angle α (about 40°) yielding the maximum lifting power; 3) a long tail section emerging from the pilot compartment to the rear at an angle α with respect to the minor axis of the elliptical lifting surface; at the end is a tail in the form of two plane surfaces forming an included angle of about 60° , its edge parallel to the major axis of the elliptical lifting surface and its bisecting plane parallel to the trajectory; 4) a surface for automatic maintenance of lateral stability, in the form of an angle similar to the tail but with less opening (about 45°), located above the pilot compartment and having its edge

perpendicular to the trajectory and edge of the tail. This surface automatically maintains lateral stability of the vehicle by turning to the right and left 581 about its edge under the control of a gyroscope located in the pilot compartment. The axis of the gyroscope is fixed beforehand parallel to the axis of

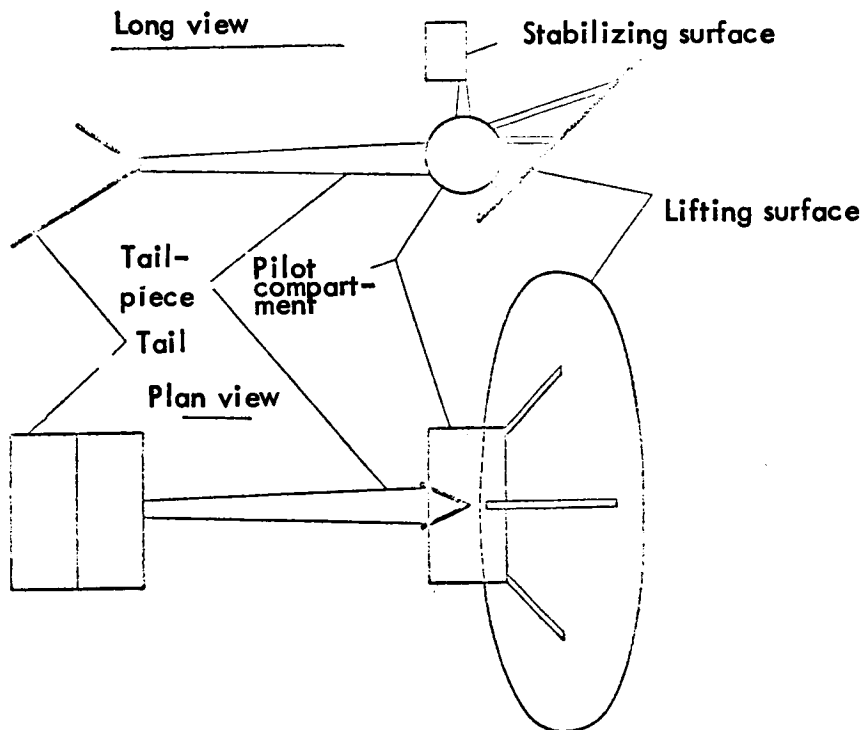

Figure 7. Diagram of a Vehicle for Suppressing the Return Velocity by Atmospheric Resistance.

earth's rotation. It is probably not feasible to achieve lateral stability of the vehicle at very large velocities in the rarefied layers of the atmosphere by purely aerodynamic means, wherefore some kind of automatic control device will be needed, such as the one indicated above. All of the indicated external parts should be carried aboard the rocket in disassembled form and assembled at the instant the orbit, or the part of it nearest the earth, passes through significantly dense atmosphere. A gliderlike vehicle of the above construction (differing from the glider by its much greater angle of attack, tail construction, and lateral stability mechanism) will have the attribute of always remaining in atmospheric layers of such density that, at its present velocity, the vertical component of the air pressure on the lifting surface will be equal to the apparent gravity of the vehicle, i.e., the surplus of its gravity over 582 the centrifugal force that it develops will be equal to

$$K = gM \left(1 - \frac{2v^2}{w^2} \right) \quad (38)$$

(horizontal motion along the arc of a large circle is assumed). As the velocity of the vehicle decreases due to the retarding effect of the atmosphere, it drops into the denser layers of the atmosphere, maintaining the balance between the apparent gravity and lifting force developed by the lifting surface. If we assume that the vehicle executes its return in the equatorial plane in an easterly direction ($v_1 = v - U$) and that the load on the lifting surface is equal to p kg/m², then, according to equations (15) and (38), we have

$$p \left(1 - \frac{2v^2}{w^2}\right) = K \cdot 10^{-4} (v - U)^2 \Delta c_\alpha, \quad (39)$$

where c_α is a function of the slope angle of the lifting surface. The left-hand side of this equation represents the apparent gravity of the vehicle per square meter of lifting surface, the right-hand side is the vertical component of the atmospheric resistance, i.e., the lifting force per square meter. On the basis of this equation, with $p = 200$ kg/m², $c_\alpha = 0.7$ ($\alpha = 40^\circ$), and $k = 0.1$

(we choose the smaller of the experimental values of k , being the less favorable, in lieu of data relating to such high velocities), we draw a graph of the function $h = F(v_1)$ according to equations (39) and (17) (fig. 8). The figures given with the curve denote the ratios $\Delta = \rho_h / \rho_0$ corresponding to the values of v_1 plotted on the horizontal axis. The part of the curve for $v_1 < 1000$ m/sec, is not plotted, since it is of no importance as far as we are concerned, for reasons discussed below. Extinction of the return velocity by atmospheric resistance is possible so long as the vehicle does not burn up in the air like a meteor at the values of v and h that will be encountered during descent according to equation (39); let us examine this condition: Inasmuch as the amount of heat given off (primarily through radiation) by the lifting surface of the vehicle at the highest temperature that it can withstand will not be

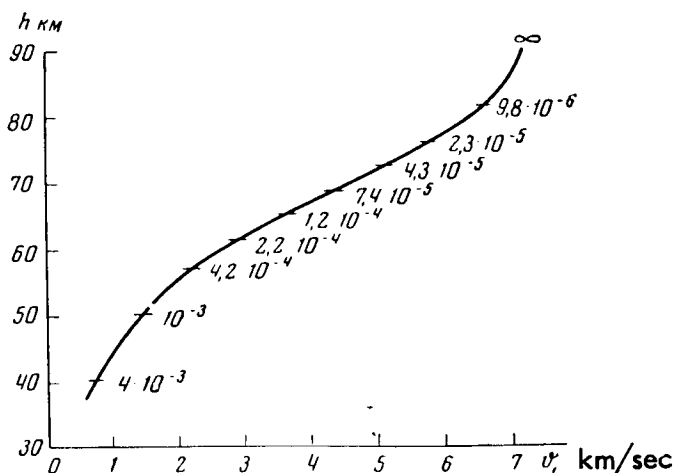

Figure 8. The Numbers on the Curve Denote the Ratios $\Delta = \rho_h / \rho_0$ Corresponding to the Values of v_1 Plotted on the Horizontal Axis, h is Computed from the Values of Δ According to Equation (17).

less than the amount of heat it acquires from the volumes of air in front of it, which is heated to incandescence by adiabatic compression, given different combinations of v and h corresponding to equation (39). We cannot formulate an exact notion as to the indicated phenomena for the lack of precise information on the effects occurring in an elastic medium near a moving body or on the radiative power of gases at temperatures of several thousand degrees. Since the radiation intensity increases as the fourth power of the absolute temperature, the surfaces of the vehicle supported by the atmosphere, above all its lifting surface, must have the greatest heat resistance, which means increasing their weight per square meter p . The most logical construction for the supportive tail and stabilizing surfaces is the following: a metal framework, thickly coated with a tile of some highly refractory material, as, for example, graphite, retort carbon, limestone, or porcelain. The tile should be on the side of the surface facing forward, so as to protect the metal frame. The parts of the frame coming in direct contact with the tile should be made of one of the higher-melting metals, the base of which might be tubular steel cooled from within by water and steam (the hazardous period of the descent will last less than 20 min) and protected against radiation from the back side of the tile by a porcelain lining. There is clearly no danger of considerable scorching of the carbon-bearing tile, because when the vehicle is traveling at a speed of several km/sec only the molecules of a very thin adjacent air layer will come into direct contact with its surface. The total amount of air in the volume described by the contour of the vehicle will only be a few times the mass of the vehicle as the latter decelerates from $v_1 = 7000$ m/sec to 2000 m/sec (hazardous interval). It is very probably that at altitudes $100 > h > 50$ km, the atmosphere is very impoverished of oxygen, whose molecular weight is higher than the molecular weight of nitrogen, and the hazardous velocities will occur at heights $100 > h > 50$ km. /584

In view of the fact that the hazardous velocities are several times the velocity of sound in air, only the surfaces of the vehicle facing forward will be exposed to the intense action of the atmosphere, while near the backward-facing surfaces will be almost complete void in comparison with the density of the surrounding atmosphere. In particular, the metal frame of the surfaces and the entire pilot compartment will be located in this void if properly constructed; the compartment should only be protected against radiation from the back side of the tile.

An approximate comparison of the possible quantities of heat liberated and gained by the lifting surface seems to indicate that the vehicle can return comfortably to earth, extinguishing the return velocity beginning with $v = 7909$ m/sec $= w/\sqrt{2}$. The work done by the vehicle on the atmosphere (independently of the inaccurate equations (17) and (15)) attains a maximum of Q , equal to about $3 p 10^{11}$ erg/sec per square meter of lifting surface, with V_1 equal to about 4500 m/sec. Less than half of this work will be dissipated in one direction by the lifting surface: $Q_1 > 1.5 p 10^{11}$ erg/sec, whereas the other, larger part will be radiated by the compressed volumes of air in the other direction - into space; if we assume that during the passage of air alongside

the surface of the vehicle (in the most hazardous period of flight this time will not be more than 0.002 sec), it will radiate a part of its heat, equal to qQ , where Q is the total amount of heat acquired by it in compression, then the lifting surface will acquire at most

$$qQ_1 < 1.5 p q 10^{11} \text{ erg/sec} \quad (40)$$

of radiative energy.

According to the Stefan-Boltzmann law, the radiation intensity from a complete black body is equal to $0.57T^4$ erg/sec per square meter of surface. We use a black body here, since in the foregoing case we assumed total absorption of rays by the lifting surface; affecting absorption and radiation identically, the absorption coefficient is of no importance for our purpose. If we let $p = 200 \text{ kg/m}^2$, which is a representative and probable figure, and $T = 3000^\circ\text{K} = \underline{585} = 2730^\circ\text{C}$ (a value near the maximum possible temperature), it turns out that the radiation power per square meter of lifting surface could attain a value of $9.2 \cdot 10^{13}$ erg/sec in both directions, whereas the absorbed energy will not be more than $3 \cdot 10^{13} q$ erg/sec (eq. (40)). Judging from the fact that the gases in the cylinders of internal combustion engines, during a period on the order of 0.1 sec, are only able to give up half of their heat to the cylinder walls, we are safe in assuming that the ratio q has a value expressed in less than hundredths. We therefore obtain a very large allowance for reducing $T = 3000^\circ\text{K}$ and for increasing the surface load $p = 200 \text{ kg/m}^2$.

We now present an alternate calculation of the temperature of the lifting surface. According to equation (37), at a velocity of 4.5 km/sec (we choose this velocity as the one yielding maximum work due to friction), the temperature of the air compressed adiabatically at an initial temperature of 0°C is $T_1 = 1800^\circ\text{K}$. Since the lifting surface absorbs thermal radiation in one direction, whereas both sides radiate energy, and since the amount of heat radiated must be equal to the amount absorbed, we have the relation

$$aT_1^4 = 2bT_2^4,$$

where a and b are coefficients proportional to the absorption coefficients of the heated gases and lifting surface, T_2 is the unknown temperature of this surface. Assuming $a = b$ and substituting $T_1 = 1800^\circ$, we find $T_2 = 1500^\circ = 1227^\circ\text{C}$. Actually, the absorption coefficient for a solid will be higher than for a gas, so that T_2 should be even less. It follows from the preceding calculations that the lining of the lifting surface can be made of porcelain or corundum tile.

After the velocity of the vehicle drops to $v_1 = 2000$ m/sec, any danger from overheating will be eliminated (see eq. (33) and fig. 5).

Further loss in velocity takes place just at the moment the vehicle is found at an altitude of one or two kilometers above the earth's surface level. Since we are unable to calculate precisely beforehand the position of descent and since it will be impossible to know beforehand in the first flights whether to land the vehicle on the ocean or dry land, a direct landing on the surface of the earth at the velocity v_1 , which is equal to several multiples of ten m/sec, would present danger to the life of the pilot; the vehicle should therefore be equipped for descent by parachute. If it proves convenient to carry a parachute of sufficient areal span, it can be used to bring down the entire vehicle; but if such a parachute is too bulky, then one will have to be devised for just the pilot, letting the vehicle make a separate landing. /586
If the descent is made over the ocean, landing can be made directly on the water. In this case, the steepness of descent and, hence, the abruptness of landing should be minimized ahead of time at altitudes of 10 to 20 km by decreasing the angle of attack of the lifting surface by rotating the tail section downward through some angle. The landing speed (horizontal) will thus be increased, but the impact will be diminished. For the case of maneuvering in air, which is necessary for descent onto the ocean, the tail section or tail itself must be steered by controls in the pilot compartment. Considering the possibility of descent over the ocean, the vehicle must be provided with whatever is needed staying afloat; it should have a sail, equipment for imparting stability on the water, if this is necessary, a small fuel supply in the form of compressed marsh gas (methane), and a lightweight low-power motor.

With these means, utilizing the tradewinds, the vehicle should reach the nearest land in a reasonable period of time, unless it is picked up earlier by some ship. To facilitate floating, the lifting surface and other similar parts should be ejected or disassembled and packed into the compartment. To extinguish the total return velocity by atmospheric resistance, the initial status should be the same as in the first case (see page 100); the control of the rocket is also the same as before, with the additional fact that its lifting surface has a variable angle of attack from $+40^\circ$ to -40° and is furnished with an automatic mechanism, which orients it in a positive angle of attack when the rocket enters the deeper layers of the atmosphere, at zero angle when the rocket flies parallel to the earth, and at a negative angle when, moving away from earth, the rocket flies into more rarefied layers of the atmosphere. This mechanism can be regulated by a control cable from a special fin situated on the outside perpendicular to the motion of the rocket. When the encountered atmospheric pressure increases on this surface, the mechanism should operate in one direction, imparting a positive angle of attack to the lifting surface; when the pressure diminishes it should operate in the opposite direction. In order not to subject the back side of the lifting surface to the action of the atmosphere, it may be possible, instead of imparting a negative angle of attack, to induce the entire rocket to rotate about its longitudinal axis. Cautiously, with small decelerations at the maximally distant point of the initial ellipse, the orbit of the rocket is constricted, the point of closest approach finally entering the confines of the significantly dense atmosphere. This entry should

take place at a distance from the earth's surface such that the rocket will operate with guaranteed safety, with allowance for possible control errors and errors in determining the data of its orbit, against overheating at velocities up to 11 km/sec. Also depending on this requirement is the choice of dimensions for the axis of the initial ellipse; the smaller the major axis, the greater will be the accuracy with which the point of closest approach to the earth can be calculated and the more delicate will be the approach to it (in particular, such that the perturbing influence of the moon will be minimized,) but, clearly, the greater will be the part of w_v that must be preliminarily extinguished purely by the function of the rocket. At the instant the segment of closest approach enters the rarefied layers of the atmosphere, the rocket begins to follow a trajectory completely analogous to the trajectory of the preliminary (external with respect to the atmosphere) phase of the return flight in extinguishing the velocity $w/\sqrt{2} + \alpha$ prior to the transition into circular orbit (see page 100), the only difference being that deceleration will not be provided by the action of the rocket on the segment of closest approach, but by the resistance of the rarefied atmospheric layers, which the rocket will pass through several times with an ever-diminishing major axis on the part of its orbit. /587

The automatically varied angle of attack of the lifting surface will play the following role in this operation. On penetrating deeper into the atmosphere, when the pressure on the control surface increases the angle of attack will be positive and the lifting surface will function to prevent the rocket's approach to earth, maintaining it in atmospheric layers rarer than the rocket would otherwise penetrate. When the rocket begins to emerge from the atmosphere and the pressure on the control surface diminishes, the angle of attack becomes negative and the lifting surface prevents the rocket from moving away from earth, thus emerging from the atmospheric layers at a smaller angle, so that the next entry therein is at a smaller angle and so that the penetration into the atmosphere on the next pass of the segment of closest approach is shallower. Consequently, by means of a variable angle of attack on the part of the lifting surface, it is possible to move the segment of closest approach away from the earth into more rarefied layers of the atmosphere, beginning with the first entry of the orbit into the significantly dense part of the atmosphere and continuing until the rocket goes over, as the result of the slowing action of the atmosphere, into a circular (essentially spiraliform) orbit contained entirely within the atmosphere, after which the remainder of the descent is executed exactly as in the case when the return velocity is extinguished by atmospheric resistance according to the first method.

Thus, by the second method, we extinguish 11,185 m/sec - β instead of 7909 m/sec + α by atmospheric resistance, where β is the amount of rocket deceleration expended in transition from T_c to the initial ellipse and entry of the point of closest approach of the initial ellipse into the confines of the atmosphere; β is a quantity which theoretically can be as small as we like and essentially is determined by the accuracy with which the rocket can be controlled and its orbit data computed. Approximately speaking, considering the thickness of the atmosphere to be insignificant in comparison with the radius of the earth, /588

$$\beta = \sqrt{2 \frac{R}{r_1} Rg} \left(1 - \sqrt{\frac{r}{r+r_1}} \right) + \sqrt{2 \frac{R}{r} Rg} \left(\sqrt{\frac{r_1}{r+r_1}} + \sqrt{\frac{R}{R+r}} \right),$$

where R is the radius of the earth, r_1 is the distance from the center of the earth to the point of closest approach (perigee) of the initial ellipse, r is the corresponding distance of the point of farthest approach (apogee). The first term represents the rocket deceleration necessary for transition from T_c to the initial ellipse; the second term is the deceleration required for entry of the initial ellipse perigee into the atmosphere. If we assume as approximate data $r_1 = 2R$ and $r = 20R$, we obtain approximately $\beta = 0.05 \sqrt{2Rg} = 0.05 w =$ approx. 550 m/sec. Consequently, we can utilize atmospheric resistance to quench a portion of w_v equal to 10,360 m/sec, and W becomes equal to about 12,550 m/sec.

X. An Interplanetary Base and Rocket-Artillery Device⁸

Velocities less than half the exhaust velocity u generated by whatever chemical compound is employed, i.e., up to about 2500 m/sec, overlooking the petroleum-air group (see page 64), can be developed more economically from the viewpoint of fuels and materials expended (in the objects m_1) by artillery means, but man is totally unequipped to take artillery type accelerations. It would be desirable, therefore, to deliver cargo and all objects of the passive load capable of withstanding accelerations of several thousand m/sec² (with suitable packaging, everything except delicate instruments) into interplanetary space by a rocket-artillery device, separately from the human passengers. With the rocket-artillery transportation of loads into space, we would economize as much as 50% on charge materials.

The difficulty of such a device lies in the problem of locating such a relatively small body in space as a rocket vehicle fired from earth. Looking ahead to the time when flights will be made more or less regularly, we propose the following technique for organizing them and arranging them so as to yield considerable material economy. 589

A rocket of large mass is sent from earth with a supply of active load for the development of a velocity W of about 12,000 m/sec. The final mass M_f of

⁸The author, unfortunately, did not have on hand a manual giving the optical power of modern telescopes, and it must be remembered that the problem of signalization with a "rocket-artillery device" has to be developed on the basis of data that are not quite reliable.

this rocket, due to the smaller required W , will be $\sqrt{n_1}$ times the final mass that the rocket could have if it had the same mass M_0 but designed for flight with a return trip to earth without absorbing the return velocity by atmospheric drag. This rocket then becomes a moon satellite with as large an orbit as is possible without succumbing to the hazard of being drawn back to earth, after which it unfolds a large signaling surface of material with a large visible-light reflecting power in relation to its weight per square meter. The unfolded surface may be as much as a hundred thousand square meters in area, since with a material thickness of 0.1 mm and absolute (bulk) density equal to unity, it would provide exactly $10,000 \text{ m}^2$; this surface will be freely discernible and locatable from terrestrial observatories. Near this signal surface there should be set up an interplanetary base for flights throughout the solar system. The realization of this base, irrespective of its rocket-artillery equipment, will provide the enormous advantage that we will not have to transport materials, instruments, machinery, and personnel with accessory compartments from earth into space and back again on every single trip, just as we will not have to discard objects of the first categories just to avoid the expense of transporting them back to earth. All of this will be stored on the base, whereas flights from the base to anywhere and back again will require $1/\sqrt{n_1}$ times the material expenditure that the same trip from earth would require. Rockets will be sent from earth into interplanetary space only to equip and supply the bases and to alternate the personnel staff after fairly prolonged periods of time. If rocket-artillery transportation proves feasible, then, above all, we will obtain about a 50% savings by setting up the equipment on a base in interplanetary space.

The base should initially have the following items:

- 1) Personnel - a minimum of three men with a chamber for themselves and everything needed for their sustenance.
- 2) A powerful telescope (a reflector, as possibly being more lightweight with the same diameter).
- 3) A small two-man rocket with a store of charge for developing $W = 2000 \text{ m/sec}$ and two telescopes of successively smaller power but larger field of view than the large base telescope.

In order to preclude rocking or oscillation of the base, which could /590 interfere with observations in a large astronomical instrument, its mass should be divided into four parts, arranging them at the vertices of a tetrahedron and joining them with aluminum girders (these girders are not required to have great strength or, consequently, large mass, since there will be no external forces acting on the base and the gravitational force on it will not be of consequence). So constructed, the base will have an incomparably larger moment of inertia relative to any axis and a correspondingly larger stability in space. Should the personnel be adversely affected by continued absence of an apparent gravity, only a compartment for telescope observations need be connected with

the described tetrahedron, and the living quarters could be constructed separately and attached by a cable several dozen meters in length to a counterweight. If to this system rotation is imparted about a common center of gravity, a centrifical acceleration will be created, which will be perceived just as gravity on the earth. In order to provide the living quarters with as much space as possible for the same mass, the air pressure inside it must be minimized insofar as possible. Experiments will have to be conducted toward this end, in order to evaluate the habitation of less dense air than that which we breath, but with a higher oxygen content.

Communication from earth to the base is effected by light signals, using a high-powered projector with a low scattering angle, set up on earth at a place known to the base; the signals from this projector must be detectable by the large base telescope. The base can communicate with the earth by means of a lightweight metal reflector of large area,⁹ aimed so that the sun's rays will be reflected toward some observatory on earth. The area of this reflector should not be too large for the signals to be observable in a large telescope.

The rocket-artillery delivery of cargo to the base is carried out as follows.

On command or at a preappointed time, a rocket-vehicle is fired from a cannon on earth, of which more will be said below, carrying equipment supplies for the base. The flight of the rocket-vehicle is computed so that it will land on the base; inasmuch as such precision is not actually possible, the path of the rocket-vehicle will pass a thousand or hundred so kilometers from the base. The relative velocity of the rocket and base at the instant of closest approach must be minimized, hence the instant of closest approach must coincide with the instant of maximum distance between earth and the base. The orbit of the rocket-vehicle relative to the moon should be hyperbolic with as small an angle as possible between the asymptotes. From the moment the rocket-vehicle is fired, light signals are sent out automatically and periodically, possibly by detonations of a mixture of magnesium and saltpeter. The period from one signal to the next should be such that the rocket-vehicle cannot escape from the field of view of the large base telescope during the interim, because once the vehicle is lost from sight, to find it again would be impossible except as a matter of pure luck. After the rocket-vehicle traverses its segments I_j , it automatically unfolds a signal surface of lightweight white fabric, similar to the base signal area. From the instant of firing, the large base telescope, which is aimed beforehand toward the point from which the firing is to take place, does not let the rocket-vehicle stray from its field of view, tracking it by its light signals on the interval I_j , then by the signal surface.

Shortly before the rocket-vehicle makes its closest approach to the base, when the rocket first becomes clearly discernible in the larger of the two telescopes on board the small base rocket, the latter is sent out to meet the

⁹ A rational construction for the reflector would be a thin planar reflective metal sheet stretched out over a lightweight metal Duralumin skeletal framework.

rocket-vehicle, reducing its velocity to zero as it approaches, attaching to it, and towing it to the base, using the charge available on the rocket-vehicle if necessary.

Because the rocket-vehicle necessarily carries certain instruments and mechanisms which, in their assembled form, could not favorably withstand accelerations of several ten thousand m/sec^2 , the cannon for firing the rocket-vehicle must be of considerable length, approximately 2 km. With this length, the required acceleration can be reduced to approximately 100g. Specially designed mechanisms can tolerate this kind of acceleration. The cannon could be a tunnel built in solid rock; in order to render the motion of the vehicle perfectly straight, the entire length of the tunnel should be fitted in quadrants with four carefully aligned metal guide strips, whereas the finishing of the intermediate regions can be fairly coarse. Owing to the considerable length of the cannon and the correspondingly low pressure of the gasses therein, compared with present-day artillery pieces, and owing to its large cross section, the burst of escaping gases through the 1 or 2 mm gap between the tunnel walls and vehicle will not be appreciable in comparison with their total quantity.

XI. Control of the Rocket, Measurement and Orientation Instrument

1592

For control of the rocket and orientation (navigation), the ship must have the following instruments:

1. An indicator of the apparent gravity inside the rocket, designed on the principle of spring-loaded weights with a suspended load; the indicator pointer will read the value of the apparent gravity directly. To the indicator should be attached a rotating drum for permanent recording of the readings. The area bounded by the resultant curve will be expressed by

$$\int_0^t (j_0 - j_p) dt = W - L_d.$$

This indicator should be connected to an automatic exhaust intensity control, so that the acceleration I_0 on the interval I_j will maintain the required value (equal to I_{max}). There should be two such indicators: one for the large accelerations up to and including I_{max} , another for small accelerations, from 0.01 to 10 cm/sec^2 . The first indicator will serve for departure on I_j and throughout the remainder of the flight, the second for entry of the rocket orbit into the atmosphere on the return trip. It would be unsuitable to measure accelerations of 1000 cm/sec^2 and decelerations of 0.01 cm/sec^2 on the same instrument.

2. An indicator of atmospheric resistance, in the form of a plate projecting externally from the rocket, connected by cables with the interior of the rocket. Due to friction in the linkages, such an instrument for determining

atmospheric resistance will not be used in place of the first type of indicator at the beginning of entry into the atmosphere, because it could have sufficient sensitivity.

3. An indicator of the rocket mass, giving readings that depend on the readings of instruments for taking into account the expenditure of charge. Connecting the second and third indicators, we obtain an indicator of the deceleration associated with the force of atmospheric drag. Connecting this indicator with the first, we obtain an indicator of the intrinsic rocket acceleration of the rocket j_0 ; integration of the latter record yields the magnitude of the velocity developed, W .

In order to automatically prevent the rocket from rotating about its own axis, which can happen as the result of insignificant, random errors in the construction of the rocket, it should have a gyroscope whose axis is aligned perpendicular to the axis of the rocket. The axis of this gyroscope should be free and able, by its movements relative to the body of the rocket, to control rotating surfaces which are inserted in the exhaust stream. In order to im- 593
part automatic stability or an automatic preset rotation of the longitudinal axis of the rocket, the latter should be equipped with a second gyroscope whose axis is parallel to the rocket axis and which controls other rotating surfaces placed in the exhaust stream.

For orientation of the pilot, special types of astronomical instruments and techniques need to be developed so as to achieve the most rapid and precise determinations of the position of the rocket and data relating to its orbit relative to the earth. These determinations are of utmost importance and require extreme precision just before attenuating the return velocity by atmospheric resistance. In order to impart greater stability to the axis of the rocket during free flight in empty space, procedures similar to those indicated on pages 107 to 109 may be instituted.

XII. The General Outlook

The essential factor governing the future potentials of space travel, at least in its first exploratory phase, is the amount of passive load, i.e., n , since this quantity dictates the economic aspect of the matter, which theoretically does not present any real difficulties. The amount of charge, or fuel, so to speak, and hence the approximate cost of flight (utilizing the object of the proportional passive load, (see page 72)) are proportional to the quantity $(n - 1)$. In the table (pages 64 to 66) are given the values of n corresponding to the total calorific value of various chemical compounds and rocket velocities $W_1 = 22,370$ m/sec and $W_2 = 14,460$ m/sec. The first velocity corresponds to flight from the earth into interplanetary space and back again without quenching the return velocity by atmospheric resistance, the second corresponds to the same flight with quenching of the last 7900 m/sec of velocity by atmospheric resistance. Until suitable experiments have been done, we cannot know what the rocket's performance will be, nor do we know just what chemical compounds or what percentage proportions of the latter will prove most suitable to use. Right now, we will use for our approximate calculations an average efficiency value of 0.8 for the total flight, this being a fairly probable value, according

to conjectural computations, which we will not give here, as well as data on the power developed by heated gases in internal combustion engines. We assume 3.3 kcal/g as an average value of the total calorific value. With these data, we obtain $u = 4700$ m/sec (note 15); this hypothetical value of the exhaust velocity, given the present lack of opportunity to gain a more dependable value, will be used as the basis of the ensuing calculations, assuming that the error in calculating n does not exceed the factor $n^{1/10}$ in either the plus or minus direction. In view of the relative insignificance of the velocity L_s , as explained in section VIII, we will let $W_e = 12,000$ m/sec, neglecting differences for which the value and even the sign are not known and which will most likely be in our favor (section VIII, page 99).

With these data and with the mandatory requirement for utilization of the objects m_1 (in the event that it is necessary to use a multiunit system; see section V) for purely rocket-powered flight from earth into interplanetary space and return to earth without quenching the return velocity by atmospheric resistance, we obtain from equation (4) $n = 120$, i.e., about 120 weight units of fuel per weight unit of payload, a significant part of the former being in the form of liquid oxygen or ozone, the remainder in the form of liquid CH_4 , C_2H_2 , SiH_4 , BH_3 , as well as one, not too minor portion, equal to $q\mu$, in the form of metal (mainly Duralumin) objects of the highest quality, namely the objects m_1 . The cheapest petroleum compound of the charge will also be of use, but this advantageous (despite the required increase in mass of the charge) use is severely limited by the fact that, corresponding to the increased charge mass, the mass of the most expensive of the expendable portions of the rocket - m_1 , the proportional passive load - must also increase. For a flight under the same conditions and with the same data, with stopover on the moon, $n = 1000$, or the same with stopover on Mars, $n = 3000$ (using the tangential type of trajectory, continued until the required hyperbolic velocity relative to earth is acquired). The latter figures can be reduced somewhat favorably by the advantageous use of more expensive and thermally efficient compounds - of the boron and borohydride types. It would be impossible to regard such potentials as satisfactory; each flight would require tremendous expenditures of material, and the possibility of taking along such heavy loads, materials, and machines would be completely lacking, due to the same economic aspect of the problem. Even the transportation of a large modern astronomical instrument would require colossal expenditures.

The key to the actual conquest of outer space is contained in the following: first of all, extinction of the return velocity by atmospheric resistance (section IX), then the building of an interplanetary base (section X) and, if it can be done, the necessary light signaling and artillery rocket transportation of supplies to the interplanetary base. The extinction of the return velocity by atmospheric resistance according to the first method, diminishing W to 14,460 m/sec, provides a sixfold reduction in n for all flights: from earth into interplanetary space and back, $n = 20$; the same with stopover on the moon, $n = 160$; the same with stopover on Mars, $n = 500$. With extinction by the

second method, when we have $W = 12,500$ m/sec, a 12-fold reduction in n is obtained, whence we have $n_e = 10$, $n_m = 80$, $n_M = 250$, respectively (note 16). The reduction in n in this case can be compared favorably with the use of cheap 595 petroleum compounds in large relative amounts in the charge or with a smaller' consumption of objects from the proportional passive load as charge.

For the same flights from an interplanetary base, we would have values of n reduced still more by a factor of 1/11: $n_e = 2$ (return from the base to earth); with n so near unity, we no longer ignore the difference between n and $(n - 1)$; $(n - 1) = 1$ in this case, i.e., one unit of fuel per unit of payload (assuming extinction of the return velocity by the first method; in the second method, the extinction of return velocity requires an altogether inconsequential quantity of charge). $n_m = 15$; $n_M = 45$; the nonreturnable transportation of loads from the base would require: to the moon $n = 4$, to Mars $n = 7$.

The transportation of loads from the earth to the base by purely rocket-powered means yields $n = 11$; by an artillery rocket device, $n = 7$; for a value of $n < 20$, in all probability, we could use just one cheap petroleum compound with greater economic advantage; for $n = 10-15$, it is no longer necessary to consume objects of the proportional passive load. Under such conditions, the payloads - high-quality materials and machines - with delivery to the moon and even Mars would be just slightly more costly than to earth. We have assumed throughout that landing on Mars will be executed without the aid of velocity extinction by resistance of the atmosphere on that planet. However, on Mars there is clearly a rather dense atmosphere, whose resistance could be utilized by the rocket for gliding descent, just as indicated for earth in section IX. The force of gravity on Mars' surface is only half as great, while the velocity w_M is less than half the value for earth; the operating power of the gliding rocket above Mars' atmosphere at the instant maximum value is reached will be, consequently, one sixth the value for gliding into the earth's atmosphere, so that danger of heating of the rocket surface will be nonexistent. The only remaining hazard stems from the structure of the surface on Mars, of which we know little, and from the presumed inhabitants thereon. In descending to Mars with velocity extinction by atmospheric resistance, the transportation of loads to Mars would cost about the same as to the moon, which is devoid of a dense atmosphere.

XIII. Experiments and Investigations

Considering the deficiencies in our knowledge in certain areas and lack of experience in the building of rockets for large velocities, before we can set about to build or design rockets for flights into interplanetary space, we need 596 to perform certain scientific and technological investigations; the main ones include:

I. Investigation of the functioning of the combustion chamber and exit tube of the rocket in media of various density and expansibility; determination of the best combustion chamber and exit tube constructions; determination of the most favorable shapes and length for the exit tube, techniques for injecting the

charge materials into the combustion chamber, the relations between exhaust mass dM/dt , dimensions of the combustion chamber, and the cross section of the exit tube.

Investigations of the operation of the rocket in an atmosphere of low expansibility (buoyancy) can be performed by leading the exit tube of a small model into a chamber from which the gases have been evacuated by a pump with a large volume capacity. For reducing the pressure without further increasing the dimensions of the evacuation pump, the chamber should contain a thick water spray, which will condense all the constituent parts of the exhaust except carbon dioxide, while the latter will be cooled, greatly enhancing the evacuation process. For even greater rarefaction, chemical compounds can be used which do not produce any carbon dioxide in the exhaust; however, with a pressure in the chamber of 0.01 atm, the functioning of the rocket will already be scarcely different from that in empty space.

II. Determination of the best constructions for all objects of the proportional passive load and techniques for their utilization as charge materials.

III. Investigation and development of production techniques for the charge materials until routine factory methods are available, for example, for the production of BH_3 , SiH_4 , O_3 , C_2H_2 , CH_4 .

IV. Determination of the best designs of compartments for personnel and all attendant instruments.

V. Determination of the best designs for automatic control and orientation (navigation) instruments.

VI. Investigations of the endurance of the human organism with respect to mechanical acceleration and life in air under reduced pressure with an elevated oxygen content.

VII. Determination of improved methods and types of astronomical instruments for rapid pilot orientation relative to the position of the rocket and its orbital data. Cautious training in such flight conditions in a simulated environment; the earth or other celestial body should be replaced by a large hemisphere, around which the trainee, housed in a chamber of the same dimensions and construction as the one intended for the rocket, will float in still water on a slowly moving stable raft.

VIII. Investigation of the atmosphere at altitudes to 100 km. This 597 investigation can be performed by means of projectiles or rocket-missiles fired from conventional large (naval) artillery pieces. On reaching the apex of its trajectory, the projectile should automatically eject as large a parachute as possible, made of lightweight white fabric with a weight hung on it. By observing the rate of descent of this parachute from earth, we gain some notion as to the density of the atmosphere at different heights. If we equip the parachute, instead of with a weight, with an instrument that automatically collects a sample of the air, we can formulate a precise (in every aspect) notion as to atmospheric data at different heights.

IX. Investigation of the heating of surfaces of moving bodies and the resistance of an appreciably dense atmosphere ($\rho = \rho_0$). This investigation can be carried out with projectiles for smaller velocities, while for large velocities it should be carried out with rocket-missiles fired from artillery guns at a small angle with respect to the horizon, calculated so as to land in the water where they could be recovered. The surface of these missiles ought to be coated with materials having different high-melting indices, insulating them from the metal body of the missile by a layer of porcelain. The maximum heating temperature can be estimated from the state of this surface of the missile after it has completed its flight.

X. Investigation of the heating of the surfaces of bodies at large velocities in a rarefied atmosphere (see section IX), as well as investigation of atmospheric resistance at large velocities and the endurance of various constructions of supporting (lifting) surfaces, conducted with small (up to 10 tons) rocket test models. The beginning of the trajectory of these test flights is calculated as the value of T_e for flight into interplanetary space, but with the attainment of heights from 60 to 100 km (depending on the meteorological data obtained in investigation VIII) the trajectory should automatically assume a horizontal direction, going into a gliding descent on its lifting surface when the rocket charge is completely spent.

During ascent, the angle of attack of the lifting surface, i.e., the angle between its minor axis and tailpiece, must be small, increasing gradually to the full value (about 40°) at the instant of burnout. To determine the maximum heating temperature of the rocket surface, the same procedure as in investigation IX can be used. In order to automate control of the test rockets, they should be equipped with the two gyroscopes described (in section X) for the actual rocket. These test flights should be executed with a gradually stepped-up maximum v_1 at the instant of charge burnout; the same rocket can be used for these. Just one petroleum compound with $n < 6$ needs to be used for the charge. After the maximum v attains a value of 7500 m/sec and the test model descends 598 safely into the lower layers of the atmosphere, it will be possible, according to tests on objects of the proportional passive load of appropriate dimensions, to go directly to flight with personnel into interplanetary space, flying around, for example, the unknown backside of the moon.

COMMENTARY

662

This work by Yu. V. Kondratyuk was first published as a separate book in Novosibirsk in 1929. Work was begun on it, however, much earlier. According to the author's attestation, this book, which represents the outgrowth of an earlier paper ("To Whomsoever Will Read in Order to Build," included in the present collection), was written in 1920, then revised and re-edited in 1923-24. In 1925, the manuscript was sent to V. P. Vetchinkin, who gave it the following review in April 1926:

Review by Mechanical Engineer V. P. Vetchinkin of Yu. Kondratyuk's article, "On Interplanetary Voyages"

In his preface, the author states that he was unable to become acquainted with the achievements of foreign scientists in this field, nor did he even have access to fundamental works of Tsiolkovskiy. Nevertheless, this did not prevent the author from obtaining all the results that had been obtained by researchers in interplanetary travel as a whole, a fact which is indeed to his credit.

At the same time, the totally unique language used by the author and his rather unusual expressions and notation, in terms of what scientists are accustomed to, gives every reason to believe that the author is self-educated, having studied at home the basics of mathematics, mechanics, physics, and chemistry.

Both of the above circumstances affirm the fact that mechanic Yu, Kondratyuk represents an enormous innate talent (of the same type as F. A. Semenov, K. E. Tsiolkovskiy, or A. G. Ufimtsev), having been cast off in some god-forsaken hole and having had no opportunity to utilize his capabilities in the right place.

We now turn to the work itself.

Section 1 presents the definitions pertinent to the rocket, to its load, and to the different segments of its trajectory.

Section 2 presents without proof the formula of K. E. Tsiolkovskiy relating the weight of the rocket and its fuel supply to the magnitude of the required velocity and reactive properties of the fuel.

In section 3, the problem of the possible exhaust velocity of the combustion products for various fuel agents is investigated in detail from the thermochemical point of view, insofar as this is possible with a total lack of experimental data and in light of Comrade Kondratyuk's lack of opportunity to perform the appropriate tests themselves.

Section 4 gives a formula indicating not only the advantage but the actual necessity of using several rockets in sequence (Obert proposes two rockets), since in the case of one rocket the fuel tanks must be so relatively lightweight that they could not possibly be built; here also he submits the proposal, similar to the proposal of F. A. Tsander (Moscow), that the tanks be burned up for fuel as they are spent, i.e., that the tanks be constructed from materials that can eventually be advantageously burned in the rocket. Obviously, the formula contained on page 15 (page 72 of the present collection) is in error and should be written in the form

$$\left[\frac{1}{1 - q(N_c - 1)} \right]^n$$

instead of the form given by the author:

$$\left[\frac{1 + q \left(1 + \frac{1}{N_c} \right)}{1 - q(N_c - 1)} \right]^n$$

In section 5, the very troublesome problems of the types of trajectories for rocket flight, the transition from one trajectory to another, the velocities required to do this, and the possible trajectories for escaping from earth and returning again are discussed. The very novel presentation and uncommon notation somewhat cloud the reading of this section; all of its results are correct, however; even in the problem of choosing a trajectory, Kondratyuk goes beyond the published literature, arriving at F. A. Tsander's notion of equipping the rocket with wings for flight in the atmosphere.

In section 6 is considered the problem of man's capability to withstand large accelerations in rocket flight. The author implies the proposition of Tsiolkovskiy that the pilot should desirably be situated in a reclining position and in a vessel containing water, but he adds to this the desirability of slowly rotating the man relative to his own lengthwise axis, so that the rush of blood and concomitant tendency of the blood to drain keep changing places in the human body, hence never have a chance to occur. The author bases his arguments on experiments with swings and giant strides (maypoles), indicating the possibility of imparting an acceleration of 3 g to a man without impairing his health. Stunt flying in modern acrobatics and military aviation have demonstrated the possibility of impart accelerations of up to 8 g; just how long 1664 accelerations can be endured over a protracted time period, which is only possible on rotating (centrifuge) machines, cannot be said, due to insufficient experimentation.

In section 7, the effects of the atmosphere on the rocket are discussed. Apart from his inadequate knowledge of the laws of aerodynamics (the use of the time-honored Lössl formula) and the latest research in the composition, temperature, pressure, and density of the atmosphere, the author demonstrates a tremendous capability of coping independently with all of the indicated difficulties and, proceeding from the most general physical considerations, he computes the density of the atmosphere, the energy of its resistance, and the conditions anent heating of the rocket during flight through the atmosphere at high velocities, proposing that the rocket be outfitted with wings and rudders - all with complete validity yet obviously with total ignorance of the present state of aviation.

In section 8, the problem of quenching the return velocity by resistance of the atmosphere is investigated in more detail, the author giving a completely correct trajectory of descent. Here, however, the author's utter lack of acquaintance with aviation structures, control techniques, etc., crop up. The author again treats the problem of heating of the rocket at an altitude of 4 to 6 km above the earth and arrives at rather reassuring results.

In section 9, the author talks about a base station, which would have to be a satellite of the moon, and about sending materials and supplies there by means of an artillery rocket device, carrying no passengers.

In section 10, he talks about control of the rocket and the instruments needed, wherein the problem is quite properly stated but without a constructive analysis in particular.

Section 11 gives the overall outlook and expectations, talking not only about flights around the earth and moon and to the moon, but also about flights to Mars. Despite the very favorable weight conditions for flight to Mars (almost the same as for flight to the moon), I would classify any such considerations as premature because of the long duration of the flight and the tremendous weight of the supplies (air, water, food, fuel) implied by this in order to sustain the rocket passengers during the time of the flight (which could not be less than six months).

Otherwise, we cannot accuse the author of delving into outlandish fantasy.

In section 12, the experiments and investigations that must be carried out before rocket flight into outer space are indicated. Once again, the considerations herein are sufficiently well thought out.

The work of Comrade Kondratyuk can be published as it now stands. Later on, his work could be unified with the work of other authors on the same problem (K. E. Tsiolkovskiy, F. A. Tsander, myself, and, probably, still others) so as to publish a good collective work; but such a book cannot be written quickly, and in order to preserve the priority for the USSR, printing of the finished work should not be postponed in face of the possible writing of newer and better material.

With this in mind, it is vitally essential to procure copies written by the author himself, since the copy sent to me for review does not stand up to criticism in the sense of revision, nor have illustrations been furnished, although reference is made to same in the text. Errors in writing the formulas are admitted, in that the dimensions of acceleration are written in the form $\text{cm} \cdot \text{S}^2$ instead of $\text{cm} \cdot \text{S}^{-2}$, and α is written as L, etc.

Besides publication of the work of Comrade Kondratyuk, he himself should (in the event that he would agree to do so) be sent to work in Moscow, in closer proximity to the scientific centers; here his talents could be utilized many times more fruitfully than on a grain elevator, here Kondratyuk could continue his self-education and work productively in his chosen field. Such enormous native talents are exceedingly rare, and to leave them unattended, from the point of view of the State, would be a manifestation of wastefulness on the highest scale.

Moscow, 12 April 1926

V. Vetchinkin

On the advice of V. P. Vetchinkin, Kondratyuk slightly modified his system ⁶⁶⁵ of notation and terminology, adding to the book a previously uncited derivation of the fundamental formula of rocket flight and a whole fourth chapter, "The Combustion Process, Structure of the Combustion Chamber and Exit Tube," which had not been a part of the earlier manuscript.

In spite of the favorable review given by Vetchinkin, The Glavnauka (Main Administration of Scientific Institutions) not only denied Kondratyuk a grant of funds for publication of this book, but administrative assistance as well, so that he was compelled to publish the book at his own expense with a local Novosibirsk printer. In 1947, in other words after the death of Kondratyuk, the work was reprinted by Oborongiz (State Publishing House of the Defense Industry) under the editorial supervision of P. I. Ivanov, at which time a number of editorial changes were incorporated therein.

In the present volume, the work is published in the same form as it was printed in 1929 during the author's lifetime. Only the list of symbols given at the end of the book have been omitted. Some of the comments made by the editor of the first printing, V. P. Vetchinkin, are included as footnotes.

The comments made in the 1947 printing by the editor, P. I. Ivanov, are given below:

Note 1, page 62. Actually, if $W_i/u \ll 1$, then $n_i = e^{W_i/u}$ can be written as the first two terms of a series, i.e.,

$$n_i = e^{\frac{W_i}{u}} = 1 + \frac{W_i}{u}.$$

Then, replacing the value of n_i by the two-term expansion in the expression $\mu = M_f(n_i - 1)$, we have

$$\mu = M_f \frac{W_i}{u}.$$

Note 2, page 63. Assuming u is constant.

Note 3, page 64. The problem, as stated by the author, appears reasonable at first glance. In actuality, however, the mixing of solid or liquid substances with the gaseous products of the exhaust results in a reduction of the exhaust velocity due to drag losses. Insofar as the process of heat exchange takes time, one could hardly expect, in the short period of time that the exhaust products are in the nozzle, that they could even compensate for the lost velocity. Other than that, a molten metal moving with the gas glow will have a higher velocity and will therefore cause mechanical destruction of the nozzle.

Note 4, page 66. The author interprets W_1 as twice the parabolic velocity W relative to the earth's surface, assuming that the velocity on the earth's surface is equal to zero and the rocket trajectory has the earth as its focus. In this case, $W = \sqrt{2gR}$, where R is the radius of the earth, g is the gravitational acceleration.

Substituting the values of R and g, we obtain

$$W = 11,185 \text{ m/sec.}$$

The author interprets W_2 as the difference between W_1 and the circular velocity $W_c \approx 7910 \text{ m/sec.}$

The coefficient in front of the number 11,185 is obtained from the following considerations. Since 666

$$W_1 = 2W, \text{ a } W_c = \sqrt{gR} = \frac{W}{\sqrt{2}},$$

it follows that

$$W_1 - W_c = 2W - \frac{W}{\sqrt{2}} = W \left(2 - \sqrt{\frac{1}{2}} \right) = \left(2 - \sqrt{\frac{1}{2}} \right) 11\,185 \text{ m/sec.}$$

Note 5, page 68. The author's idea is correct in principle, since the efficiency of an engine will in fact be increased when the pressure in the combustion chamber is elevated. However, considering account the weight of the combustion chamber at high pressures and the weight of the ancillary fuel injection equipments, it hardly makes sense to raise the pressure in the combustion chamber.

The author's reference to the hydrates of oxides is incorrect, as they cannot be formed in the combustion chamber. He overlooked beryllium, the most calorific metal.

Note 6, page 71. In fact, equation (6) can be written in the form

$$\mu = \frac{m}{\frac{1}{n-1} - q};$$

hence, if $q \ll \frac{1}{n-1}$, μ will be near $m(n-1)$. If q is increased the difference $\frac{1}{n-1} - q$ will tend to zero and $\mu \rightarrow \infty$ under the condition that the same m_1 functions throughout the entire flight.

Note 7, page 71. Here the author is speaking of μ being doubled by comparison with the μ for $m_1 = 0$.

Note 8, page 71. The condition $q \ll \frac{1}{5(n_1 - 1)}$ shows that in choosing q in accord with this condition we will have a value of u proportional to $\mu_0 = m(n-1)$ in the following sequence:

$$\mu = \frac{5}{4} \mu_0; \mu = \frac{6}{5} \mu_0; \mu = \frac{7}{6} \mu_0; \mu = \frac{K+1}{K} \mu_0$$

and the higher the value of K, the nearer μ will be to μ_0 .

Note 9, page 71. Since $n_i = M_{i_0} / M_{i_f}$, while M_{i_f} includes μ for the $(i + 1)$ th segment, it is not meaningless to speak of $n_i = 1$.

Note 10, page 72. In order to obtain the figures indicated by Kondratyuk, $q = 1/9$ for a two-unit system and $1/3.9$ for a three-unit system, it is necessary to recall that the author assigns a unit to each segment, while each segment has the same W_i , so that for a single-unit system we have W , for the two-unit system $\frac{1}{2}W = W_i$, and for the three-unit system $W_i = \frac{1}{3}W$. Since $n = e^{W/u}$, it follows that $n_i = e^{\frac{1}{2}W/u}$ for the two-unit and $n_i = e^{\frac{1}{3}W/u}$ for the three-unit system.

Consequently, we can represent n_i for the multiunit system in terms of n 667 one-unit systems as follows:

$$n_i = \sqrt[n]{e^{\frac{W}{u}}} = \sqrt[n]{n}.$$

For the three-unit system, the author gives a value of $1/3.9$, but it should be $1/3.65$.

Note 11, page 72. The fuel supply for $m_1 = 0$, according to equation (6) is

$$\mu = \frac{m(n-1)}{1-q(n-1)}.$$

The total weight, therefore, will be $u + m$, but since for $m_1 = 0$ we have $u = m(n-1)$, it follows that $u + m = mn$. Consequently, comparing the weight of the rocket for $m_1 \neq 0$ with $m_1 = 0$, we have

$$\mu + m + m_1 = \frac{m(n-1)}{1-q(n-1)} + m \neq m_1;$$

but

$$m_1 = q\mu, \text{ \& } \mu = \frac{m(n-1)}{1-q(n-1)},$$

so that we have

$$\frac{m(n-1)}{1-q(n-1)} + m + \frac{m(n-1)}{1-q(n-1)}$$

and, after some manipulation, we obtain

$$\frac{mn}{1-q(n-1)} \text{ or } mn \frac{1}{1-q(n-1)}$$

while, on the other hand, for a multiunit system $n = n_i^K$, and we can write therefore

$$mn_i \left[\frac{1}{1-q(n-1)} \right]^K$$

Note 12, page 74. The equation cited by the author, $w_e = v(\sqrt{2} - 1)$, can be derived under the condition that the parabolic velocity coincide with the direction of the circular velocity. v must be interpreted as $w_c = \sqrt{gR}$. Under these conditions, w_e will be equal to the velocity given by the author. In the event that the parabolic velocity does not coincide with the direction of the circular velocity, then

$$w_e = w_c \sqrt{3 - 2\sqrt{2} \cos \gamma},$$

where γ is the angle between the directions of the parabolic and circular velocities. The return velocity

$$w_r = \sqrt{w^2 - v^2}$$

transforms to $w_r = w \sqrt{1 - 1/2\bar{r}}$, if we let $v = \sqrt{gR}$ and $w = \sqrt{2gR}$.

Note 13, page 80. Equation (12) is obtained from equation (9) as follows: 668
Letting $j = j_0 + j_\rho$ and $g = g_0$, we write

$$\frac{dv}{dt} = j - g \text{ or } \frac{v dv}{dr} = j - g.$$

Since $v = dr/dt$, we have $v^2/2 = jdr - gdr$. Integrating with the initial conditions $v = 0$ and $r = R$, we have

$$\frac{v^2}{2} = jr - jR + gR - gr,$$

but, since

$$w^2 = 2gR,$$

replacing v by w , we obtain

$$jr - jR - gr = 0;$$

hence

$$r = R \frac{j}{j-g}.$$

But, since

$$W_i = \sqrt{2gr},$$

replacing r by $R \frac{j}{j-g}$ here, we have

$$W_i = \sqrt{2gR} \sqrt{\frac{j}{j-g}} = w \sqrt{\frac{j}{j-g}};$$

We now turn to equation (9) and determine L_g . Inasmuch as j_0 is imparted to the rocket in the immediate vicinity of earth, $g = g_0$, v_2 is the velocity of the rocket at infinity, and, consequently, $v_2 = 0$; v_1 is the velocity on the earth and is also equal to zero, $\bar{r}_2 = \infty$, $\bar{r}_1 = 1$, since $r_1 = R$ by virtue of the fact that velocity is imparted near the earth. From these assumptions, therefore, we have

$$L_g = W_i - w. \text{ But } W_i = w \sqrt{\frac{j}{j-g}},$$

hence

$$W_i - w = w \left(\sqrt{\frac{j}{j-g}} - 1 \right),$$

or, introducing the notation $j/g = \bar{j}$, we have

$$L_g = \left(\sqrt{\frac{\bar{j}}{\bar{j}-1}} - 1 \right) w,$$

i.e., we have derived equation (12).

Series expansion of the expression under the radical with the condition $\bar{j} \gg 1$ leads to an expression of the following form: $L_g = \frac{1}{2\bar{j} - 1}$, rather than 669 the relation cited by Kondratyuk, i.e.,

$$L_g = w \frac{1}{2(\bar{j} - 1)}$$

Note 14, page 85. Recent investigations have shown that a human being, lying on his back, can tolerate accelerations considerably higher than stated by the author.

Note 15, page 112. The exhaust velocity $u = 4700$ m/sec is much too high in contrast with what is actually feasible.

Note 16, page 113. Here, n_E , n_m , n_M are the values of n for earth, the moon, and Mars, respectively.

THE WORKS OF THE RUSSIAN SCIENTIST-PIONEERS OF
ROCKET TECHNOLOGY (HISTORICAL OUTLINE)

N 66-12167
/601

V. N. Sokol'skiy

The development of rocket technology in our country has a history of more than one century. Its origins go deep into the past. Already in the seventeenth and eighteenth centuries, the Russian master pyrotechnicians were renowned for their knowledge in the preparation of fireworks, leaving a tremendous impression on specialists in the field. In the nineteenth century, military rockets were made and used in Russia, and by the middle of the nineteenth century the research genius of our inventors and designers was beginning to be directed toward the possible utilization of the reactive principle in solving the problem of flight.

In 1849, in Georgia, which is in the southern part of Russia, the military engineer I. I. Treteskiy (1821-1895) developed the concepts for three lighter-than-aircraft. These were supposed to be set in motion by means of a gas or steam reactive jet (ref. 1). He proposed the use of steam or alcohol vapors, the gases evolved by gunpowder, or compressed air as the propelling force. Accordingly, Treteskiy categorized his flying machines into steam, gas, and air machines. Treteskiy's concepts suffered from serious defects, could not be realized in practice, and were thus rejected by the Committee on Military Science (see ref. 2). However, Treteskiy's paper "Methods for the Control of Aerostats (O sposobakh upravlyat' aerostatami)," grounded in mathematical calculations and supplied with numerous diagrams and plans, undoubtedly deserves recognition as the first scientific effort in Russia to solve the problem of utilizing the reaction propulsion principle for flight.

The flying machines proposed in the 1860's by N. M. Sokovnin (1811-1894) /602 and Artillery Captain N. A. Teleshev (1828-1895) were based on the same principle.

Asserting in a paper published in 1866 his lasting conviction that "a flying ship must fly by a method similar to that used in the flight of a rocket" (ref. 3), Sokovnin suggested the concept of a reaction aerostat, whose movement in a horizontal direction would be achieved by the reaction of compressed air which would flow out of tubes located on board the air ship.

A concept for a reactive airplane, for which a patent was issued to Teleshev in 1867 in France, is of great interest.¹ Judging from the description in the patent record, Teleshev's airplane was a reactive flying machine, heavier than air, which was set in motion by the release of gases formed during an explosion of a mixture in a hollow cylinder, which served as the combustion chamber. Liquid fuel (actually Teleshev did not specify what kind) was supposed to be used as the fuel, atmospheric oxygen as the oxidant.

¹ Teleshev's patent is now preserved in the National Museum of Aeronautics in Paris. The information given here concerning it is based on the materials published in the Soviet periodicals.

One of the most prominent representations of the Russian artillery school in the middle of the nineteenth century, K. I. Konstantinov (1818-1871), was also concerned with the possibility of applying the principle of reaction propulsion to the problems of flight. However, on the basis of experiments conducted with the aid of a rocket ballistic pendulum, he decided that the use of rockets for the movement of aerostats was impossible.

In 1870, Treteskiy again submitted a revised project on the reactive aerostat, suggesting this time only the use of reactive gases (formed during the combustion of gunpowders). This project was examined by a "Special Committee" appointed expressly for this purpose; however, it was again rejected.²

Among the authors of projects dealing with reactive flying machines, a special place is accorded the revolutionary member of the "People's Freedom Movement" Nikolay Ivanovich Kibal'chich (1853-1881). Two circumstances separate him from the others who thought about the application of the reaction principle to solve the problem of flight.

The first is his outstandingly eminent brilliant biography, the biography of a scientist-revolutionary, who devoted all his strength and knowledge to the struggle for the liberation of the people and, until the last days of his life, was constantly concerned with the welfare of mankind.

The second is something absolutely new, which was not encountered before 1603 in other concepts, the rocket-dynamic principle for creating lifting power, excluding air as a supporting medium.

Before Kibal'chich, numerous authors of projects on reactive flying machines in Russia, as well as in other countries, suggested the use of the reaction propulsion principle only to realize the movement of an aerostat or an airplane in the horizontal direction; i.e., to propel the flying machine.

The lifting power in all the concepts, without exception, had to be formed either due to the gas being lighter than air (aerostatic principle) or as the result of airfoils (wings) due to an air current (aerodynamic principle). In other words, in all the projects mentioned above, the machines needed the atmosphere as a supporting medium and were designed for flights within its lower layers.

Kibal'chich's flying machine was based on a completely different principle. The atmosphere was not only unnecessary for its flight, but it was even harmful since it created additional resistance.

Without examining in detail, the construction of the "aeronautical machine" suggested by him, since it is clearly stated in Kibal'chich's description (see the article by Kibal'chich in this collection), we should note that

²The concept outlined by Treteskiy and the decision of the "Special Committee" have not been found yet. Only Treteskiy's objections to the remarks of the Committee are preserved. See the Central State Archives on Military History (TsGVIA), folio 802, catalog 3, document 79, sheets 336-338.

the lifting power was formed with the aid of a gunpowder rocket engine, whose operation did not really depend on the composition of the surrounding medium.

It is not difficult to see that Kibal'chich's flying machine was also suitable in principle for flights in vacuous airless space. The author of the project did not speak about this himself. He posed for himself a more modest task: the creation of a flying machine capable of moving through air in a given direction. However, the "aeronautical machine" suggested by him was in essence the first rocket flying machine that did not need air as a supporting medium.

Evaluating Kibal'chich's project, from our present point of view, it is possible to find in it, undoubtedly, many shortcomings and even essentially incorrect solutions. Moreover, a detailed analysis of the project shows that, in the state Kibal'chich described it, the flying machine could not be realized.

However, we cannot but admire the courage of a man who worked out his astonishing project at the time in a death chamber a few days before his execution. One must give credit to the talented scientist-inventor who envisaged such technological questions as the use of multi-compartment machines, programmed combustion systems; armor-encasement of gunpowder securing the stability of flight, etc. /604

Because of this, we are justified in regarding Kibal'chich as one of the pioneers of rocket technology and in placing him among those who, through their efforts, have paved the way for the enormous achievements accomplished in our own era in the conquest of outer space.

Almost contemporarily with Kibal'chich, but completely independently of him and, most likely, not even aware of his project, another Russian scientist-inventor, Sergey Sergeevich Nezhdanovskiy (1850-1940),³ began to work with the problem of reactive flight.

Nezhdanovskiy began to study the questions of aeronautics at the end of the 1870's, and in July 1880 he arrived for the first time at the possibility of designing a reactive flying machine, which is evident from his notes entered at this time in his log: "The flying machine is possible with the use of explosives, the products of their combustion are ejected through a device like an injector" (ref. 5).

At the end of 1880, Nezhdanovskiy made several calculations relating to the rocket flying machine, propelled by the reaction of gunpowder gases. After having calculated for two types of engines (with the pressure of the gunpowder gasses equal to 150 and 200 atm.), Nezhdanovskiy arrived at the following conclusion: "I think that it is possible, and we should design a flying machine."

³ S. S. Nezhdanovskiy's estimates and calculations relating to reactive flying machines have survived in his logs, which are presently kept at the N. E. Zhukovskiy Memorial Museum in Moscow.

It can carry man through air for at least 5 minutes. A funnel, in letting the air escape at the most advantageous velocity, will economize the intake of fuel and increase the duration and length of flight" (ref. 6).

In 1882, Nezhdanovskiy returned to the idea of designing a reactive flying machine and examined various types of engines set in motion by the reaction of carbon dioxide gas, water vapor, and compressed air. In particular, he expressed the conceptual notion of designing a reactive engine "according to the principle of the rifle or double- or triple-barreled mitrailleuse (a 19th century machine gun) again in order to be able to control the power and time of flight" (ref. 7).

In the same year, 1882, Nezhdanovskiy expressed an idea concerning the possibility of designing two types of reactive heavier-than-aircraft, with wings and without them. In addition, he pointed out the possibility of using one of the suggested reactive engines, which worked by reaction of compressed air for the horizontal movement of lighter-than-air flying machines (a cigar-shaped air balloon). /605

At the same time, Nezhdanovskiy attempted to estimate the work necessary for realizing reactive flying. One of the first problems he posed was determining the work necessary for compensating the forces of gravity of the flying machine. On the basis of his calculations, Nezhdanovskiy arrived at the conclusion that the forces necessary to support a body are directly proportional to the velocity of air that flows out of the engine and inversely proportional to the square root of the wings' surface as the square root of the cross section of the opening from which the air flows out that governs the reaction (ref. 8).

Differing from the majority of the inventors who worked on the reaction principle earlier, Nezhdanovskiy hardly concerned himself with developing the construction of flying machines, and devoted most of his attention to the problem of designing an engine and finding the best fuel for it.

"It seems to me," he wrote in one of his logs, "that it is enough to plan and draft a machine-engine satisfying the conditions that I have set down; I will leave the construction of the machine to other engineers" (ref. 9).

Actually, in Nezhdanovskiy's notebooks, it is possible to find many original ideas, which have very real significance and are undoubtedly of interest.

Already in 1882-1884, he suggested the use of an adapter through which the working body (steam or gas) would pass and entrain with it a large mass of atmospheric air, which, according to Nezhdanovskiy, would bring an increase in reactive efficiency.⁴

⁴ We note that this suggestion was first published by F. Geshvend, who in 1887 in a paper "The General Design of an Aeronautical Steamship (Steam Driven Airplane)," provided a description of a reactive engine with similar adapters. Later, these adapters appeared in many concepts and were long known in the scientific-technical literature as "Melo Adapters."

"It is possible, according to Patent No. 134 (1880),⁵ to prepare an explosive 607 mixture from two liquids that were mixed just before an explosion (these are hyponitrous acid NO_2 and kerosene, two parts of the former and one part of the latter; another such combination is hyponitrous acid and picric acid). This method can be used in designing a flying rocket with a large reserve of explosives, which are produced gradually according to the rate of combustion.. One liquid (a) is pumped through a tube and the other (b) through a second tube. They are then mixed, detonating to produce a flow which carries air to the funnel-shaped opening, A, of the reaction" (ref. 11).

It is not difficult to see that Nezhdanovskiy expressed the principle of liquid rocket engines. We note, however, that he proceeded from commercial operational considerations. Nezhdanovskiy did not pay any attention to such important advantages of liquid rocket engines as independence of their performance from the ambient conditions and their significantly larger energy-storage capacity in comparison with other reactive engines known at the time.

In the middle of the 1890's, Nezhdanovskiy once again returned to the problem of reactive flight and suggested the construction of reactive helicopters of one- and two-blade design. "A helicopter," he wrote in 1885, "can be made with turbines, each blade operating simultaneously as a Segner's wheel, which is made to operate off of the combustion products (ref. 12).

According to Nezhdanovskiy's concept, at the main-blade tips "reactive burners" should be installed which are essentially the prototype of the present-day ram-jet engine.

One of the things that is difficult to explain is why Nezhdanovskiy did not publish at an opportune time the results of his research in the field of reactive engines.

The history of science is rife with examples of numerous outstanding inventions and discoveries, which were too advanced for their day, and for a long time remained unknown, failing to become one of mankind's achievements until these ideas had ceased to be novel and had been developed to a great extent by subsequent generations.

This happened to the notes of Leonardo da Vinci on helicopters, and to 608 some of the works of Cayley on aerodynamics.

⁵Nezhdanovskiy's manuscript, clearly contains a slip of the pen: Patent No. 134 of 1880 was issued to E. Bert and F. Borel' for developing a new type of telegraph cable. Evidently, he had in mind Patent No. 154 of 1880, which was issued to A. Gel'gof, G. Gryuzon, and I. A. Gal'bmayer for the preparation and application of a new type of explosive. As stated in the patent, the above mentioned explosive is obtained by treating mono-, di-, and trinitro derivatives of naphthalene, phenol, toluene, benzene, and xylene with nitric acid (see ref. 10).

Among the same group of researches we should include notes relating to reactive engines. They were rather advanced for their time and did not become known until this publication was of no more than historical interest⁶ and, therefore, could not noticeably influence the development of rocket technology. The list of people who were working in our country in the last quarter of the nineteenth century on the problem of reactive flight is not exhausted by the names of Kibal'chich and Nezhdanovskiy. We should also mention F. Geshvend and P. N. Lebedev, S. M. Nemirovskiy and V. D. Spitsyn, A. P. Fedorov and A. V. Eval'd.

During these years in Russia, more than ten concepts for reactive flying machines were proposed. Inventors were attracted by the apparent simplicity of solving the problem of flight with the aid of engines based on the reaction principle. With this, however, the authors of the majority of the concepts limited themselves to giving just a diagram, or stating the principle involved in the performance of the engines without giving either its construction technique or accurate calculations of the amount of energy necessary for carrying out reactive flight, which provides us no basis for regarding the proposals suggested by them as engineering concepts. It is more likely that they were invention claims. Not one of the proposed reaction flying machines was ever built.

The projects of Geshvend and Fedorov present the greatest interest from the works of this period.

In 1887 Geshvend presented a concept for a reactive airplane (steam-powered plane) which was supposed to be motivated by the reaction of steam (ref. 13). Geshvend's flying machine was a biplane with a rather complex fuselage configuration. The area of the lifting surfaces was 30 m², the length of the machine was 9m, the height was 3m, the width was a little over 1m, the span of the wings reached 3m.

The steam engine was located in the front part of the fuselage, from whose boiler the steam entered the steam-jet apparatus under heavy pressure. We should note that Geshvend, like Nezhdanovskiy, proposed the use of several nozzles 1609 through which the steam would take with it a large mass of atmosphere air and would increase the reactive efficiency by this means.

In the same year, 1887, Geshvend made important revisions in his project. He rejected the use of wings as supporting surfaces and proposed substituting for them an additional steam-jet apparatus which would be vertically positioned (ref. 14). Small wings (decreased fivefold in size in comparison with the first project) were maintained only as stabilizing surfaces in order to prevent rotation of the flying machine around a longitudinal axis.

⁶The first accounts of S. S. Nezhdanovskiy's researches in the field of reactive motion were made by co-worker A. I. Yakovlev of the Moscow Aviation Institute (MAI), at a conference sponsored by the Department of Aviation Engineering History of MAI (9 January 1957) and at a meeting of the Aviation Section of the Soviet National Union of National Science and Technology Historians (2 March 1959).

Geshvend pointed out that his steam-plane could not only move through air in various directions but could also be suspended motionlessly in one place. He wrote: "By using one vertical apparatus, it would be possible to stay in the air in one place, motionless for more than an hour (because the consumption of steam and water is less than an hour's supply of water). In the face of wind, it is possible to stay in one place by using the horizontal apparatus, facing the wind, thus the consumption of steam will increase insignificantly, even with a brisk wind" (ref. 14, p.2).

Geshvend's second variant of the project differed conceptually from the original one, because, like Kil'bachich's project it was not based on an aerodynamic principle but on a principle of rocket dynamics.

In 1888 Geshvend's project (the first variant) was examined at a meeting of the Committee on Military Science but was rejected. We should note that the project was not really reviewed. The main reason for its rejection was the fact that it was not carried out in practice and particularly because it was based on "the airplane principle", which, in the opinion of the Committee, rendered it unfavorable as a foregone conclusion (ref. 15).

The committee did not pay any attention to the fact that the second variant of Geshvend's project was not based on "the airplane principle" but on a rocket-dynamic principle.

A. P. Fedorov's project, given in the work "A New Principle of Aeronautics Excluding the Atmosphere as a Supportive Medium," published in St. Petersburg in 1896, is also of great interest.

Fedorov, noting that all preceding concepts for flying machines, as well as theoretical works in the field of aeronautics, were based on the use of atmosphere as a supporting medium,⁷ showed that his project "is contrary to 610 the basic prevailing attitude toward the solution of the problem and attempts to pose the latter by a new approach" (ref. 16, p. 3).

According to Fedorov's concept, the flying machine was set in motion with the aid of a system of tubes whose cross section is shown in figure 2.

As the inventor stated, the compressed gas enters through a branch pipe, PP, into the annular cavity, fills it, then passes through the opening, ah, into the cylindrical channel, abgh, and through the opening bg, and exits to the outside. With this, the gas pressure on a part of the area is equal to the projection of bg onto de, is not equalized by anything.

"Therefore," wrote Fedorov, "our pipe, just as a rocket in flight or a rifle in firing, will tend to move along its axis from b to a. In other words, a force will be applied to the tube, whose direction, given any position of the

⁷Evidently, Fedorov did not know about the flying machine concepts of Kibal'chich.

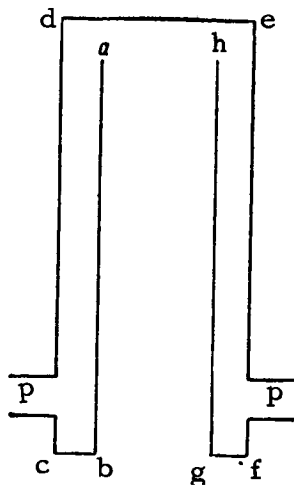

Figure 2

tube, will coincide with the longitudinal axis of the latter and will proceed from the open to the closed end" (ref. 16, p. 13).

He further stated that: "...If we make a system of such tubes in which 1) some of them stand vertically, with their outlet openings, bg, down: 2) others lie horizontally along the longitudinal axis of the system; 3) others form spirals coiling around the vertical axis of the system, then the first group will give us the lifting force, the second will give translational movement, and the third will give rotation around a vertical axis, in other words, will substitute for the rudder. This system will therefore possess all the requirements for free flight" (ref. 16, pp. 13-14).

The significance of A. P. Fedorov's work is not exhausted by the ideas contained in it. It played a major role in the history of rocket technology in our country, having served as the starting point of K. E. Tsiolkovskiy's arguments concerning the theoretical basis of rocket flight. Here is what the scientist himself wrote: "In 1896 I ordered A. P. Fedorov's book *The New Principle of Aeronautics* ... It seemed unclear to me (because no calculations were given). And in such cases I have taken it upon myself to carry out the calculations personally, from scratch. This is the beginning of my theoretical research on the possibility of using reactive devices for space travel" (ref. 17). /611

Tsiolkovskiy had thought even earlier about the feasibility of interplanetary voyages. The first time this thought occurred to him was in 1872, when he was only 16 years old. He suggested even then the use of centrifugal forces for achieving cosmic velocities.

Ten years later, Tsiolkovskiy for the first time indicated the possible utilization of the reaction propulsion principle for flights through space. In 1883, in his manuscript, "*Free Space (Svobodnoye prostranstvo)*", he came to the

conclusion that the only possible method of travel in space, where neither the forces of gravity nor the resistive forces of a medium are operative, is a method based on the reaction elicited by particles of matter being ejected from the particular body.

But the beginning of his serious research in this field dates to 1896. At this time, proceeding in his customary manner and striving to simplify the conditions of the problem as much as possible, Tsiolkovskiy first investigated the flight of a rocket through a medium where the forces of gravity and resistance of the medium are, for all practical purposes, nonexistent.

It is important to mention that rockets were known long before Tsiolkovskiy. They were used for fireworks and for signaling purposes, for illuminating an area and as military means. Many scientists and inventors worked on perfecting rockets, but none of them suggested that they might be used for interplanetary communication. On the other hand, even before Tsiolkovskiy, many inventors thought about the problem of flight into space. They proposed such devices as a gigantic sling, a circular railway, ultralong-range artillery, and others, but not one of the authors of the numerous projects suggested the use of rocket-type flying machines for this purpose.⁸

Tsiolkovskiy's merit consists in the fact that he brought together these two technological trends, establishing on rigorous scientific grounds the conceptual application of the reactive principle for flights in outer space and formulating the theory of rocket motion. This problem was complicated by the fact that a rocket, being a body of changing mass, could not be subjected to calculations according to the formulas of classical mechanics. It was necessary to construct a new branch of theoretical mechanics - the mechanics of bodies of variable mass. /612

A major contribution was made by I. V. Meshcherskiy (1859-1935) in the solving of this problem. In 1897-1904 he published his main works, devoted to problems in the mechanics of bodies of variable mass. In his masters' thesis (ref. 18) Meshcherskiy showed that "in analyzing the movement of a body of variable mass, our problem reduces to the motion of a material point whose mass changes with the passage of time" (ref. 18, p. 50). For the first time

⁸It should be noted that early allusions to the use of rockets for flights to the moon are encountered in two science-fiction works: Cyrano de Bergerac's "L'Histoire comique des etats de la lune (A Comic History of the Nations of the Moon)" (1647-1650) and Jules Verne's "Around the Moon" (1870). However, Cyrano de Bergerac's proposal was a complete fantasy, and in Jules Verne rockets are used only to change the velocity and direction of a cannon ball in flight.

in the scientific literature, he derived the fundamental equation of a moving point of variable mass in the following form:

$$m \frac{dv}{dt} = F + \frac{dm}{dt} (u - v),$$

where

m is the mass of the fundamental point,

v its velocity,

dv is the velocity's increment of the point,

dm is the ejected particle mass,

u is its absolute velocity,

and f is the resultant of all external forces.

In the same work, Meshcherskiy, as an example, investigated the vertical motion of rockets. He wrote: "At the time the rocket is ascending, its mass decreases (underlined by Meshcherskiy) as a consequence of combustion of the substance with which it is charged. The forces acting on the rocket are: force of gravity, resistance of the air (drag force), force due to pressure of the gases evolved in combustion of the motivating compound, and an additional force, if we take into consideration that the burning particles are ejected with some relative speed" (ref. 18, p. 80). Proceeding from this and directing the axis ox vertically upward, Meshcherskiy obtained the following equation of motion for the rocket:

$$m \frac{d^2x}{dt^2} = -mg + p - \frac{dm}{dt} w - R(\dot{x}),$$

where

m is the mass of the rocket,

g is the gravitational acceleration,

p is the gas pressure,

w is the value of the relative velocity, possessed by the burning particles at the instant of exhaust,

x is the velocity of the rocket,

R(x) is the air resistance.

Due to the fact that by the end of the nineteenth century, rockets had no 613 practical application (as military weapons, they had ceased to be of significance and were removed from the arsenals; but in the application of rockets for solving problems in aviation and aeronautics, designers were taking their first tentative steps, although still unsuccessfully at that time), Meshcherskiy limited himself to formulating the problem of the vertical motion of the rocket in a very general way.

In 1904, Meshcherskiy published a work devoted to the dynamics of a variable-mass point in the case of simultaneous attachment and detachment of particles (ref. 19), a case which occurs, for example, in the operation of a ram-jet engine.

The works of Meshcherskiy on the mechanics of bodies of variable mass are of significance even today and give him the right to be regarded as one of the founders of this new branch of theoretical mechanics.

K. E. Tsiolkovskiy worked out, in more detail, the theory of rocket motion, taking the variable mass into account. Familiarization with his working materials, which are preserved in the Archives of the Academy of Science of the USSR, shows that in 1897 he had formulated his well-known formula, establishing the analytical relationship between the rocket velocity at any instant, the exhaust velocity of gas particles from the reaction engine, the mass of the rocket, and the mass of the consumed charge.

To generate this formula, Tsiolkovskiy proceeded from the hypothesis of a constant relative velocity of efflux of gas particles. This hypothesis of Tsiolkovskiy is (widely) used in the rocket dynamics of today.

According to Tsiolkovskiy's formula, the velocity of the rocket's flights (ignoring the forces of gravity and air resistance) is equal to:

$$V = V_1 \ln \left(\frac{M_1 + M_2}{M_1 + M} \right),$$

where

V is the velocity of the rocket at any instant,

V_1 is the relative velocity of efflux of gas particles,

M_1 is the mass of the rocket minus the charge,

M_2 is the total mass of the charge at the onset of motion,

M is the changing mass of the still undetonated charge at a given instant.

The maximum velocity will occur when $M = 0$, i.e.,

$$V_{\max} = V_1 \ln \left(1 + \frac{M_2}{M_1} \right)$$

It is not difficult to see that the rocket velocity in vacuum is theoretically, unlimited and depends only on the velocity of the outflow of gas particles and on the relationship of the explosive mass to the mass of the rocket. /614

Tsiolkovskiy's derivation was of great significance to the further development of rocket technology, because it attested to the possibility of achieving cosmic velocities and showed in which directions theoretical research had to be developed, an accomplishment that would help in solving his problem. According

to Tsiolkovskiy's formula, in order to increase the velocity of the rocket, it would be necessary to strive for an increase in the efflux velocity of the gas particles and on an increase in the relative (rather than the absolute) fuel reserve.

This formula gave an ideal velocity of a rocket without calculating the losses caused by the forces of gravity and the resistance of the medium. Later, Tsiolkovskiy complicated the problem; he introduced into his calculation the earth's gravitation and air resistance, performing calculations for cases approximating actual conditions.

By introducing into his calculation the force of gravity, Tsiolkovskiy obtained:

$$V_{\max} = V_1 \left(\frac{p-g}{p} \right) \ln \left(1 + \frac{M_2}{M_1} \right),$$

where

p is the absolute acceleration of the rocket,

g is the earth's gravitational acceleration.

In 1903 Tsiolkovskiy published his classic work, "The Investigation of Cosmic Space by Reactive Devices," in which, for the first time, the possibility of carrying out cosmic flights with the aid of rockets was scientifically substantiated and the principal working formulas for its flight were given. In the same work, great attention was paid to the question of finding the best fuel for a space rocket. Until the end of the nineteenth century, only reactive engines using solid fuel - gunpowder rockets - were considered. However, Tsiolkovskiy showed that for long-range rockets the most effective engine is the liquid-fuel engine; he gave the principal diagram for such an engine.

It is difficult to overestimate the importance of Tsiolkovskiy's work "An Investigation of Cosmic Space by Reactive Devices." However, in the first decade of the twentieth century this work was unnoticed in Russia, as well as abroad. It was published for the second time (in a significantly expanded form) in 1911-12 in the journal Vestnik Vozdukhoplavaniya (Aeronautics Bulletin). In the work of 1911-12, Tsiolkovskiy investigated the resistance of the atmosphere in detail and came to the conclusion that the work necessary for overcoming atmospheric resistance is only an insignificant part of the work necessary for overcoming the forces of gravity.

It was also here that Tsiolkovskiy expressed the notion of utilizing energy from atomic fission for space flights. "It is thought that radium, which constantly decomposes into a more elementary material," he wrote in 1912 615 in the Journal Vestnik Vozdukhoplavaniya, "emanates particles of different various masses, which move with an astounding and inconceivable velocity, not far from the speed of light. Therefore, if it would be possible to sufficiently accelerate the decomposition of radium or of other radioactive bodies, which probably includes all bodies, its use could, all other conditions being equal, impart such velocities to a reactive device that reaching the nearest

neighboring sun (star) would be shortened to 10-40 years" (ref. 20, pp. 7-8).

At the same time, he advanced the basic ion engine concept, that "perhaps with the aid of electricity it will be possible, in time, to impart an enormous velocity to the particles ejected from a reactive device" (ref. 20, p. 8).

In the same work, Tsiolkovskiy expresses his views on the outlook for the growth of mankind, man's reaching out into boundless space, his taking possession of enormous energy reserves of the universe. "The motion around Earth," he stated, "of several vehicles with all the necessary equipment for the existence of being capable of reason could serve as a base for the further development of mankind. Settling around earth in many rings similar to the rings of Saturn ... the people increase 100- to 1000-fold the reserve of the sun's energy sent to the Earth's surface. But even this may not satisfy man and from the conquered base he may reach out to embrace the remaining solar energy, which is two billion times what the Earth receives" (ref. 21).

"The better part of mankind," he continued, "most likely will never perish, but will move from sun to sun as they burn out. After many decillions of years, we will perhaps live by a sun which has not yet ignited but exists, only in an embryonic state, predestined by eternity for higher aims" (ref. 20, pp. 10-11).

We should mention that Tsiolkovskiy did not limit the problems confronting mankind to the conquest of planets and other heavenly bodies. Moreover, he stated that there was no need to go to heavy planets, except for study. The way to master space would be to create artificial settlements in interplanetary space and subsequently in interstellar space.

Tsiolkovskiy believed without reservation in the possibilities of the human mind and considered that there is no limits to the improvement of the lives of the people. "If even now we have reason to believe to some extent in the immortality of mankind," he wrote, opposing the forewarnings of some /616 scientists on the inevitable destruction of every living thing on earth as a consequence of its cooling and due to extinction of the sun, "then what will happen in several thousand years, when our knowledge and reason have increased?"

"So there is no end to life, reason, and the perfection of mankind. Its progress is eternal. Go forward bravely, you great and small laborers of the earth species and know that not one iota of your labor will perish without a trace, but will bear you great fruit in eternity" (ref. 20, p. 11).

In 1914, Tsiolkovskiy published, in a separate brochure, a supplement to the works of 1903 and 1911-12, in which he formulated his theories concerning reactive propulsion. Here also, he pointed to the possibility of using ozone as an oxidant.

Tsiolkovskiy's ideas in the field of interplanetary communication were far ahead of their time. At the beginning of the twentieth century, there were no technical or economic criteria for the creation of long-range rockets. In order to realize the concepts of the scientist, it was necessary first to solve numerous complex problems from various fields of science and technology, an

objective requiring a great deal of long-term theoretical and experimental work. Tsiolkovskiy's research in the field of rockets was further complicated by the fact that in pre-revolutionary Russia he received neither moral nor material support. He encountered attitudes of indifference and disbelief, many considered him a baseless dreamer and treated the self-taught scientist, who had no diploma, with skepticism.

This situation was altered considerably after the Great October Socialist Revolution. Tsiolkovskiy's ideas relating to the conquest of space began to receive more widespread acceptance and recognition in the USSR and are reflected in the pages of the periodical literature. In 1924, the first Society for the Study of Interplanetary Communication was organized in our country.

Continuing his research in the field of reactive propulsion, in 1921, Tsiolkovskiy composed the draft of an article entitled "The Rocket", in which he planned to examine several questions of reactive flights in vacuum and within the boundaries of the atmosphere. To this same period belong his manuscripts and published works: "The Cosmic Rocket" (1923), "Reactive Device" (1924), "A Rocket into Cosmic Space" (1924), "Space Ships" (1924), "An Investigation of Cosmic Space by Reactive Devices" (1926), and others.

In these works, Tsiolkovskiy continued to develop and deepen his idea of 617 the conquest of space with the aid of reactive devices. The last two works, in which Tsiolkovskiy included several new proposals not encountered in his previous works, are of special interest.

In the last years of his life, Tsiolkovskiy focused most attention in his research on interplanetary communication, on two problems: the achievement of velocities of cosmic magnitude and finding the best rocket fuel.

Working to solve the first of these problems, Tsiolkovskiy, already in 1926, came to the conclusion that a rocket would be able to achieve cosmic velocities only if it could acquire a comparatively high starting velocity without depleting its own reserve of fuel. Having analyzed the possible methods of imparting this initial velocity to the rocket, Tsiolkovskiy came to the conclusion that "the simplest and least expensive means in this case is the rocket, or reactive approach." Proceeding on this basis, he proposed to achieve cosmic velocities by using a two-stage rocket, the first stage of which in Tsiolkovskiy's terminology, would be an "earth rocket," which would have to travel on the earth and in the dense layers of the atmosphere.

Tsiolkovskiy also calculated the reserve of fuel, the mass of the structure, the velocity, and other parameters for each stage.

The later development of the theory of multi-stage rockets was given in Tsiolkovskiy's book "Cosmic Rocket Trains" (1929) and in one chapter of his manuscript "Design Principles of Gas Machines, Motors, and Flying Machines" (ref. 22), which was not published during the scientists' lifetime.

We should note that the idea of multi-stage rockets is several centuries old. They are first mentioned in the sixteenth and seventeenth centuries.

However, in the present case also it is to Tsiolkovskiy's credit that he did not just limit himself to stating the propulsion principle of multi-stage rockets, but gave their detailed mathematical theory and in a strict scientific manner demonstrated the feasibility of cosmic velocities with the aid of rocket engines driven by chemical fuel.

Tsiolkovskiy proposed two methods for attaining cosmic velocities: by means of a train of rockets and with the aid of a rocket squadron. Both methods had a great deal in common and consisted of launching several rockets, of which only one reached the final goal. The other rockets played the part of boosters and, after expending their fuel, returned to earth.

However, in the first method (the space rocket train) the rockets were linked one after the other with only the lead rocket functioning. After the fuel of the lead rocket was used up, it separated from the rocket train, after which the second rocket began to perform, having now become the lead rocket, etc. /618

In the second method (rocket tandem), the rockets were linked parallel to one another and performed all together, but used up only half of the fuel. After this, the fuel of one part of the rockets emptied out into the half-full tanks of the other rockets, and they continued on their route with full reserves of fuel. The empty rockets separated from the squadron and returned to earth. This process continued until only one rocket from the squadron remained.

In 1932, Tsiolkovskiy wrote his work entitled "Reaching the Stratosphere." In it, the scientist, as though summing up his many-year research in the field of rocket power engineering, formulated the requisites for explosives designed to be used in reactive engines. He wrote: "The elements of explosives for a reactive engine must possess the following characteristics:

1. For each unit of their mass in combustion, they must perform at their maximum capacity.
2. When compounded, they should yield gases or volatile liquids, which from heating turn into vapor.
3. They must develop in combustion the lowest possible temperature, i.e., have a low temperature of disssociation in order not to damage the barrel (nozzle).
4. They should occupy a small volume, i.e., be as compact as possible.
5. They must be liquid and mix easily; the use of powders is complicated.
6. They can also be gaseous, but have a high critical temperature and low critical pressure, so that it will be easy to use them in a liquified state. Liquified gases, in general, are disadvantageous because of their low temperature, which causes them to absorb heat in order to heat themselves. Also their use is accompanied by losses from evaporation and by the danger of explosion. Also, products that are expensive, chemically unstable, or difficult to obtain, are not suitable' (ref. 23).

It is not difficult to see, that Tsiolkovskiy in this work, formulated important thermodynamic and operational requirements for the fuel of reactive engines. Later, Soviet scientists, continuing to work on the problem of rocket fuel, made great strides in this field.

/619

As people became more and more conscious of the ideas of space flight, Tsiolkovskiy returned with increasing frequency to the question of the meaning behind this extraordinary achievement, what benefits could mankind obtain from the conquest of space.

He wrote about this in "The Investigation of Cosmic Space by Reactive Devices" (1926); the same questions were reflected in his works "The Objectives of Stellar Navigation" (1929), "The Future of Earth and of Mankind," and others.

In the opinion of the scientist, the main goal of space flight was to disseminate humanity throughout space, to establish large settlements, first around the earth and then in the limitless space of the universe, which would in turn, as Tsiolkovskiy pointed out, bring the organization of life and industry under completely new conditions, radically differing from those on earth.

The works of K. E. Tsiolkovskiy played an extremely important role in the development of rocket technology and theory of interplanetary flights, which justifies our regarding him as the founder of this most important field of science and technology.

In the pre-revolutionary years in Russia, several other scientists and inventors, besides Tsiolkovskiy, worked in the field of reactive technology, of which we should give first mention to Fridrikh Arturovich Tsander (1887-1933).

Tsander first became interested in the questions of interplanetary communication very early. Already in his childhood years, he read with enthusiasm science-fiction books on travel to other planets, and he dreamed of flights to the stars.

In 1907-1908, Tsander began scientific research in this field; it is then that he, for the first time, started to think about such questions, related to the construction of spaceships, as "conditions governing the form of the ship...", the place for fuel, processing of solar heat, choice of a driving force," and others (ref. 24). It was then that he made his first estimates concerning the escape of gases from vessels, the work necessary for overcoming the earth's gravity, and several other questions related to the problems of astronautics (see Tsander's autobiography in ref. 25), and in 1909 he first expressed the desirability of using the solid construction material of the rocket as fuel (ref. 26).

In 1909-1910, Tsander made calculations pertinent to the reactive (jet) engine and the work necessary for lifting it to great heights (ref. 27), and from 1917 he began systematic concerted research in the field of interplanetary communication, dedicating his whole life to this problem.

/620

In Tsander's scientific works, three basic trends are observed: the analysis of theoretical questions concerned with astronautics, the formulation of principles for the theory of designing reactive engines, and the solution of practical (applied) questions of rocket technology.

One of the most complex questions encountered by researchers working to solve the problem of interplanetary communication was the problem of a spaceship overcoming the earth's gravitational potential. The calculations have shown that in order to achieve this goal, in the firing of a single rocket the weight of the fuel must comprise 90-98% of the entire starting weight of the spaceship. The construction of such a rocket with the level of technology at that time presented an insurmountable dilemma.

One of the possible methods of overcoming the potential of the earth's gravity was to use multistage rockets, a method which received widespread acclaim in our own time.

The proposed use of multistage rockets at the start had already been encountered in the works of Goddard (1919) and of Obert (1923); in 1929, Tsiolkovskiy worked out their mathematical theory. However, in the beginning of the twenties the question of using multistage rockets had not yet been sufficiently investigated. Tsander, therefore, without rejecting the need for studying all the possible methods of overcoming the forces of the earth's gravity (in several works he mentioned the desirability of investigating "complex rockets, one embedded in another" (ref. 28), i.e., in present-day terminology, multistage rockets), felt at that time that it would be most sensible to use a rocket in conjunction with an airplane.

The essence of this proposal consisted in the following. An interplanetary rocket ship served as the fuselage of a large airplane and, in addition, was supplied with small wings designed for descent. For the flight in lower, denser layers of the atmosphere, either a piston engine of a special construction developed by Tsander, which ran on gasoline or liquid oxygen, or an air-jet engine that used atmospheric oxygen as the oxidant, was to serve as the powerplant.

When, however, high rarefied layers of the atmosphere were reached, liquid ⁶²¹rocket engines were to be turned on, and the parts of the large airplane that became unnecessary, constructed from metals with a high heating capacity, were supposed to be sucked into the main body and melted so that they could be used as additional fuel. For the descent to earth or other planets possessing an atmosphere, the small auxilliary wings were to be used, which would make it possible to descend without using fuel.

Examination of the scientific-biographical materials of Tsander reveals that already by the beginning of the twenties he had developed several novel proposals concerned with the construction of a spaceship, among which were the following:

- 1) To supply the interplanetary ship with wings at the start for flight through the dense layers of the atmosphere.

2) To use the parts of the interplanetary ship that became unnecessary, as additional fuel.

3) To use wings for a gliding descent to earth or to other planets which possess an atmosphere.

The application of all these proposals, according to Tsander, should solve the problem of interplanetary travel in the near future.

Tsander was greatly concerned with finding the most suitable type of fuel for a rocket. Striving to increase the escape speed of the combustion products from the nozzle of reactive engines, he proposed the use of a high-caloric metallic fuel.

As stated above, he expressed this idea for the first time in 1909. Later on, Tsander came back again and again to this idea, continuing to develop and perfect it. It is rather typical of the majority of the projects developed to find that he intended metallic fuel to be used. He also proposed the use of plastics as a supplementary fuel.

Tsander realized, however, that the use of metallic fuel would only slightly increase the exhaust speed of the combustion products, which has a limit (the maximum theoretical exhaust velocity of the combustion products, with the known chemical fuels of today, is not greater than 6750 m/sec). Therefore, he strived to find other types of energy, the utilization of which would enable the problem of interplanetary flights to be solved once and for all.

Tsander also carefully differentiated between the types of engines suitable for the placing of a spaceship into orbit and for carrying out interplanetary (and even interstellar) flights. He wrote: "We thus arrive at the conclusion/622 that rockets, with their enormous fuel expenditures and great thrust, are best suited for the departure from earth's atmosphere and acceleration to the speed of 8 km/sec... Then later, in interplanetary space, with its huge distances and with the possibility of employing low-thrust forces, it is much better to employ the freely available light pressure or to transmit energy over a distance with the aid of very thin mirrors..." (ref. 29).

For flights into interplanetary space, Tsander suggested the use of light pressure considering the following principal variants:

1) Flights with the aid of reflectors, very thin shields, or solenoids directly connected to the spaceship:

2) Flights with the aid of unfolded rotating mirrors that open out in interplanetary space and, by gathering solar rays, direct beams of parallel rays to shields connected to the spaceship,

Tsander, perhaps more than other Russian scientists of that time, paid a great deal of attention to the questions of celestial navigation. It is curious that, even in 1908, he thought about the problem of how many days of flying it

would take to reach Mars and Venus and had posed a theoretical problem for himself, to determine the conditions for moving from one point in space to another with the following requirements: "1) with the least possible work, 2) in the shortest possible time" (ref. 30).

Later on, Tsander had frequent occasion to return to the problem of celestial navigation, continuing to develop and intensify his research. By 1925, he had examined in detail such questions as the movement of a spaceship in the gravitational field of the sun, planets and their satellites, delineating trajectories and the length of flights, as well as the magnitudes of the additional velocities, necessary for their execution (ref. 31).

While working on the problems of interplanetary communication, Tsander did not limit himself to merely posing a question and examining it in a general mode, he further strived to justify his conclusions in detailed, scientifically grounded calculations. Tsander was the first engineer in our country who dedicated himself to solving the problems of astronautics, and this left a certain imprint on his approach to the solution of these problems.

Beginning in the twenties, simultaneously with his development of the problems of interplanetary communication, Tsander paid ever-increasing attention to the second trend of his research work, the development of theoretical principles for the design of reactive engines. In this area, Tsander was a talented theoretician and engineer, who gave an original solution to several very important problems in the planning of design of reactive engines. He wrote the works entitled "Thermal Calculations for a Liquid-Propellant Rocket Engine," "The Utilization of Metal Fuel in Rocket Engines," "Aspects of Rocket Design, Utilizing Metallic Fuel," and others. As stated in an obituary published on 30 March 1933 in the newspaper Tekhnika (Technology), "a number of theoretical works, which provide the only engineering calculations in the world in the reactive field, may be attributed to the pen of Fridrikh Arturovich." /623

Beginning in 1928, Tsander began to bring his concepts in the field of rocket technology to practical fruition. Without abandoning his idea concerning the use of high-caloric metals as auxiliary fuels, he conducted experiments in the preparation of lightweight alloys containing magnesium and their combustion in air.

At approximately the same time, Tsander began to design his first jet engine, the OR-1, with which he proposed testing in practice the analytical methods that he had adopted and to obtain first-hand experimental results.

The OR-1 engine, built in 1929-1930, ran on gasoline and air and developed a thrust of 5 kgm. Careful engineering designs preceded it, by which Tsander solved several practical problems connected with the work of reactive engines.

In the period from 1930 through 1932, Tsander conducted many tests on this engine.

The results obtained from these tests made it possible to go on to the building of more highly perfected engines, in which liquid oxygen was used as

the oxidant. In 1932-1933, with the Group on the Study of Reactive Propulsion (GIRD), Tsander supervised work on the design of liquid rocket engines, to be installed on the rocket plane RP-1 (OR-2 engine) and as a powerplant for the rocket GIRD-X (engine 10).

A premature death denied Tsander the opportunity to bring to conclusion a great deal of what he had thought out and developed. But this was carried on for him by his numerous comrades, students, and followers.

Tsander's works, to a great degree, aided the development of rocket construction in the USSR. "On the basis of these theoretical and practical works," it was stated in the obituary, "F. A. Tsander has formed his own school in the theory and design of reactive engines."

The third Russian researcher to work on the solution of the problems of 624 interplanetary communication was Yuriy Vasil'yevich Kondratyuk, whose life and scientific work have hardly scarcely been examined up to now. Because of this, science historians and biographers still have many questions which will have to be answered. Some details of his biography, for example, are still vague, the beginning date of his work in astronautics has not been precisely determined yet, the chapters written, according to Kondratyuk, in 1921-1926, but not included in his book (apropos, see the Second Author's Preface to ref. 32) have not been found yet, the main stages of his research work are not sufficiently clear.

For a long time, only one of Kondratyuk's works devoted to the problems of astronautics was known, his book, The Conquest of Interplanetary Space, published in 1929 in Novosibirsk. Only rather recently, in the last few years, has it become known that a few other manuscripts by Kondratyuk on the problems of interplanetary communications were preserved and in 1938 were given by the author to the well known aviation historian, and one of the compilers of this collection, B. N. Vorob'yev.⁹

Therefore, the scientific presently known heritage left to us by Kondratyuk, on the questions of interplanetary communication consists of the following materials:

1) A manuscript without a title, consisting of four notebooks bound into one, 104 pages of handwritten text in pencil. When Kondratyuk delivered these materials to Vorob'yev he dated them 1916.

2) A manuscript that begins with the words "To Whomsoever Will Read in Order to Build," 144 pages of text handwritten in ink. This manuscript Kondratyuk dates 1918-1919 on delivery.

⁹Yu. V. Kondratyuk's manuscripts on interplanetary communication are now held in the Institute for the History of Natural Science and Technology of the Academy of Sciences of the USSR.

3) A manuscript without a title, written in ink on 79 sheets of 223 by 357 mm paper. On delivery of his materials to Norob'yev, Kondratyuk first dated it 1920, but then added: "rewritten and revised in 1923-24." One of the copies of this version of the manuscript was sent to V. P. Vetchinkin in 1925 for review.

4) Two copies of typewritten text of "The Conquest of Interplanetary Space," 66 pages with handwritten insertions and notes. Actually, this is a typewritten text of the previous versions with the remarks made by Vetchinkin incorporated (a section was added, entitled "The Combustion Process, Construction of the Combustion Chamber and Exit Tube." The symbols are somewhat changed and the terminology is also partly modified, the derivation of the principal fundamental formula for the flight of a rocket is added). One of these copies was edited in 1927 by Vetchinkin and prepared for publication. /625

5) A book, "The Conquest of Interplanetary Space," published in 1929 in Novosibirsk.

Unfortunately, it was not heretofore possible to determine to what period each of the indicated manuscripts belongs. The problem is greatly complicated by the fact that the dates appearing on them were inserted by Kondratyuk according to the dictates of his memory in 1938, hence, they cannot be acknowledged as absolutely reliable, particularly since in several cases (in the first and third versions) some discrepancies are obvious between the dates given in 1938 by Kondratyuk and those appearing directly or by implication in the text.

By studying Kondratyuk's manuscripts, it is possible to observe how, gradually, in a period of several years, his views were formed on the problems of the conquest of space, how from the first, not always very mature and in some cases rather naive conclusions, Kondratyuk arrived at views which were reflected in his book published in 1929, "The Conquest of Interplanetary Space."

The first version of Kondratyuk's manuscript on interplanetary communication¹⁰ appears as rough notes and cannot be viewed as a finished piece of work.

¹⁰We have not been able to pinpoint the exact date of the beginning of Kondratyuk's research in the field of interplanetary communication. In the Author's Preface to the book Conquest of Interplanetary Space, Kondratyuk pointed out that this work, in its principal parts, was written by him in 1916 (see the present collection p. 57). In 1938, he placed this same date, 1916, on the cover of the first version of the manuscript on interplanetary communication when he delivered his materials to B. N. Vorob'yev. However, in the text of this manuscript Kondratyuk declares that everything written therein he conceived approximately from the day of the change in regimes (i.e., from the end of February) to 25 March 1917. This same date, 1917, Kondratyuk mentions in his letter to N. A. Rynin, wherein he writes: "Having achieved the first positive results in my work in 1917, and not suspecting at that time that I was not the first and only researcher in this field, I rested on my laurels for some time, while awaiting the opportunity to start experimenting..." (ref. 33). Therefore, the question concerning the exact date of the beginning of Kondratyuk's works in this field remains open to conjecture and needs further investigation.

It is more likely that these were preliminary notes in the form of a scientific log, in which the author often makes mistakes, debates with himself, and, in several instances, rewrites and recalculates certain sections. However, already in these early outlines we encounter several interesting statements.

Kondratyuk, like Tsiolkovskiy, first of all, set himself the task of formulating the basic formula for the flight of a rocket, in order to answer the question: "Is it possible at present to make an interplanetary flight on a reactive device with known available substances?" (ref. 34, p. 2). /626

By making the necessary calculations, he was the second to formulate (by a somewhat different method than Tsiolkovskiy) the principal formula for rocket flight (Tsiolkovskiy's formula) and we established that the velocity of a rocket's flight in a vacuum depends only on the characteristics of the fuel and on the initial and final mass.

Arriving at the conclusion that flight to other planets with the aid of a rocket is possible in principal, Kondratyuk set out to render more precise a number of questions concerned with flight into space. In his first manuscript he examined such questions as the influence of gravitational forces and resistance of the medium, the choice of acceleration and the method of departure, the construction of certain parts of the interplanetary spaceship, its control (guidance) and stability, and others.

Here, Kondratyuk mentions the use of solar energy, employing mirrors for the purpose, the development of a reaction from material emissions (α and β particles, cathode rays), the conditions for flights within the limits of the solar system, and the creation of interplanetary bases.

Also worthy of mention is the sequence of initial steps, given by Kondratyuk in this manuscript, toward the conquest of space. He outlined the following stages:

- I. Test the function of the vehicle in the atmosphere.
- II. Flight not too far from the earth's surface, several thousand versts.
- III. Flight to the moon without landing there, actually a flight around the moon.
- IV. A flight to the moon with stopover" (ref. 34, p. 25).

Later on, while continuing to work toward a solution to the problem of interplanetary communication, Kondratyuk finished the second version of the manuscript, which, on delivery of his works to Vorob'yev, he dated 1918-1919.

This version, which was the outgrowth of his previous work, somewhat differed from it by its systematized and detailed manner of presentation. In addition to this, Kondratyuk wrote several new sections: "The Active Agent and its Combustion," "Instrument for Orientation," "Acceleration Indicator," "Utilization of the Relative Motion of Celestial Bodies," and others.

In the early works of Kondratyuk, qualitative relations were given for the most part and not enough detailed mathematical calculations. "I will have frequent occasion," he wrote in the preface to the second version of his manuscript, "to use phrases which are quite inadmissible in scientific writing, such as: 'not too large,' 'sufficiently,' etc., without indicating anything exactly. This is because I do not have on hand the materials for drawing the line between 'sufficient' and 'insufficient,' in fact a good part of the materials needed for the construction of a rocket still have not been assembled" (ref. 35; also present collection, p. 15).

Kondratyuk's manuscripts from this period are characterized by a large number of brilliant and interesting, though technically almost undeveloped ideas. Among them are proposals for discarding the passive mass of a rocket as it becomes unnecessary, the design of nuclear and 'electrorocket' engines, the utilization of solar energy, the creation of interplanetary bases in the form of an artificial satellite of the moon, utilization of the fields of gravity and the relative motion of celestial bodies, and others.

Not all these proposals are original with the author, many of them were expressed before him by other Russian and foreign scientists; Kondratyuk, however, according to his words, did not have an opportunity until 1925 to familiarize himself with the works of other authors on this question, so that he often repeated what had been discovered earlier by others.

In evaluating the importance of Kondratyuk's earlier works for the history of science and technology, it is important also to bear in mind that these manuscripts were not published contemporaneously, and their content was not known before 1925. Therefore, they could not exert an influence on the development of rocket technology and are of interest only for the history of the development of ideas on interplanetary flights.

The third version of the manuscript differed significantly from the first two, in structure as well as in the form of the account.¹¹

In this version, Kondratyuk attempted to give a more detailed mathematical basis to his postulates, striving to present, in his words, "the problem of conquering the solar system not so much in the form of theoretical principles, leaving their development and practical application to the science and technology of the future, as in the form of a plan of attack, which, even if not detailed, is outlined with concrete figures that are fully realizable today with current technology once we have performed experiments not presenting any particular difficulties" (ref. 36, p. 1).

¹¹While delivering his manuscripts to Vorob'yev, Kondratyuk originally dated his version 1920, but later added: "revised and re-edited in 1923-1924." However, the statement that "the author...has only recently had the opportunity to familiarize himself with a portion of the article entitled The Investigation of Cosmic Space by Reactive Devices, published in the journal Vestnik Vozdukhoplavaniya for 1911" proves that this version was finished only in 1925, because Kondratyuk (in his letter to Rynin) ascribes his first acquaintance with Tsiolkovskiy's article to precisely this period (ref. 33).

In the third version, which later became the basis of the book published in 1929, entitled *The Conquest of Interplanetary Space*, Kondratyuk developed many postulates, which in their general features were already evident in the first versions of the manuscript. In addition to this, he wrote several new sections, including the sections relating to metallic and borohydride fuels, proportional passive loads, the action of the atmosphere on a rocket during launching, and others.

At the same time, in the third manuscript version and in the book, some of the materials contained in the first version and, unquestionably deserving consideration, were not developed or even reflected upon. Here, first of all, one should mention the proposal concerning the use of solar energy and the energy of the elemental particles, the creation of 'electrorocket' engines and reflector belts around the earth, the utilization of gravitational fields and relative movements of the heavenly bodies to impart accelerations to the interplanetary spaceship.

Most likely, this is attributable to the fact that Kondratyuk regarded this version as a concept nearing realization and strived to screen out all elements that seemed unrealizable or too far from being brought to fruition. So, for example, in the section devoted to analyzing the types of energy suitable for the execution of rocket flights to other planets, Kondratyuk asserted: "Still another special type of rocket is possible, one which utilizes energy from without, i.e., from the light of the sun. In practice, however, this method of operating a rocket is inapplicable at the present time, or almost inapplicable because of purely technical difficulties... In view of these difficulties, for now we will shelve the idea of a rocket that functions on the energy of solar radiation" (ref. 36, p. 8).

Kondratyuk's book *The Conquest of Interplanetary Space* was the last, most highly developed version of his work devoted to the problem of interplanetary communication.

It should be noted, however, that in the published book, Kondratyuk gave almost all the numerical data in simplified and rounded-off form, striving only to present the physical order of magnitudes with which one would have to deal.

Kondratyuk's works listed above contain several very intriguing ideas, 629 which are of great interest and deserving consideration.

Already in the first version, Kondratyuk hit upon the idea of decreasing the passive mass of a rocket by discarding the parts of its construction no longer needed. He stated: "Everywhere that I speak about the activity of a substance, the weight of this substance should be calculated, taking into account the weight of its container; once we have used up a certain portion of the active substance, we reject the tank in which it was carried. It is better, therefore, and perhaps necessary, not to contain the entire reserve of active substance in one tank but in several progressively smaller ones" (ref. 34, pp. 36-37).

This idea is expressed even more clearly in the second version (ref. 35, pp. 34-36; see also p. 24 of this book), and in the third version Kondratyuk actually approached the idea of multistage rockets, but without giving its construction plan (ref. 36, pp. 16-19). Here, he arrived at the proposal, expressed earlier by Tsander, of using no longer needed structural elements of a rocket as additional fuel (ref. 36, pp. 19-21).

In the same version, Kondratyuk dedicated one special section to various rocket fuels, examining petroleum, acetylene, hydrogen, silicon, as well as metals with a calorific value as fuels, oxygen and ozone as oxidants.

In his works, Kondratyuk paid more attention to such questions as the choice of optimum departure trajectories, the investigation of flight conditions within the solar system, the examination of methods for return to earth with minimum fuel consumption and others.

At first, Kondratyuk examined the conditions of departure without taking into account the forces due to resistance of the medium (drag) and arrived at the conclusion that the method of radially outward departure (vertically upward) is, the most disadvantageous from the energy point of view, since one would have to use the maximum amount of fuel. Here also, however, he showed the most advantageous method of departure under these conditions: Accelerate a body at such an angle that the true acceleration would be perpendicular to the effective direction of the force of gravity and would coincide with the direction of the velocity vector (i.e., on a tangential trajectory). The presence of atmosphere, however, brought important corrections to his estimates, since in departure along a tangential trajectory, the flight would proceed for too long in the appreciably dense atmosphere which would bring to naught all the advantages of 630 the second method. Taking this into account, even in his first version of the manuscript, Kondratyuk stated that first "it is necessary to fly up about 50 versts, in order to escape almost completely the harmful influence of the atmosphere" (ref. 34, p. 20). The same was stated in the second version. Kondratyuk stated that "the main factor here is the first few tens of kilometers of the atmospheric thickness, since beyond this limit its density becomes negligible. Therefore, even the second method of flight must begin approximately as the first, almost perpendicular to the earth's surface, with the acceleration directed along a tangential course from the moment of takeoff" (ref. 35, p. 83).

The problem of flight dynamics was examined much more thoroughly in the third version of the manuscript, where Kondratyuk discussed in detail various types of trajectories of departure, taking into consideration the influence of the resistive forces of the medium on the flight of a rocket, as well as heating of the forward part of the rocket as it passes through dense layers of the atmosphere at high speeds. Here, Kondratyuk advanced the proposal, expressed earlier by Tsander, to supply the rocket with wings for flight through the dense layers of the atmosphere.

In the same work, Kondratyuk examined the various types of trajectories and required speeds, as well as the transfer from one trajectory to another. A little earlier, he mentioned utilizing the earth's speed of rotation about its own axis, as well as its speed of revolution around the sun.

Devoting considerable attention to the problems of space flight theory, Kondratyuk examined several other methods of decreasing the fuel reserves necessary for the execution of interplanetary flights.

"In order not to use up a large quantity of active substance," he wrote in the first version of the manuscript, "the entire vehicle need not land, its velocity need only be reduced so that it move uniformly in a circle as near as possible to the body on which the landing is to be made. Then the inactive part separates from it, carrying the amount of active agent necessary for landing the inactive part and for subsequently rejoining the remainder of the vehicle" (ref. 34, p. 18).

Then he discusses the construction of interplanetary bases with a small gravitational potential. Departing from the majority of researchers, he suggested the creation of such a base in the form of an artificial moon, rather than earth, satellite, so as to protect the base from drag effects due to the residual earth atmosphere.

The suggestion of utilizing the atmosphere as a braking medium in descent/631 is found in all versions of Kondratyuk's manuscript.

"But the atmosphere," he pointed out in the first version of the manuscript, "may turn out to be very useful on the return trip, as an absorber of excess speed, and it would not be necessary to use the active substance for this purpose. The atmosphere will provide two other methods of return besides the normal one. (The nonactive part of the vehicle must be a glider).

"Method I. Direct the vehicle tangentially to the earth, and then near the earth, in its atmosphere, decrease the speed of the vehicle so that in the absence of atmosphere, it would continue to circle uniformly around the earth. But, since it will be in the atmosphere, it will lose speed and finally descend to earth as a glider.

"Method II. On approaching earth, the speed should not be decreased; the vehicle should be directed tangentially and the atmosphere should be used not only for slowing down but also so that the missile will not escape from earth again.

"Both of these methods are difficult and dangerous in that, first of all, the nonactive part of the vehicle must be made in the form of a flying machine capable of maintaining a speed of 5-10 km per sec. in air; secondly, they require very delicate control, since even with a small error the vehicle can again break away from earth, or bury itself in it, or make a turn (very insignificant in ordinary calculations), that would break off its wings and impart such a deceleration that a man sitting inside would be crushed to death. But the great advantage of these methods is that they economize substantially on the use of the active agent (the formulas will be given presently) and, besides, the first method could be rendered automatic and fairly safe" (ref. 34, pp. 20-22).

In the second version, Kondratyuk again focuses considerable attention upon the possible methods of extinguishing speed by atmospheric resistance on the

return trip. Here he also discusses the methods of counteracting heating and suggests making the surfaces from polished, high-melting materials, cooling them, and using laminated surfaces, which are later discarded (see this book p. 37).

It should be noted, as was stated above, the indicated works of Kondratyuk were not published contemporaneously and did not become known until after 1925. In print, the proposal of using the resistance of the medium during descent to earth and other planets possessing atmosphere, was first published by Tsander (ref. 37).

In the third version, and in his book, Kondratyuk devoted a special chap-632ter to the extinction of speed during descent by the resistance of the atmosphere (ref. 32; present collection, pp. 100-107), asserting further, that this method, in conjunction with interplanetary bases, is the key to the actual conquest of space (ref. 32). As a result of his research, Kondratyuk arrived at the conclusion that the realization of interplanetary travel can take place in the not too distant future. He expressed his ideas concerning the expected implications for mankind from the conquest of space and said that "it is the possibility of beginning in the immediate future to improve the economy of our planet that should be regarded as the chief aspect of tremendous importance to us in mastering the outer space of the solar system" (see the Second Author's Preface to ref. 32; present collection, p. 59).

A survey of the works of I. V. Meshcherskiy, K. E. Tsiolkovskiy, F. A. Tsander, and Yu. V. Kondratyuk reveals that already by the mid-twenties of the present century, our own scientists had laid the foundation for the mechanics of variable-mass bodies and the theory of space flight, having advanced several proposals of considerable consequence. Among such proposals were the following:

- 1) The use of liquid-propellant rocket engines.
- 2) The use of high-caloric metallic fuel.
- 3) The use of new types of energy (atomic and 'electrorocket' engines, the pressure of solar light).
- 4) The creation of intermediate interplanetary bases in the form of artificial satellites around earth or other celestial bodies.
- 5) The use of multiunit and multistage rockets.
- 6) The use of rocket construction materials as additional fuel.
- 7) The use of wings or airfoils for a gliding descent to earth and other planets possessing atmosphere.

These proposals testify to the high level attained by Soviet astronomical theoreticians justifying the claim that by the end of the twenties the principles of interplanetary communication had been developed in the USSR.

However, while occupying the forefront in the theory of rocket technology, Soviet scientists for rather a long period of time (the years of the civil war and foreign intervention, the beginning of the restoration period) were denied adequate material and technological opportunities for the realization of their ideas. It should be noted that almost every representative of our first generation of scientists, the pioneers of rocket technology (with the exception of 633 F. A. Tsander), satisfied themselves with stating their proposals in the field of rocket technology, without embarking upon their practical realization.

But already by the end of the twenties, together with the achievements made in the industrialization of the country and the development of scientific experimentation in the field of reaction (jet and rocket) engines, the premises for the practical solution of building long-range rockets had been established in the USSR. Whereas, prior to this time, Soviet scientists working in the field of rocket technology had been, for the most part, known for their theoretical works, starting with the thirties and forties, the Soviet school of rocket construction achieved important successes also in the practical realization of reaction-powered flights. The talented scientists and engineers who stepped up to take the place of our first generation of native scientists, the pioneers of rocket technology, realized and developed the bold ideas of their predecessors. In our own time, great advances have been made in the Soviet Union in mastering outer space. Collective groups of Soviet scientists, engineers, and workers have created artificial earth satellites, space rockets, and spaceships, the launching of which has opened up a new era, the era of man's conquest of the universe.

REFERENCES

1. Tretskiy, I. I. On Methods of Controlling Aerostats (O sposobakh upravlyat' aerostatami) (never published). Tiflis, 1849. Preserved in the Central State Archives of Military History (TsGVIA), Folio 1, Catalog 1, Document 17474, sheets 35-140.
2. Journal of the Artillery Division, Military Science Committee (Zhurnal Artilleriy-skogo otdeleniya Voyenno-uchenogo komiteta), 31 December 1851, TsGVIA, Folio 1, Catalog 1, Document 17474, sheets 153-157.
3. Sokovnin, N. The Airship (Vozdushnyy korabl'). St. Petersburg, 1866, p. 35.
4. Konstantinov, K. I. Aeronautics (Vozdukhoplavaniye). Morskoy Sbornik, No. 8, Part III, pp. 99-101, 1856.
5. Scientific Archives of the N. E. Zhukovskiy Museum, No. 1079, sheet 66.
6. Scientific Archives of the N. E. Zhukovskiy Museum, No. 1079, sheet 82.
7. Scientific Archives of the N. E. Zhukovskiy Museum, No. 2990/1, p. 131.
8. Scientific Archives of the N. E. Zhukovskiy Museum, No. 2990/1, p. 135.
9. Scientific Archives of the N. E. Zhukovskiy Museum, No. 2990/2, sheet 1.

10. Records of the Imperial Russian Technical Society and Summary of Patents Issued through the Department of Commerce and Manufacturing (Zapiski Imperatorskogo Russkogo Tekhnicheskogo Obshchestva i Svod privilegiy, vydavayemykh po departamentu trgovli i manufaktur), No. 3. St. Petersburg, 1883.
11. Scientific Archives of the N. E. Zhukovskiy Museum, No. 2990/1, p. 145.
12. Scientific Archives of the N. E. Zhukovskiy Museum, No. 2990/3, p. 221.
13. Geshvend, F. General Principle of the Design of an Aeronautical Steamship (Steamplane) (Obshcheye osnovaniye ustroystva vozdukhoplavatel'nogo parokhoda (parolet)). Kiev, 1887.
14. Geshvend, F. Supplement (to the brochure published in April 1887) on Simplifying the Design of an Aeronautical Steamship (Steamplane). Kiev, 1887.
15. Journal of the Meeting of the M. M. Boreskov Commission (Zhurnal Zasedaniya komissii M. M. Boreskova), 16 March 1888, TsGVIA, Folio 808, Catalog 1, Document 26, sheets 14-17.
16. Fedorov, A. P. A New Principle of Aeronautics Excluding the Atmosphere as a Supportive Medium (Novyy printsip vozdukhoplavaniya, isklyuchayushchiy atmosferu kak opornuyu sredu). St. Petersburg, 1896.
17. Tsiolkovskiy, K. E. Investigation of Cosmic Space by Reactive Devices (Issledovaniye mirovykh prostranstv reaktivnymi priborami). Kaluga, 1926, p. 2.
18. Meshcherskiy, I. V. Dynamics of a Variable-Mass Point (Dinamika tochki peremennoy massy). St. Petersburg, 1897.
19. Meshcherskiy, I. V. Equation of Motion of a Variable-Mass Point in the General Case (Urvneniye dvizheniya tochki peremennoy massy v obshchem sluchaye). Izvestiya Peterburgskogo Politekhnicheskogo Instituta, Vol. 1, Nos. 1-2, p. 77, 1904.
20. Tsiolkovskiy, K. E. Investigation of Cosmic Space by Reactive Devices (Issledovaniye mirovykh prostranstv reaktivnymi priborami). Vestnik Vozdukhoplavaniya, No. 9, 1912.
21. Tsiolkovskiy, K. E. Investigation of Cosmic Space by Reactive Devices. Vestnik Vozdukhoplavaniya, No. 2, p. 6, 1912.
22. Archives of the Academy of Sciences of the USSR, Folio 555, Catalog 1, Document 105.
23. Tsiolkovskiy, K. E. Reaching the Stratosphere (Dostizheniye stratosfery). Archives of the Academy of Sciences of the USSR, Folio 555, Catalog 1, Document 73, sheet 7.

24. Zander, F. Problems Relating to the Construction of a Spaceship (Fragen zum Bau eines Weltschiffes). Written in a notebook preserved in the family archives of the scientist.
25. Rynin, N. A. Rockets and Jet Engines (Rakety i dvigateli pryamoy reaktsii). Leningrad, 1929, p. 190.
26. Tsander, F. A. The Problem of Flight by Means of Reaction Machines (Problema poleta pri pomoshchi reaktivnykh apparatov). Moscow, 1932, p. 71.
27. Tsander, F. Voyages to Other Planets and to the Moon (Polety na drugiye planety i na Lunu). Page 5. Manuscript preserved in the family archives of the scientist.
28. An organizational report by Engineer F. A. Tsander on proposed projects of the scientific research section of the Society for the Study of Interplanetary Communications (Obshchestvo izucheniya mezhplanetnykh soobshcheniy), delivered 15 July 1924. In the book: F. A. Tsander. The Problem of Flight by Means of Reactive Machines; Interplanetary Voyages (Problema poleta pri pomoshchi reaktivnykh apparatov. Mezhplanetnyye polety). Edited by L. K. Korneyev. Oborongiz (State Publishing House of the Defense Industry), Moscow, 1961. p. 444.
29. Tsander, F. A. Voyages to Other Planets (Polety na drugiye planety) (second article).
30. Zander, F. The Spaceships (Ether-Ships) by which Intercommunication between the Stars will be made Possible (Die Weltschiffe (Ätherschiffe), die den Verkehr zwischen den Sternen ermöglichen sollen). Travel in Outer Space (Die Bewegung im Weltenraum). Page 7-8. Manuscript preserved in the family archives of the scientist.
31. Tsander, F. A. Voyages to Other Planets (Theory of Interplanetary Travel) (Perelety na drugiye planety (Teoriya mezhplanetnykh puteshestviy)).
32. Kondratyuk, Yu. V. Conquest of Interplanetary Space (Zavoyevaniye mezhplanetnykh prostranstv). Present edition, p. 59.
33. Rynin, N. A. Theory of Space Flight (Teoriya kosmicheskogo poleta). Leningrad, 1932, p. 345.
34. Kondratyuk, Yu. Manuscript (first version).
35. Kondratyuk, Yu. Manuscript (second version). Present edition, pp. 15-48.
36. Kondratyuk, Yu. Manuscript (third version).
37. Tsander, F. A. Voyages to Other Planets (Perelety na drugiye planety). Tekhnika i Zhizn', No. 13, pp. 15-16, 1924.

BIBLIOGRAPHY OF THE PUBLISHED WORKS OF N. I. KIBAL'CHICH,
K. E. TSIOLKOVSKIY, F. A. TSANDER, AND YU, V. KONDRATYUK
ON THE PROBLEMS OF REACTIVE FLYING MACHINES
AND INTERPLANETARY TRAVEL

634

Compiled by B. N. Vorob'yev

N. I. Kibal'chich

1. Concept for an Aeronautical Machine (Proyekt vozdukhoplavatel'nogo pribora). Byloye, No. 10-11, pp. 115-121, 1918.
2. N. I. Kibal'chich's Concept for an Aeronautical Machine, in an article by A. Shiukov: Member of the "Will of the People" Party, N. I. Kibal'chich, and his Concept for a Reactive Flying Machine (Narodovolets N. I. Kibal'chich i yego proyekt reaktivnogo letatel'nogo apparata) (on the 48th anniversary of the death of N. I. Kibal'chich). Vestnik Vozdukhonogo Flota, No. 4, pp. 39-41, 1929.
3. Writings of N. I. Kibal'chich on his Proposed Reactive Flying Machine (Zapiska N. I. Kibal'chicha o predlozhenom im reaktivnom letatel'nom pribore). Aeronautics and Aviation in Russian before 1907 (Vozdukhoplavaniye i aviatsiya v Rossii do 1907). Collected documents and materials, edited by V. A. Popov. Oborongiz, Moscow, 1956, pp. 236-240.
4. The Affair of 1 March 1881 (Delo 1-go marta 1881 g.). Governmental Report. St. Petersburg, 1906, pp. 328-329.
5. Central State Archives of the October Revolution (TsGAOR), F. D. P., Third Official Correspondence, 1881, Document 79, Part I.

K. E. Tsiolkovskiy

1. How to Protect Fragile and Delicate Objects from Jolts and Shocks (Kak predokhranit' khrupkiye i nezhnyye veshchi ot tolchkov i udarov). Transactions of the Physical Sciences Division of the Society of Amateur Scientists (Trudy otdeleniya fizicheskikh nauk Obshchestva lyubiteley yestestvoznaniya), Moscow, Vol. 4, No. 2, pp. 17-18, 1891.
2. On the Moon; a Fantastic Tale (Na Lune. Fantasticheskaya povest'). Izd. Sytina (Sytin Publishing House), Moscow, 1893. 48 pages, 4 illustrations.
3. Speculations about Earth and Sky and the Effects of Universal Gravitation (Grezy o Zemle i nebe i efekty vselednogo tyagoteniya). Izd. A. N. Goncharova (A. N. Goncharova, publisher), Moscow, 1895. 143 pages, no illustrations.

4. Will Earth Ever be Able to Communicate the Existence Thereon of Intelligent Beings to the Inhabitants of Other Planets? (Mozhet li kogda-nibud' Zemlya zayavit' zhitelyam drugikh planet o sushchestvovanii na ney razumnykh sushchestv?). Kaluzhskiy Vestnik (newspaper), No. 68, 26 November 1896.
5. The Investigation of Cosmic Space by Reactive Devices (Issledovaniye mirovykh prostranstv reaktivnymi priborami). Nauchnoye Obozreniye (St. Petersburg), No. 5, pp. 45-75, 1903.
6. The Reactive Device as a Means of Flight in Empty Space and in the Atmosphere (Reaktivnyy pribor, kak sredstvo poleta v pustote i atmosfere). Vozdukhoplavatel', No. 2, pp. 110-113, 1910.
7. The Investigation of Cosmic Space by Reactive Devices. Vestnik Vozdukhoplavaniya, Nos. 19-22, 1911; Nos. 2, 3, 5-7, 9, 1912.
8. Without Gravity; a Science-Fantasy Discussion (Bez tyazhesti. Nauchno-fantasticheskiy rasskaz). Priroda i Lyudi, No. 36, pp. 577-579, 1914.
9. The Investigation of Cosmic Space by Reactive Devices (supplement to parts I and II of the work by the same name). Published by the author, Kaluga, 1914. 16 pages, 1 illustration.
10. Beyond Earth (Vne Zemli) (a narrative). Published by: Kaluzhskogo Obshchestva Izucheniya Prirody i Mestnogo Kraya (Kaluga Society for the Study of Nature and Locale), Kaluga, 1920. 118 pages.
11. The Rocket in Outer Space (Raketa v kosmicheskoye prostranstvo). Second edition. Kaluga, 1924. 32 pages, 1 illustration.
12. Letter to the Editor (Pis'mo v redaktsiyu). Svyaz', No. 18, p. 14, 1925. Portrait of the author included.
13. The Investigation of Cosmic Space by Reactive Devices (republication of the papers of 1903 and 1911 with certain alterations and additions). Kaluga, 1926. 127 pages, 3 illustrations.
14. The Space Rocket; Experimental Preparation (Kosmicheskaya raketa. Opytnaya 635 podgotovka). Kaluga, 1927. 24 pages, 1 illustration.
15. Space Rocket Journeys (with a Biography of K. E. Tsiolkovskiy by S. V. Bessonov); the Reactive Engine (Kosmicheskiye raketnyye poyezda. (S biografiyey K. E. Tsiolkovskogo S. V. Bessonova). Reaktivnyy dvigatel'). Published by the staff of: Sektsii Nauchnykh Rabotnikov (Scientific Workers' Section), Kaluga, 1929. 38 pages, frontispiece portrait of Tsiolkovskiy.
16. On the Moon; a Fantastic Tale. Preface by Ya. I. Perel'man. Gosizdat (State Publishing House), Moscow-Leningrad, 1929. 75 pages, 8 illustrations.

17. A New Airplane; Beyond Earth's Atmosphere; the Reactive Engine (Novyy aeroplan. Za atmosferoy Zemli. Reaktivnyy dvigatel'). Kaluga, 1929. 38 pages, 4 illustrations.
18. The Objectives of Celestial Navigation (Tseli zvezdoplavaniya). Kaluga, 1929. 40 pages.
19. Celestial Navigation (Zvezdoplavaniya). Kaluga, 1930. 32 pages.
20. The Reactive Airplane (Reaktivnyy aeroplan). Published by the author, Kaluga, 1930. 24 pages.
21. On the Moon; a Fantastic Tale (Na Misyatsi. Fantastichna povist'). Preface by Ya. I. Perel'man. Kharkov, 1930. 48 pages, 7 illustrations.
22. Introductory essay by K. E. Tsiolkovskiy to the third chapter: The Rockets of K. E. Tsiolkovskiy and the Concept for Flight in Them (Rakety K. E. Tsiolkovskogo i proyekt poleta na nikh). In: Rynin, N. A. K. E. Tsiolkovskiy, His Life, Work, and Rockets (K. E. Tsiolkovskiy, yego zhizn', raboty i rakety). Leningrad, 1931. pp. 32-34.
23. From Airplane to Astroplane (Ot samoleta k zvezdoletu). Iskry nauki, No. 2, pp. 55-57, 1931.
24. The Reactive Engine and its Achievements (Reaktivnoye dvizheniye i yego uspekhi). Samolet, No. 6, p. 17, 1932.
25. Density of Various Layers of the Atmosphere (Plotnost' raznykh sloyev atmosfery). Samolet, Nos. 8-9, pp. 36-37, 1932.
26. Theory of Reactive Motion (Teoriya reaktivnogo dvizheniya). V Boy za Tekhniku, Nos. 15-16, pp. 19-21, 1932. 3 illustrations.
27. A Semireactive Stratoplane (Polureaktivnyy stratoplan). Khochu vse znat' No. 29, pp. 6-7, 1932. Zhurgazob'yedineniye (Newspaper and Periodical Association). 4 illustrations and portrait of the author.
28. Flight into the Stratosphere (Polet v stratosferu). Grazhdanskaya aviatsiya, No. 19, pp. 20-22, 1932. 4 illustrations and portrait of the author.
29. Flight into the Stratosphere. Tekhnika (newspaper), No. 87, 18 September 1932. 4 illustrations.
30. My Dirigible and Stratoplane (Moy dirizhabl' i stratoplan). Krasnaya Zvezda (newspaper), No. 242, 18 October 1932.
31. Spacecraft (Zvezdolet). Znaniye-Sila, Nos. 23-24, p. 15, 1932. 1 illustration.
32. The Semireactive Stratoplane (Stratoplan polureaktivnyy). Kaluga, 1932. 32 pages, 4 illustrations.

33. The Dirigible, Stratoplane, and Spacecraft as Three Stages in the Supreme Achievements of the USSR (Dirizhabl', stratoplan i zvezdolet kak tri stupeni velichayshikh dostizheniy SSSR). Grazhdanskaya Aviatsiya, Nos. 9, 11, 12, 1933. 10 illustrations.
34. On the Moon (Na Lune) (Annotation and Afterword by Ya. I. Perel'man). Gosaviavtoizdat (State Publishing House of the Aviation and Automotive Industries), Moscow-Leningrad, 1933. 40 pages, 6 illustrations.
35. Gravity has Disappeared; a Fantasy (Tyazhest' izchesla. Fantasticheskiy ocherk). Gosmashmetizdat (State Scientific and Technical Publishing House for Machinery and Metalworking Literature), Moscow-Leningrad, 1933. 119 pages, 21 illustrations.
36. Beyond the Atmosphere (Za atmosferu). Vokrug Sveta, No. 1, pp. 10-24, 1934. 2 illustrations and portrait of the author.
37. Grandiose Conceptions (Grandioznyye zamysly). Kino (newspaper), No. 8, 18 February 1934.
38. The Principle of Reactive Motion (Printsip reaktivnogo dvizheniya). V Boy za Tekhniku, No. 6, p. 25, 1934.
39. Selected Works of K. E. Tsiolkovskiy (Izbrannyye trudy K. E. Tsiolkovskogo) (with a biographical sketch by Prof. N. D. Monseyev). Book II: Reactive Motion (Reaktivnoye dvizheniye). Edited by Engineer F. A. Tsander. Gosmashmetizdat, Leningrad, 1934. 216 pages.
40. On the Moon (Annotation and Afterword by Ya. I. Perel'man). Second edition. Gosmashmetizdat, Moscow-Leningrad, 1934 (issued 1935). 38 pages, 6 illustrations.
41. Gravity has Disappeared; a Fantasy. Second edition. Gosmashmetizdat, Moscow-Leningrad, 1934. 111 pages, 21 illustrations.
42. Rocket Devices in the Exploration of the Stratosphere (Raketnyye pribory v issledovanii stratosfery). Rabochaya Moskva (newspaper), No. 51, 3 March 1935.
43. Is it Only Fantasy? (Tol'ko li fantaziya?). Komsomol'skaya Pravda (newspaper), No. 168, 23 July 1935.
44. Flight in the Future (Polet v budushcheye). Kommuna (newspaper - Kaluga), No. 184, 18 August 1935. Portrait of the author included.
45. From Airplane to Astroplane. Pishchevaya Industriya (newspaper), No. 127, 636 2 September 1935.
46. Are Extra-Atmospheric Flights Mere Fantasy? (Fantaziya li zaatmosfernyye polety?). Komsomol'skaya Pravda (newspaper), No. 216, 18 September 1935. 1 illustration and portrait of the author.

47. On the Moon - Speculations about the Earth and the Heavens (Na Lune - Grezy o zemle i nebe) (fantastic narrative and essay). Editing and biographical sketch by Ya. I. Perel'man. ONTI (Association of Scientific and Technical Publishing Houses), Moscow-Leningrad, 1935. Editorial Board of Popular-Scientific and Juvenile Literature. 132 pages.
48. Energy of Chemical Compounding of Substances and the Selection of Explosive Components for the Rocket Engine (Energiya khimicheskogo soyedineniya veshchestv i vybor sostavnykh chastey vzryva dlya raketnogo dvigatelya). Collected articles: Rocket Technology (Raketnaya tekhnika). Edited by I. T. Kleyenov, G. E. Langemak, M. K. Tikhonravov, S. P. Korolev, and Yu. A. Pobedonostsev. Moscow-Leningrad, 1936, No. 1, pp. 42-49.
49. Works on the Space Rocket (Trudy o kosmicheskoy rakete). Collection: Reactive Motion (Reaktivnoye dvizheniye). Edited by P. S. Dubenskiy, I. A. Merkulov, M. K. Tikhonravov, V. S. Zuyev, and A. F. Nistratov. Moscow-Leningrad, 1936, No. 2, pp. 7-12.
50. Fuel for the Rocket (Toplivo dlya rakety). Collection: Reactive Motion. Edited by P. S. Dubenskiy, I. A. Merkulov, M. K. Tikhonravov, V. S. Zuyev, and A. F. Nistratov. Moscow-Leningrad, 1936, No. 2, pp. 12-20.
51. Speculations about Earth and Sky (On the Moon, fantastic narrative and essay). Edited with biographical sketch by Ya. I. Perel'man. Second edition. GONTI (State United Scientific and Technical Publishing House), Moscow-Leningrad, 1938. Editorial Board of Popular Scientific and Juvenile Literature. 120 pages.
52. Works in Rocket Technology (Trudy po raketnoy tekhnike). Edited (with introductory article) by M. K. Tikhonravov. Oborongiz (State Publishing House of the Defense Industry), Moscow, 1947. 368 pages.
53. Collected Works (Sobraniye sochineniy). Second Volume. Reactive Flying Machines (Reaktivnyye letatel'nyye apparaty). Izd. AN SSSR (Publishing House of the Academy of Sciences of the USSR), Moscow, 1954. 453 pages.
54. On the Moon; a Fantastic Tale. Detgiz (State Publishing House for Children's Literature), Moscow, 1955. 64 pages.
55. On the Moon; a Fantastic Tale for Children. Illustrated by N. I. Grishin. Izd. "Sovetskaya Rossiya" ("Soviet Russia" Publishing House), Moscow, 1957. 48 pages.
56. On the Moon; a Fantastic Tale. Afterword by A. Kostin: From Dream to Reality (Iz mechty v deystvitel'nost'). Illustrated by A. Kaurov. Znamya (newspaper - Kaluga), 1957. 64 pages.
57. Beyond Earth. A science-fiction story. Foreword by Academician A. A. Blagonravov. Illustrated by N. I. Grishin. Izd "Sovetskaya Rossiya," Moscow, 1958. 154 pages.

58. Beyond Earth. A science-fiction story. Edited with Foreword by B. N. Vorob'yev. Second edition, with corrections. Izd. AN SSSR, Moscow, 1958. 144 pages.
59. Speculations about Earth and Sky - In the West (Grezy o zemle i nebe - Na Veste). A science-fantasy work. Edited with Foreword by B. N. Vorob'yev. Izd. AN SSSR, Moscow, 1959. 96 pages.
60. Road to the Stars (Put' k zvezdam). Collection of science-fantasy works. Foreword by Academician V. G. Fesenkov. Editor-compiler and author of Afterword B. N. Vorob'yev. Izd. AN SSSR, Moscow, 1960. 352 pages.
61. Reactive Flying Machines (Reaktivnyye letatel'nyye apparaty). Editor-compilers B. N. Vorob'yev and V. N. Sokol'skiy. Editor-in-Chief A. A. Kosmodem'yanskiy. Izd. "Nauka" ("Science" Publishing House), Moscow, 1964. 473 pages.

F. A. Tsander

1. Voyages to Other Planets (Perelety na drugiye planety). Tekhnika i Zhizn', No. 13, pp. 15-16, 1924.
2. Reactive Engines (Reaktivnyye dvigateli). Samolet, No. 1, pp. 31-32, 1932.
3. The Problem of Flight by Means of Reactive Machines (Problema poleta pri pomoshchi reaktivnykh apparatov). Gosaviavtoizdat (State Publishing House of the Aviation and Automotive Industries), Moscow, 1932. 75 pages, 36 illustrations.
4. Thermal Calculations for a Liquid-Propellant Rocket Engine (Teplovoy raschet raketnogo dvigatelya na zhidkom toplive). Collected articles: Rocket Technology (Raketnaya tekhnika). Edited by I. T. Kleymenov, G. E. Langemak, M. K. Tikhonravov, S. P. Korolev, and Yu. A. Pobedonostsev. Moscow-Leningrad, 1936, No. 1, pp. 97-120.
5. The Utilization of Metallic Fuel in Rocket Engines (Primeneniye metallicheskogo topliva v raketnykh dvigatelyakh). Collection: Rocket Technology. Moscow-Leningrad, 1936, No. 1, pp. 121-135.
6. Thermal Calculations for a Liquid-Propellant Rocket Engine (second article). Collection: Rocket Technology. Moscow-Leningrad, 1937, No. 5, pp. 77-90. 637
7. Aspects of Rocket Design, Utilizing Metallic Fuel (Voprosy konstruirovaniya rakety, ispol'zuyushchey metallicheskoye toplivo). Collection: Rocket Technology. Moscow-Leningrad, 1937, No. 5, pp. 91-110.
8. Comparison of Fuel Consumption for the Case when Oxygen is Taken from the Atmosphere and for the Case when it is Stored on the Rocket (Sravneniye raskhoda topliva dlya sluchaya, kogda kislorod beretsya iz atmosfery, i dlya sluchaya, kogda on zapasen v rakete). Collection: Rocket Technology. Moscow-Leningrad, 1937, No. 5, pp. 111-115.

9. The Problem of Flight by Means of Reactive Machines. Collected articles. Edited by M. K. Tikhonravov. Oborongiz (State Publishing House of the Defense Industry), Moscow, 1947. 240 pages.
10. The Problem of Flight by Means of Reactive Machines; Interplanetary Voyages (Problema poleta pri pomoshchi reaktivnykh apparatov. Mezhplanetnyye polety). Collected articles. Edited (with Foreword) by L. K. Korneyev. Second supplementary edition. Oborongiz, Moscow, 1961. 459 pages.

Yu. V. Kondratyuk

1. To Whomsoever Will Read in Order to Build (Tem, kto budet chitat', chtoby stroit'). Manuscript of article preserved in the Institute for the History of Natural Science and Technology, Academy of Sciences of the USSR. Autographed (1918-1919). 144 pages. Printed for the first time in the present collection (see pages 15-48).
2. Conquest of Interplanetary Space (Zavoyevaniye mezhplanetnykh prostranstv). Edited with Foreword by Prof. V. P. Vetchinkin. Novosibirsk, 1929. 72 pages. Graphs and illustrations appended on six sheets.
3. Conquest of Interplanetary Space. Edited by P. I. Ivanov. Oborongiz (State Publishing House of the Defense Industry), Moscow, 1947. 82 pages, 7 illustrations.

Translated for NASA by Stemar Engineering Inc.
4940 Long Beach Blvd., Long Beach, California